

PRODUCT INFORMATION PACKET

Model No: 365TSTFS6501
Catalog No: E612
75 HP Severe Duty Motor, 3 phase, 3600 RPM, 460 V, 365TS Frame, TEFC
Severe Duty Motors



Regal and Marathon are trademarks of Regal Rexnord Corporation or one of its affiliated companies.
©2021 Regal Rexnord Corporation, All Rights Reserved. MC017097E

Nameplate Specifications

Output HP	75 Hp	Output KW	56.0 kW
Frequency	60 Hz	Voltage	460 V
Current	84.0 A	Speed	3555 rpm
Service Factor	1.15	Phase	3
Efficiency	94.5 %	Power Factor	88.5
Duty	Continuous	Insulation Class	F
Design Code	B	KVA Code	G
Frame	365TS	Enclosure	Totally Enclosed Fan Cooled
Thermal Protection	No	Ambient Temperature	40 °C
Drive End Bearing Size	6312	Opp Drive End Bearing Size	6312
UL	Recognized	CSA	Y
CE	Y	IP Code	54
Number of Speeds	1		

Technical Specifications

Electrical Type	Squirrel Cage Inverter Rated	Starting Method	Line Or Inverter
Poles	2	Rotation	Reversible
Resistance Main	.07 Ohms	Mounting	Rigid Base
Motor Orientation	Horizontal	Drive End Bearing	Ball
Opp Drive End Bearing	Ball	Frame Material	Cast Iron
Shaft Type	TS	Overall Length	30.28 in
Frame Length	14.50 in	Shaft Diameter	1.875 in
Shaft Extension	4 in	Assembly/Box Mounting	F1/F2 Capable
Connection Drawing	A-EE7300U	Outline Drawing	B-SS508654-1450

This is an uncontrolled document once printed or downloaded and is subject to change without notice. Date Created:10/12/2021

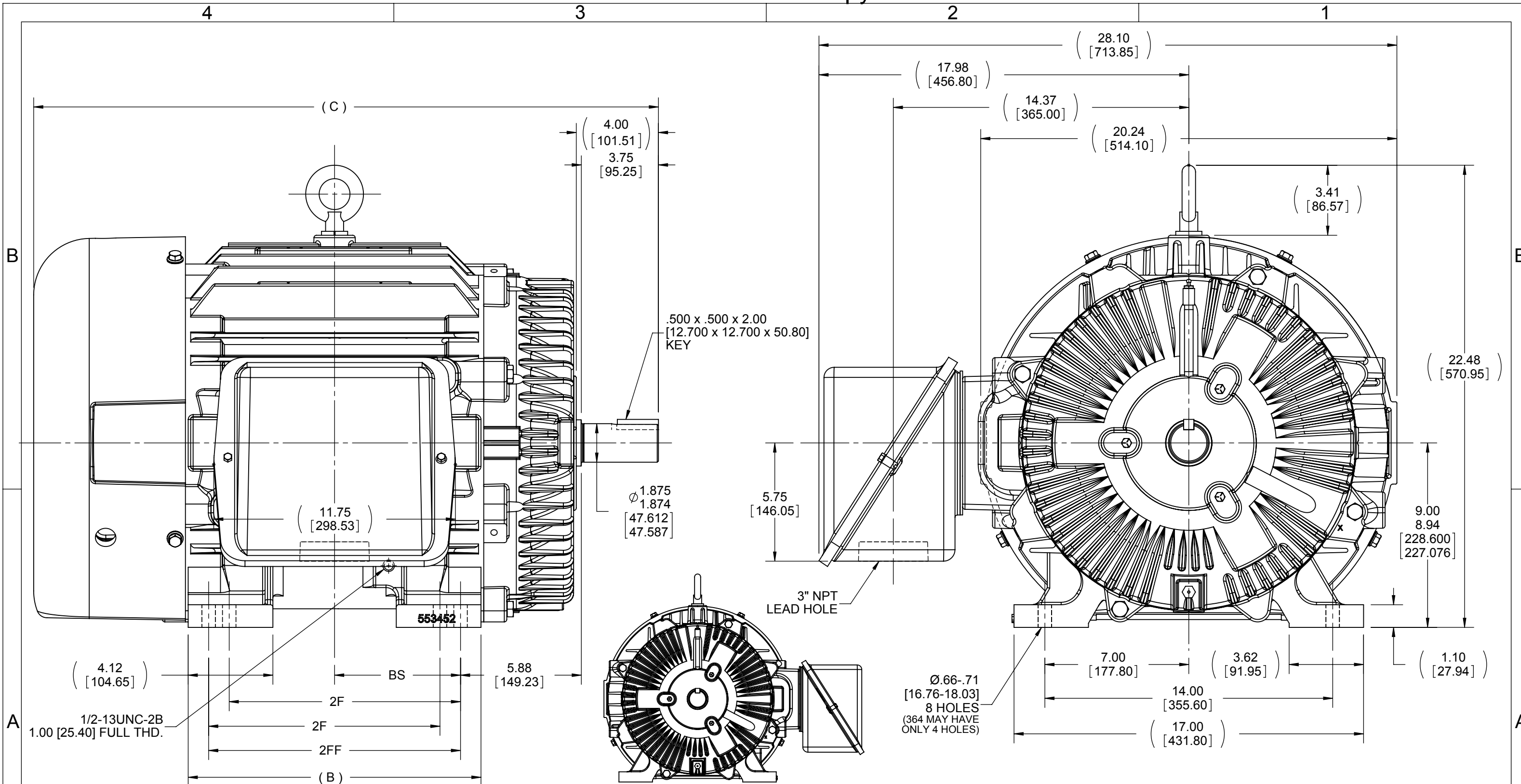

- NOTES:
 1. CONDUIT BOX CAN BE ROTATED IN 90° STEPS.
 2. CONDUIT BOX CAN BE MOUNTED ON OPPOSITE SIDE BY REMOVING BRACKETS AND TURNING FRAME 180°.
 3. NAMEPLATES TO BE READ FROM CONDUIT BOX SIDE OF MOTOR.

DASH	FRAME	B	C	2F	2FF	BS
1350	364TS	13.25 [336.55]	29.38 [746.25]	11.25 [285.75]	---	5.62 [142.75]
1450	364/365TS	14.25 [361.95]	30.28 [769.11]	11.25 [285.75]	12.25 [311.15]	6.12 [155.45]

DRAWING REVISION C	REVISION BY JJB	DATE 03-27-2014
ECO ECO-0048229	APPROVED BY JHA	DATE 03-26-2014
ECO DESCRIPTION UPDATED TO CURRENT STANDARDS		
<small>COPYRIGHT REGAL BELOIT AMERICA, INC. ALL RIGHTS RESERVED PROPRIETARY AND CONFIDENTIAL INFORMATION - THIS DOCUMENT IS THE PROPERTY OF REGAL BELOIT AMERICA, INC. ("OWNER") AND CONTAINS OWNER'S PROPRIETARY INFORMATION. ANY PERSON, CORPORATION OR OTHER FIRM RECEIVING IT IS DEEMED, BY RECEIVING IT, TO AGREE THAT IT, AND/OR ANY PART OF IT, SHALL NOT BE DISCLOSED TO ANY PERSON, CORPORATION OR OTHER ENTITY, DUPLICATED, AND/OR USED, EXCEPT AS EXPRESSLY APPROVED IN WRITING IN ADVANCE BY OWNER. THIS DOCUMENT SHALL BE RETURNED TO OWNER UPON REQUEST. IT MAY BE SUBJECT TO CERTAIN RESTRICTIONS UNDER APPLICABLE EXPORT CONTROL LAWS AND REGULATIONS.</small>		

TOLERANCES UNLESS OTHERWISE SPECIFIED:

DEC.	INCH	mm	ANGLE
.X	±0.1	[±2.5]	±0.5°
.XX	±0.03	[±0.76]	
.XXX	±0.005	[±0.127]	
.XXXX	±0.0005	[±0.0127]	

REMOVE BURRS & BREAK SHARP
 EDGES: .003/.015 [0.076/.381]
 CORNER FILLETS: .02 [0.51]
 MACHINED SURFACES: 125 INCH 3.2 mm
 mm SHOWN IN [BRACKETS]

DRAWN BY TLB	DATE 05-03-1988
APPROVED BY ML	DATE 06-03-1988
PROCESS/FINISH	
THIRD ANGLE PROJECTION	

Regal Beloit America, Inc.	
DESCRIPTION OUTLINE 360TS FR-TEFC-TAPPED LEAD HOLE	
MATERIAL	
SIZE B	DRAWING NUMBER SS508654
SHEET 1 OF 1	

IF MOTOR HAS 9 LEADS



IF MOTOR HAS 6 LEADS



A-9806 DECAL IF CALLED FOR

IF MOTOR HAS 12 LEADS



VIEW OF TERMINAL END

DRAWING REVISION L	REVISION BY AJW	DATE 05-04-2015	TOLERANCES UNLESS OTHERWISE SPECIFIED:	DRAWN BY DRS	Regal Beloit America, Inc.																					
ECO ECO-0077067	APPROVED BY EWH	DATE 05-05-2015	<table style="font-size: small; border-collapse: collapse;"> <tr> <td><u>DEC.</u></td> <td><u>INCH</u></td> <td><u>mm</u></td> <td><u>ANGLE</u></td> </tr> <tr> <td>.X</td> <td>±0.1</td> <td>[±2.5]</td> <td>±7' 30"</td> </tr> <tr> <td>.XX</td> <td>±0.02</td> <td>[±0.51]</td> <td></td> </tr> <tr> <td>.XXX</td> <td>±0.005</td> <td>[±0.127]</td> <td></td> </tr> <tr> <td>.XXXX</td> <td>±0.0005</td> <td>[±0.0127]</td> <td></td> </tr> </table>	<u>DEC.</u>			<u>INCH</u>	<u>mm</u>	<u>ANGLE</u>	.X	±0.1	[±2.5]	±7' 30"	.XX	±0.02	[±0.51]		.XXX	±0.005	[±0.127]		.XXXX	±0.0005	[±0.0127]		DATE 09-27-1996
<u>DEC.</u>	<u>INCH</u>	<u>mm</u>	<u>ANGLE</u>																							
.X	±0.1	[±2.5]	±7' 30"																							
.XX	±0.02	[±0.51]																								
.XXX	±0.005	[±0.127]																								
.XXXX	±0.0005	[±0.0127]																								
ECO DESCRIPTION UPDATED TO SOLIDWORKS			REMOVE BURRS & BREAK SHARP EDGES: .003/.015 [.076/.381] X 45° CORNER FILLETS: R.02 [.51] MACHINED SURFACES: 200 INCH √ 5.1 mm √	APPROVED BY GK	MATERIAL	PROCESS/FINISH																				
COPYRIGHT REGAL BELOIT AMERICA, INC. ALL RIGHTS RESERVED. PROPRIETARY AND CONFIDENTIAL INFORMATION - THIS DOCUMENT IS THE PROPERTY OF REGAL BELOIT AMERICA, INC. ("OWNER") AND CONTAINS OWNER'S PROPRIETARY INFORMATION. ANY PERSON, CORPORATION OR OTHER FIRM RECEIVING IT IS DEEMED, BY RECEIVING IT, TO AGREE THAT IT, AND/OR ANY PART OF IT, SHALL NOT BE DISCLOSED TO ANY PERSON, CORPORATION OR OTHER ENTITY, DUPLICATED, AND/OR USED, EXCEPT AS EXPRESSLY APPROVED IN WRITING IN ADVANCE BY OWNER. THIS DOCUMENT SHALL BE RETURNED TO OWNER UPON REQUEST. IT MAY BE SUBJECT TO CERTAIN RESTRICTIONS UNDER APPLICABLE EXPORT CONTROL LAWS AND REGULATIONS.			mm SHOWN IN [BRACKETS]	DATE 09-30-1996	SIZE A	DRAWING NUMBER EE7300U	SHEET 1 OF 1																			
			THIRD ANGLE PROJECTION	REFERENCE																						

Data Sheet

Date: 6/19/2017

Customer: _____

Attention: _____

Submitted by: FAREEDA DUDEKULA



365TSTFS6501

Submittal

Data @ 460 V

Motor Load Data

Load	0%	25%	50%	75%	100%	115%	125%	LR
Current (Amps)	22.5	30.0	46.0	64.0	84.0	96.0	106	542
Torque (ft-lb)	0.00	27.5	55.0	83.0	111	128	140	180
RPM	3600	3590	3580	3565	3555	3,545	3540	0
Efficiency (%)		92.4	94.5	94.5	94.5	94.1	93.6	
P.F. (%)	6.0	63.0	81.0	86.5	88.5	89.0	89.0	31.5

Motor Speed Data

	LR	Pull-Up	BD	Rated	Idle
Speed (RPM)	0	1800	3350	3555	3600
Current (Amps)	542	488	335	84.0	22.5
Torque (ft-lb)	180	162	320	111	0.00

Information Block				
HP	75.0			
Sync. RPM	3600			
Frame	365			
Enclosure	TEFC			
Construction	TFS			
Voltage	460 V			
Frequency	60 Hz			
Design	A			
LR Code letter	G			
Service Factor	1.15			
Temp Rise @ FL	80 °C			
Duty	CONT			
Ambient	40 °C			
Elevation	1,000 feet			
Rotor/Shaft wk ²	8.2 Lb-Ft ²			
Ref Wdg	T365262 NONE			
Sound Pressure @ 1M	75 dBA			
VFD Rating	CONSTANT 2:1			
Outline Dwg	B-SS508654-1450			
Conn. Diag	A-EE7300U			
Additional Specifications:				
0				
0				
EQUIV CKT (OHMS / PHASE)				
R1	R2	X1	X2	Xm
0.0550	0.0410	0.3190	0.2800	11.3780

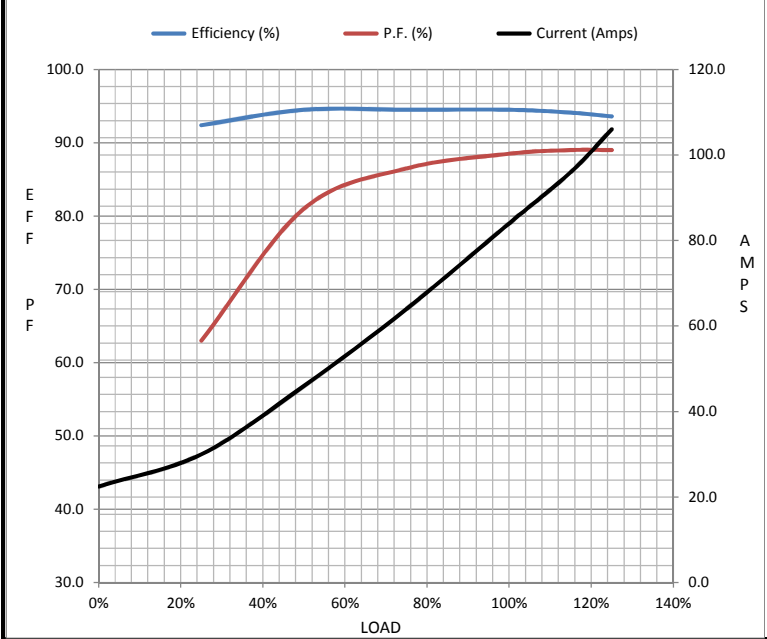

Speed -Torque Curve

