

PRODUCT INFORMATION PACKET

Model No: 365TSHFS9026

Catalog No: W593

75 HP Severe Duty Motor, 3 phase, 1800 RPM, 460 V, 365TS Frame, TEFC
Severe Duty Motors



Regal and Marathon are trademarks of Regal Rexnord Corporation or one of its affiliated companies.
©2021 Regal Rexnord Corporation, All Rights Reserved. MC017097E



Nameplate Specifications

Output HP	75 Hp	Output KW	56.0 kW
Frequency	60 Hz	Voltage	460 V
Current	86.0 A	Speed	1775 rpm
Service Factor	1.15	Phase	3
Efficiency	95 %	Power Factor	85
Duty	Continuous	Insulation Class	F
Design Code	B	KVA Code	G
Frame	365TS	Enclosure	Totally Enclosed Fan Cooled
Thermal Protection	No	Ambient Temperature	40 °C
Drive End Bearing Size	6312	Opp Drive End Bearing Size	6312
UL	Recognized	CSA	Y
CE	Y	IP Code	56
Number of Speeds	1		

Technical Specifications

Electrical Type	Squirrel Cage Inverter Rated	Starting Method	Line Or Inverter
Poles	4	Rotation	Reversible
Resistance Main	.08 Ohms	Mounting	Rigid Base
Motor Orientation	Horizontal	Drive End Bearing	Ball
Opp Drive End Bearing	Ball	Frame Material	Cast Iron
Shaft Type	TS	Overall Length	30.28 in
Frame Length	14.50 in	Shaft Diameter	1.875 in
Shaft Extension	4 in	Assembly/Box Mounting	F1/F2 CAPABLE
Connection Drawing	A-EE7300	Outline Drawing	B-SS508654-1450

This is an uncontrolled document once printed or downloaded and is subject to change without notice. Date Created:10/12/2021

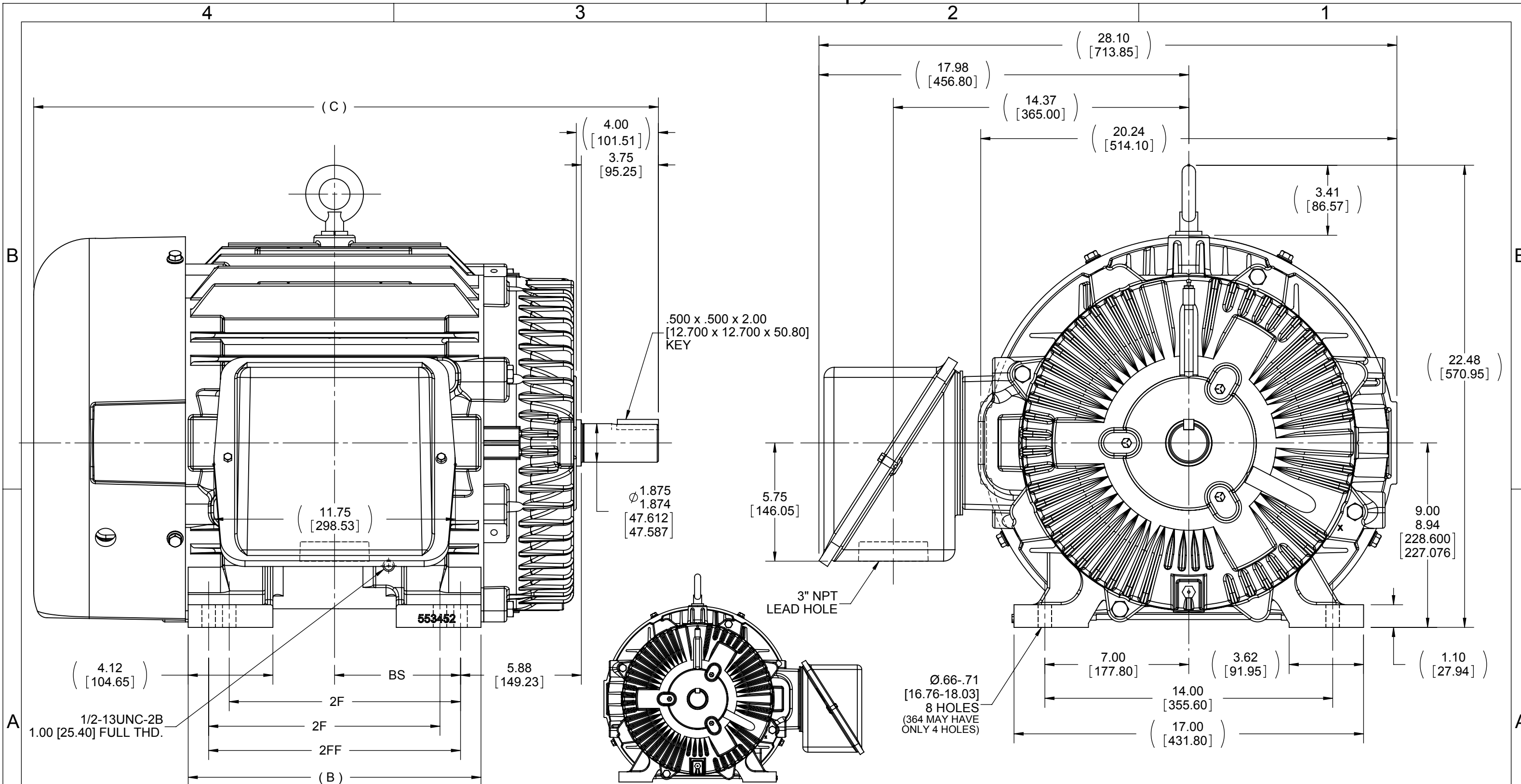

- NOTES:
 1. CONDUIT BOX CAN BE ROTATED IN 90° STEPS.
 2. CONDUIT BOX CAN BE MOUNTED ON OPPOSITE SIDE BY REMOVING BRACKETS AND TURNING FRAME 180°.
 3. NAMEPLATES TO BE READ FROM CONDUIT BOX SIDE OF MOTOR.

DASH	FRAME	B	C	2F	2FF	BS
1350	364TS	13.25 [336.55]	29.38 [746.25]	11.25 [285.75]	---	5.62 [142.75]
1450	364/365TS	14.25 [361.95]	30.28 [769.11]	11.25 [285.75]	12.25 [311.15]	6.12 [155.45]

DRAWING REVISION C	REVISION BY JJB	DATE 03-27-2014
ECO ECO-0048229	APPROVED BY JHA	DATE 03-26-2014
ECO DESCRIPTION UPDATED TO CURRENT STANDARDS		
<small>COPYRIGHT REGAL BELOIT AMERICA, INC. ALL RIGHTS RESERVED PROPRIETARY AND CONFIDENTIAL INFORMATION - THIS DOCUMENT IS THE PROPERTY OF REGAL BELOIT AMERICA, INC. ("OWNER") AND CONTAINS OWNER'S PROPRIETARY INFORMATION. ANY PERSON, CORPORATION OR OTHER FIRM RECEIVING IT IS DEEMED, BY RECEIVING IT, TO AGREE THAT IT, AND/OR ANY PART OF IT, SHALL NOT BE DISCLOSED TO ANY PERSON, CORPORATION OR OTHER ENTITY, DUPLICATED, AND/OR USED, EXCEPT AS EXPRESSLY APPROVED IN WRITING IN ADVANCE BY OWNER. THIS DOCUMENT SHALL BE RETURNED TO OWNER UPON REQUEST. IT MAY BE SUBJECT TO CERTAIN RESTRICTIONS UNDER APPLICABLE EXPORT CONTROL LAWS AND REGULATIONS.</small>		

TOLERANCES UNLESS OTHERWISE SPECIFIED:

DEC.	INCH	mm	ANGLE
.X	±0.1	[±2.5]	±0.5°
.XX	±0.03	[±0.76]	
.XXX	±0.005	[±0.127]	
.XXXX	±0.0005	[±0.0127]	

REMOVE BURRS & BREAK SHARP
 EDGES: .003/.015 [0.076/.381]
 CORNER FILLETS: .02 [0.51]
 MACHINED SURFACES: 125 INCH 3.2 mm

DRAWN BY TLB	DATE 05-03-1988
APPROVED BY ML	DATE 06-03-1988
PROCESS/FINISH	
THIRD ANGLE PROJECTION	

REGAL™ Regal Beloit America, Inc.

DESCRIPTION
360TS FR-TEFC-TAPPED LEAD HOLE

MATERIAL

SIZE **B** DRAWING NUMBER **SS508654** SHEET **1 OF 1**

**THREE PHASE - SINGLE VOLTAGE
MOTOR - CONDUIT BOX @ 'A'**

**TO REVERSE ROTATION:
INTERCHANGE ANY TWO
LINE LEAD CONNECTIONS.**

TERMINAL BLOCK WHEN SPECIFIED

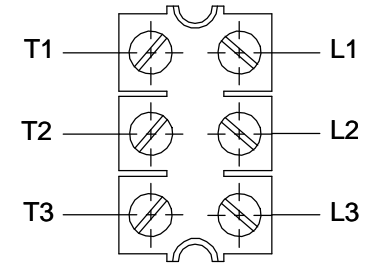

VIEW OF TERMINAL END

**IF MOTOR HAS
6 LEADS**



A-9806 DECAL

**OPTIONAL CORD
CONNECTION**



DRAWING REVISION AB	REVISION BY JJB	DATE 06-27-2017
ECO ECO-0125361	APPROVED BY TB	DATE 06-27-2017
ECO DESCRIPTION UPDATED TO CURRENT STANDARDS		
<small>COPYRIGHT REGAL BELOIT AMERICA, INC. ALL RIGHTS RESERVED. PROPRIETARY AND CONFIDENTIAL INFORMATION - THIS DOCUMENT IS THE PROPERTY OF REGAL BELOIT AMERICA, INC. ("OWNER") AND CONTAINS OWNER'S PROPRIETARY INFORMATION. ANY PERSON, CORPORATION OR OTHER FIRM RECEIVING IT IS DEEMED, BY RECEIVING IT, TO AGREE THAT IT, AND/OR ANY PART OF IT, SHALL NOT BE DISCLOSED TO ANY PERSON, CORPORATION OR OTHER ENTITY, DUPLICATED, AND/OR USED, EXCEPT AS EXPRESSLY APPROVED IN WRITING IN ADVANCE BY OWNER. THIS DOCUMENT SHALL BE RETURNED TO OWNER UPON REQUEST. IT MAY BE SUBJECT TO CERTAIN RESTRICTIONS UNDER APPLICABLE EXPORT CONTROL LAWS AND REGULATIONS.</small>		



DRAWN BY DA
DATE 03-26-1993
APPROVED BY TB
DATE 03-26-1993
REFERENCE
THIRD ANGLE PROJECTION

Regal Beloit America, Inc.	
DESCRIPTION CONNECTION DIAGRAM EXTERNAL - SINGLE VOLTAGE - 3Ø MOTOR	
MATERIAL	PROCESS/FINISH
SIZE A	DRAWING NUMBER EE7300
SHEET 1 OF 1	