

# PRODUCT INFORMATION PACKET

Model No: 365TSHFS19002

Catalog No: W592

Severe Duty Motors, TEFC, 75 HP, 3 Ph, 60 Hz, 575 V, 3555 RPM, 365TS Frame



Regal and are trademarks of Regal Rexnord Corporation or one of its affiliated companies.  
©2022 Regal Rexnord Corporation, All Rights Reserved. MC017097E

**Nameplate Specifications**

Output HP	<b>75 Hp</b>	Output KW	<b>56.0 kW</b>
Frequency	<b>60 Hz</b>	Voltage	<b>575 V</b>
Current	<b>67.0 A</b>	Speed	<b>3555 rpm</b>
Service Factor	<b>1.15</b>	Phase	<b>3</b>
Efficiency	<b>94.5 %</b>	Power Factor	<b>88.5</b>
Duty	<b>Continuous</b>	Insulation Class	<b>F</b>
Design Code	<b>B</b>	KVA Code	<b>G</b>
Frame	<b>365TS</b>	Enclosure	<b>Totally Enclosed Fan Cooled</b>
Thermal Protection	<b>No Protection</b>	Ambient Temperature	<b>40 °C</b>
Drive End Bearing Size	<b>6312</b>	Opp Drive End Bearing Size	<b>6312</b>
UL	<b>Recognized</b>	CSA	<b>Y</b>
CE	<b>Y</b>	IP Code	<b>56</b>
Number of Speeds	<b>1</b>		

**Technical Specifications**

Electrical Type	<b>Squirrel Cage Inverter Rated</b>	Starting Method	<b>Line Or Inverter</b>
Poles	<b>2</b>	Rotation	<b>Reversible</b>
Resistance Main	<b>.07 Ohms</b>	Mounting	<b>Rigid Base</b>
Motor Orientation	<b>Horizontal</b>	Drive End Bearing	<b>Ball</b>
Opp Drive End Bearing	<b>Ball</b>	Frame Material	<b>Cast Iron</b>
Shaft Type	<b>TS</b>	Overall Length	<b>30.28 in</b>
Frame Length	<b>14.50 in</b>	Shaft Diameter	<b>1.875 in</b>
Shaft Extension	<b>4 in</b>	Assembly/Box Mounting	<b>F1/F2 Capable</b>
Inverter Load	<b>CONSTANT 2:1</b>		
Connection Drawing	<b>A-EE7300U</b>	Outline Drawing	<b>B-SS508654-1450</b>

This is an uncontrolled document once printed or downloaded and is subject to change without notice. Date Created:05/11/2022



**IF MOTOR HAS 9 LEADS**

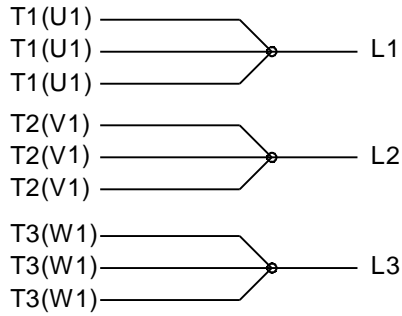

**IF MOTOR HAS 6 LEADS**

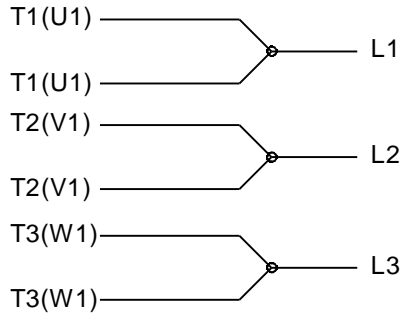

A-9806 DECAL IF CALLED FOR

**IF MOTOR HAS 12 LEADS**

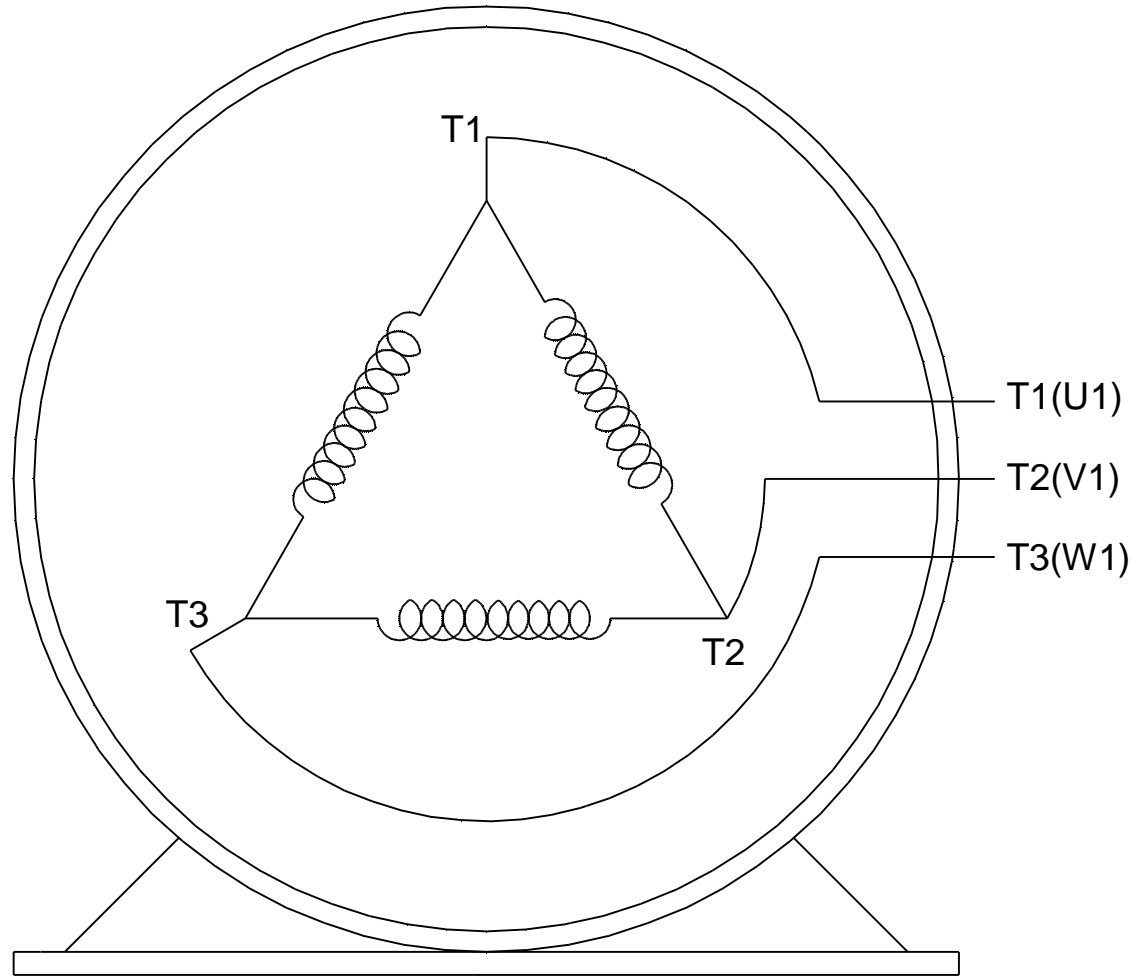
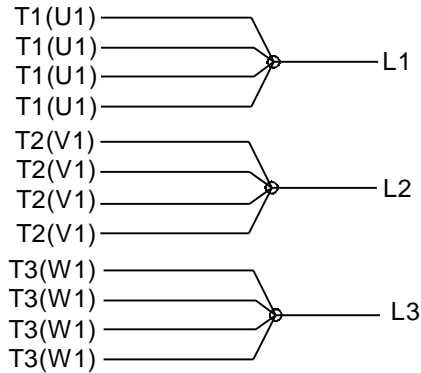

**VIEW OF TERMINAL END**

DRAWING REVISION <b>L</b>	REVISION BY <b>AJW</b>	DATE <b>05-04-2015</b>	TOLERANCES UNLESS OTHERWISE SPECIFIED:	DRAWN BY <b>DRS</b>	<b>Regal Beloit America, Inc.</b>																			
ECO <b>ECO-0077067</b>	APPROVED BY <b>EWH</b>	DATE <b>05-05-2015</b>	<table style="font-size: small; border-collapse: collapse;"> <tr> <td><u>DEC.</u></td> <td><u>INCH</u></td> <td><u>mm</u></td> <td><u>ANGLE</u></td> </tr> <tr> <td>.X</td> <td>±0.1</td> <td>[±2.5]</td> <td>±7' 30"</td> </tr> <tr> <td>.XX</td> <td>±0.02</td> <td>[±0.51]</td> <td></td> </tr> <tr> <td>.XXX</td> <td>±0.005</td> <td>[±0.127]</td> <td></td> </tr> <tr> <td>.XXXX</td> <td>±0.0005</td> <td>[±0.0127]</td> <td></td> </tr> </table>	<u>DEC.</u>		<u>INCH</u>	<u>mm</u>	<u>ANGLE</u>	.X	±0.1	[±2.5]	±7' 30"	.XX	±0.02	[±0.51]		.XXX	±0.005	[±0.127]		.XXXX	±0.0005	[±0.0127]	
<u>DEC.</u>	<u>INCH</u>	<u>mm</u>	<u>ANGLE</u>																					
.X	±0.1	[±2.5]	±7' 30"																					
.XX	±0.02	[±0.51]																						
.XXX	±0.005	[±0.127]																						
.XXXX	±0.0005	[±0.0127]																						
ECO DESCRIPTION <b>UPDATED TO SOLIDWORKS</b>			REMOVE BURRS & BREAK SHARP EDGES: .003/.015 [.076/.381] X 45° CORNER FILLETS: R.02 [.51] MACHINED SURFACES: 200 $\sqrt{\text{INCH}}$ 5.1 $\sqrt{\text{mm}}$ mm SHOWN IN [BRACKETS]	APPROVED BY <b>GK</b>	<b>CONN DIAGRAM-EXTERNAL</b> 3Ø SINDLE VOLTAGE																			
COPYRIGHT REGAL BELOIT AMERICA, INC. ALL RIGHTS RESERVED. PROPRIETARY AND CONFIDENTIAL INFORMATION - THIS DOCUMENT IS THE PROPERTY OF REGAL BELOIT AMERICA, INC. ("OWNER") AND CONTAINS OWNER'S PROPRIETARY INFORMATION. ANY PERSON, CORPORATION OR OTHER FIRM RECEIVING IT IS DEEMED, BY RECEIVING IT, TO AGREE THAT IT, AND/OR ANY PART OF IT, SHALL NOT BE DISCLOSED TO ANY PERSON, CORPORATION OR OTHER ENTITY, DUPLICATED, AND/OR USED, EXCEPT AS EXPRESSLY APPROVED IN WRITING IN ADVANCE BY OWNER. THIS DOCUMENT SHALL BE RETURNED TO OWNER UPON REQUEST. IT MAY BE SUBJECT TO CERTAIN RESTRICTIONS UNDER APPLICABLE EXPORT CONTROL LAWS AND REGULATIONS.				DATE <b>09-30-1996</b>		MATERIAL	PROCESS/FINISH																	
				REFERENCE	SIZE <b>A</b>	DRAWING NUMBER <b>EE7300U</b>	SHEET <b>1 OF 1</b>																	