

PRODUCT INFORMATION PACKET

Model No: 365THFS19086

Catalog No: W582A

50 HP, Severe Duty Motors, 3 phase, 1200 RPM, 460 V, 365T Frame, TEFC
Severe Duty Motors



Regal and Marathon are trademarks of Regal Rexnord Corporation or one of its affiliated companies.
©2021 Regal Rexnord Corporation, All Rights Reserved. MC017097E



Nameplate Specifications

Output HP	50 Hp	Output KW	37.0 kW
Frequency	60 Hz	Voltage	460 V
Current	61.5 A	Speed	1182 rpm
Service Factor	1.15	Phase	3
Efficiency	94.5 %	Power Factor	80.5
Duty	Continuous	Insulation Class	F
Design Code	B	KVA Code	G
Frame	365T	Enclosure	Totally Enclosed Fan Cooled
Thermal Protection	No	Ambient Temperature	40 °C
Drive End Bearing Size	6314	Opp Drive End Bearing Size	6312
UL	Recognized	CSA	Y
CE	Y	IP Code	56
Hazardous Location	DIVISION 2 T2B	Number of Speeds	1

Technical Specifications

Electrical Type	Squirrel Cage Inverter Rated	Starting Method	Line Or Inverter
Poles	6	Rotation	Reversible
Resistance Main	.12 Ohms	Mounting	Rigid Base
Motor Orientation	Horizontal	Drive End Bearing	Ball
Opp Drive End Bearing	Ball	Frame Material	Cast Iron
Shaft Type	T	Overall Length	32.51 in
Frame Length	14.50 in	Shaft Diameter	2.375 in
Shaft Extension	6.12 in	Assembly/Box Mounting	F1/F2 CAPABLE
Connection Drawing	A-EE7300U	Outline Drawing	B-SS508590-1450

This is an uncontrolled document once printed or downloaded and is subject to change without notice. Date Created:11/30/2021

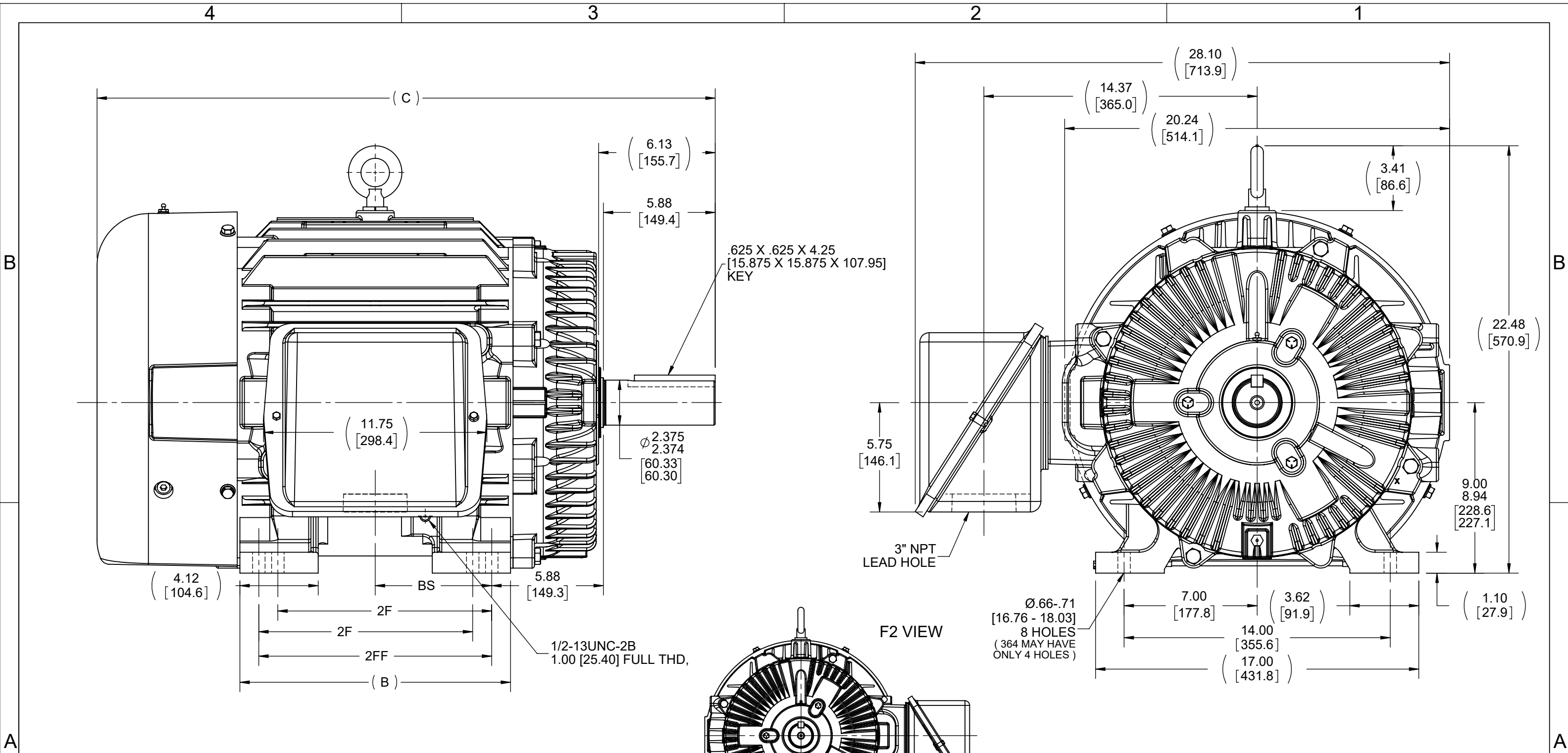

.625 X .625 X 4.25
[15.875 X 15.875 X 107.95]
KEY

Ø 2.375
2.374
[60.33
60.30]

1/2-13UNC-2B
1.00 [25.40] FULL THD,

3" NPT
LEAD HOLE

F2 VIEW

Ø.66-.71
[16.76 - 18.03]
8 HOLES
(364 MAY HAVE
ONLY 4 HOLES)

- NOTES:
 1. CONDUIT BOX CAN BE ROTATED IN 90° STEPS.
 2. CONDUIT BOX CAN BE MOUNTED ON OPPOSITE SIDE BY REMOVING BRACKETS AND TURNING FRAME 180°.
 3. NAMEPLATES TO BE READ FROM CONDUIT BOX SIDE OF MOTOR.
 4. DIMENSION IN [] DESIGNATE MILLIMETERS.

DASH	FRAME	B	C	2F	2FF	BS
1350	364T	13.25 [336.55]	31.51 [800.35]	11.25 [285.75]	---	5.62 [142.74]
1450	364/365T	14.25 [361.95]	32.51 [825.75]	11.25 [285.75]	12.25 [311.15]	6.12 [155.44]

DRAWING REVISION H	REVISION BY VS	REV DATE/© DATE 09-27-2021
REQUEST NUMBER NMR-0210511	APPROVED BY VS	DATE 09-27-2021
REQUEST NUMBER DESCRIPTION VIEWS UPDATED		
<small>COPYRIGHT (PER REVISION DATE) REGAL BELOIT AMERICA, INC. ALL RIGHTS RESERVED. PROPRIETARY AND CONFIDENTIAL INFORMATION - THIS DOCUMENT IS THE PROPERTY OF REGAL BELOIT AMERICA, INC. ("OWNER") AND CONTAINS OWNER'S PROPRIETARY INFORMATION. ANY PERSON, CORPORATION OR OTHER FIRM RECEIVING IT IS DEEMED, BY RECEIVING IT, TO AGREE THAT IT, AND/OR ANY PART OF IT, SHALL NOT BE DISCLOSED TO ANY PERSON, CORPORATION OR OTHER ENTITY, DUPLICATED, AND/OR USED, EXCEPT AS EXPRESSLY APPROVED IN WRITING IN ADVANCE BY OWNER. THIS DOCUMENT SHALL BE RETURNED TO OWNER UPON REQUEST. IT MAY BE SUBJECT TO CERTAIN RESTRICTIONS UNDER APPLICABLE EXPORT CONTROL LAWS AND REGULATIONS.</small>		

TOLERANCES (EXCEPT AS NOTED):
 DEC. INCH mm ANGLE
 .X ±0.1 [±3] ±7° 30"
 .XX ±0.03 [±0.8]
 .XXX ±0.005 [±0.13]
 .XXXX ±0.0005 [±0.013]
 REMOVE BURRS & BREAK SHARP EDGES: .003/.015 [08/.38] X 45°
 CORNER FILLETS: R.02 [5]
 MACHINED SURFACES: 200 INCH/mm 5.1
 mm DIMENSIONS IN [BRACKETS] ARE FOR REFERENCE ONLY

DRAWN BY TLB
DATE 01-29-1988
APPROVED BY ML
DATE 01-29-1988
REFERENCE
THIRD ANGLE PROJECTION

REGAL Regal Beloit America, Inc.	
DESCRIPTION OUTLINE	
360T FR. - TEFC - GROUND LUG - TAPPED LEAD HOLE	
MATERIAL	PROCESS/FINISH
SIZE B	DRAWING NUMBER SS508590
SHEET 1 OF 1	

IF MOTOR HAS 9 LEADS



IF MOTOR HAS 6 LEADS



A-9806 DECAL IF CALLED FOR

IF MOTOR HAS 12 LEADS



VIEW OF TERMINAL END

DRAWING REVISION L	REVISION BY AJW	DATE 05-04-2015	TOLERANCES UNLESS OTHERWISE SPECIFIED:	DRAWN BY DRS	Regal Beloit America, Inc.																					
ECO ECO-0077067	APPROVED BY EWH	DATE 05-05-2015	<table style="font-size: small; border-collapse: collapse;"> <tr> <td><u>DEC.</u></td> <td><u>INCH</u></td> <td><u>mm</u></td> <td><u>ANGLE</u></td> </tr> <tr> <td>.X</td> <td>±0.1</td> <td>[±2.5]</td> <td>±7' 30"</td> </tr> <tr> <td>.XX</td> <td>±0.02</td> <td>[±0.51]</td> <td></td> </tr> <tr> <td>.XXX</td> <td>±0.005</td> <td>[±0.127]</td> <td></td> </tr> <tr> <td>.XXXX</td> <td>±0.0005</td> <td>[±0.0127]</td> <td></td> </tr> </table>	<u>DEC.</u>			<u>INCH</u>	<u>mm</u>	<u>ANGLE</u>	.X	±0.1	[±2.5]	±7' 30"	.XX	±0.02	[±0.51]		.XXX	±0.005	[±0.127]		.XXXX	±0.0005	[±0.0127]		DATE 09-27-1996
<u>DEC.</u>	<u>INCH</u>	<u>mm</u>	<u>ANGLE</u>																							
.X	±0.1	[±2.5]	±7' 30"																							
.XX	±0.02	[±0.51]																								
.XXX	±0.005	[±0.127]																								
.XXXX	±0.0005	[±0.0127]																								
ECO DESCRIPTION UPDATED TO SOLIDWORKS			APPROVED BY GK	DATE 09-30-1996	MATERIAL	PROCESS/FINISH																				
COPYRIGHT REGAL BELOIT AMERICA, INC. ALL RIGHTS RESERVED. PROPRIETARY AND CONFIDENTIAL INFORMATION - THIS DOCUMENT IS THE PROPERTY OF REGAL BELOIT AMERICA, INC. ("OWNER") AND CONTAINS OWNER'S PROPRIETARY INFORMATION. ANY PERSON, CORPORATION OR OTHER FIRM RECEIVING IT IS DEEMED, BY RECEIVING IT, TO AGREE THAT IT, AND/OR ANY PART OF IT, SHALL NOT BE DISCLOSED TO ANY PERSON, CORPORATION OR OTHER ENTITY, DUPLICATED, AND/OR USED, EXCEPT AS EXPRESSLY APPROVED IN WRITING IN ADVANCE BY OWNER. THIS DOCUMENT SHALL BE RETURNED TO OWNER UPON REQUEST. IT MAY BE SUBJECT TO CERTAIN RESTRICTIONS UNDER APPLICABLE EXPORT CONTROL LAWS AND REGULATIONS.			REMOVE BURRS & BREAK SHARP EDGES: .003/.015 [.076/.381] X 45° CORNER FILLETS: R.02 [.51] MACHINED SURFACES: 200 $\sqrt{\text{INCH}}$ 5.1 $\sqrt{\text{mm}}$ mm SHOWN IN [BRACKETS]	REFERENCE	SIZE A	DRAWING NUMBER EE7300U	SHEET 1 OF 1																			
				THIRD ANGLE PROJECTION																						

CERTIFICATION DATA SHEET

Model#: 365THFS19086 AN **WINDING#:** T367601 NONE 3
CONN. DIAGRAM: A-EE7300U **ASSEMBLY:** F1/F2 CAPABLE
OUTLINE: B-SS508590-1450

TYPICAL MOTOR PERFORMANCE DATA

HP	KW	SYNC. RPM	F.L. RPM	FRAME	ENCLOSURE	KVA CODE	DESIGN
50	37	1200	1182	365T	TEFC	G	B

PH	Hz	VOLTS	FL AMPS	START TYPE	DUTY	INSL	S.F	AMB°C	ELEVATION
3	60	460	61.5	LINE OR INVERTER	CONTINUOUS	F3	1.15	40	3300

FULL LOAD EFF: 94.5	3/4 LOAD EFF: 94.5	1/2 LOAD EFF: 94.1	GTD. EFF	ELEC. TYPE	NO LOAD AMPS
FULL LOAD PF: 80.5	3/4 LOAD PF: 76	1/2 LOAD PF: 66	93.6	SQ CAGE INV RATED	25

F.L. TORQUE	LOCKED ROTOR AMPS	L.R. TORQUE	B.D. TORQUE	F.L. RISE°C
222 LB-FT	362	445 LB-FT 200	625 LB-FT 282	70

SOUND PRESSURE @ 3 FT.	SOUND POWER	ROTOR WK^2	MAX. WK^2	SAFE STALL TIME	STARTS /HOUR	APPROX. MOTOR WGT
58 dBA	68 dBA	17.2 LB-FT^2	- LB-FT^2	25 SEC.	-	1025 LBS.

***** SUPPLEMENTAL INFORMATION *****

DE BRACKET TYPE	ODE BRACKET TYPE	MOUNT TYPE	ORIENTATION	SEVERE DUTY	HAZARDOUS LOCATION	DRIP COVER	SCREENS	PAINT
STANDARD	STANDARD	RIGID	HORIZONTAL	PREMIUM SEVERE DUTY	DIVISION 2 T2B	FALSE	NONE	BLUE (EPOXY)

BEARINGS		GREASE	SHAFT TYPE	SPECIAL DE	SPECIAL ODE	SHAFT MATERIAL	FRAME MATERIAL
DE	OPE						
BALL	BALL	POLYREX EM	T	NONE	NONE	1045 HOT ROLLED (C-204)	CAST IRON
6314	6312						

THERMO-PROTECTORS				THERMISTORS	CONTROL	SPACE /n HEATERS
THERMOSTATS	PROTECTORS	WDG RTDs	BRG RTDs			
NONE	NOT	NONE	NONE	NONE	FALSE	NONE VOLTS

If Inverter equals NONE, contact factory for further information

*
N
O
T
E
S
*

INVERTER TORQUE: CONSTANT 2:1 INV. HP SPEED RANGE: NONE
ENCODER: NONE NONE NONE NONE NONE PPR
BRAKE: NONE NONE NONE P/N NONE NONE NONE NONE FT-LB NONE V NONE Hz

DATE: 06/21/2017 08:40:25 AM
 FORM 3531 REV.3 02/07/99
 ** Subject to change without notice.

Data Sheet

Date: 6/19/2017

Customer: _____

Attention: _____

Submitted by: FAREEDA DUDEKULA



365THFS19086

Submittal

Data @ 460 V

Motor Load Data

Load	0%	25%	50%	75%	100%	115%	125%	LR
Current (Amps)	25.0	28.5	37.5	49.0	61.5	70.0	76.0	362
Torque (ft-lb)	0.00	55.0	110	166	222	256	280	445
RPM	1200	1195	1192	1188	1182	1,178	1175	0
Efficiency (%)		91.0	94.1	94.5	94.5	94.1	93.6	
P.F. (%)	4.0	45.0	66.0	76.0	80.5	81.5	82.0	34.0

Motor Speed Data

	LR	Pull-Up	BD	Rated	Idle
Speed (RPM)	0	600	1125	1182	1200
Current (Amps)	362	325	225	61.5	25.0
Torque (ft-lb)	445	425	625	222	0.00

Information Block

HP	50.0			
Sync. RPM	1200			
Frame	365			
Enclosure	TEFC			
Construction	TFS			
Voltage	460 V			
Frequency	60 Hz			
Design	B			
LR Code letter	G			
Service Factor	1.15			
Temp Rise @ FL	70 °C			
Duty	CONT			
Ambient	40 °C			
Elevation	1,000 feet			
Rotor/Shaft wk ²	17.2 Lb-Ft ²			
Ref Wdg	T367601 NONE			
Sound Pressure @ 1M	58 dBA			
VFD Rating	CONSTANT 2:1			
Outline Dwg	B-SS508590-1450			
Conn. Diag	A-EE7300U			
Additional Specifications:				
0				
0				
EQUIV CKT (OHMS / PHASE)				
R1	R2	X1	X2	Xm
0.0790	0.0710	0.4140	0.6750	9.9910

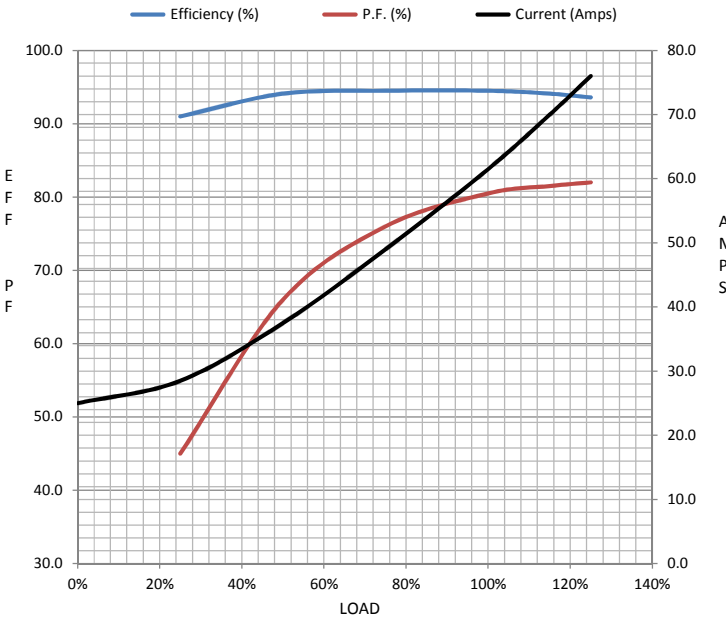

Speed -Torque Curve

