

PRODUCT INFORMATION PACKET

marathon®
Motors

Model No: 364TTGS1036

Catalog No: U969

Other Purpose Motor, 60 & 50 HP, 3 Ph, 60 & 50 Hz, 230/460 & 190/380 V, 1800 & 1500 RPM,
364T Frame, EPFC



Regal and Marathon are trademarks of Regal Rexnord Corporation or one of its affiliated companies.

©2023 Regal Rexnord Corporation, All Rights Reserved. MC017097E

RegalRexnord

Nameplate Specifications

Phase	3	Output HP	60 & 50 Hp
Output KW	45.0 & 37.0 kW	Voltage	230/460 & 190/380 V
Speed	1775 & 1480 rpm	Service Factor	1.15 & 1.15
Frame	364T	Enclosure	Explosion Proof Fan cooled
Thermal Protection	No Protection	Efficiency	93.6 & 93.6 %
Ambient Temperature	40 °C	Frequency	60 & 50 Hz
Current	144/72 & 144/72 A	Power Factor	83
Duty	Continuous	Insulation Class	F
Design Code	B	KVA Code	G
Drive End Bearing Size	6314	Opp Drive End Bearing Size	6312
UL	No	CSA	Y
CE	N	IP Code	54
Number of Speeds	1		

Technical Specifications

Electrical Type	Squirrel Cage Induction Run	Starting Method	Across The Line
Poles	4	Rotation	Reversible
Resistance Main	.1 Ohms	Mounting	Rigid Base
Motor Orientation	Horizontal	Drive End Bearing	Ball
Opp Drive End Bearing	Ball	Frame Material	Cast Iron
Shaft Type	T	Overall Length	31.74 in
Frame Length	13.50 in	Shaft Diameter	2.375 in
Shaft Extension	6.13 in	Assembly/Box Mounting	F1 ONLY
Outline Drawing	B-SS518459-1350	Connection Drawing	A-EE7308K

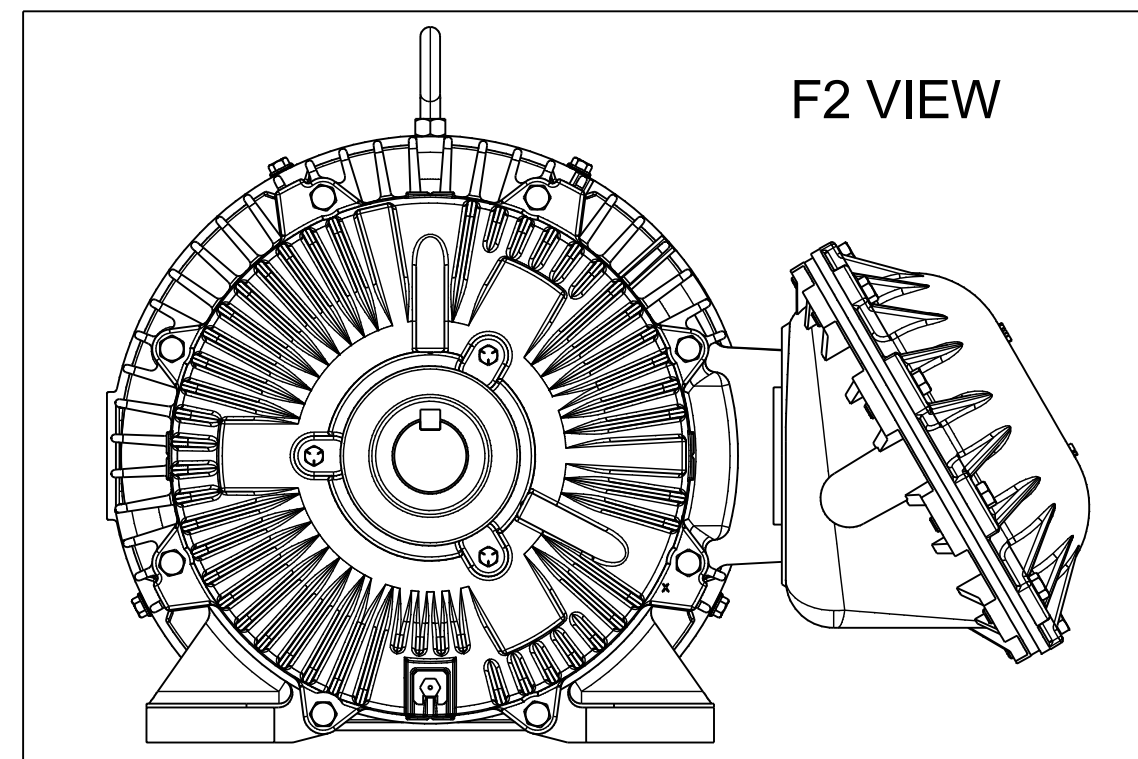
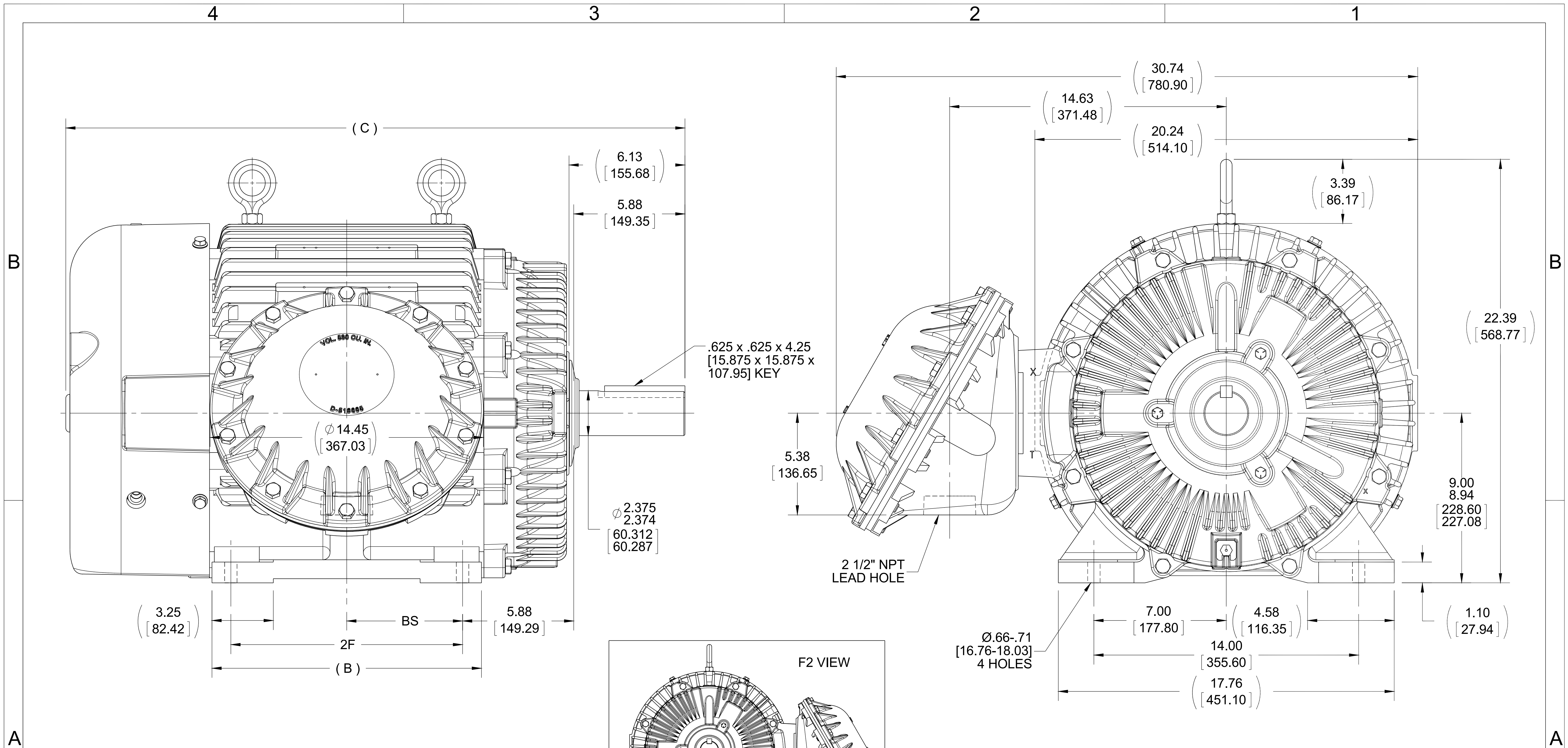

- NOTES:
 1. CONDUIT BOX CAN BE ROTATED IN 90° STEPS.
 2. CONDUIT BOX CAN BE MOUNTED ON OPPOSITE SIDE BY REMOVING BRACKETS AND TURNING FRAME 180°.
 3. NAMEPLATES TO BE READ FROM CONDUIT BOX SIDE OF MOTOR.

DASH	FRAME	B	C	2F	BS
1350	364T	13.25 [336.55]	31.74 [806.20]	11.25 [285.75]	5.62 [142.75]
1450	365T	14.25 [361.95]	32.74 [831.60]	12.25 [311.15]	6.12 [155.45]

DRAWING REVISION G	REVISION BY TDB	DATE 07-28-2015
ECO ECO-0082089	APPROVED BY DJK	DATE 07-30-2015
ECO DESCRIPTION UPDATED TO CURRENT STD'S		
<small>COPYRIGHT REGAL BELOIT AMERICA, INC. ALL RIGHTS RESERVED. PROPRIETARY AND CONFIDENTIAL INFORMATION - THIS DOCUMENT IS THE PROPERTY OF REGAL BELOIT AMERICA, INC. ("OWNER") AND CONTAINS OWNER'S PROPRIETARY INFORMATION. ANY PERSON, CORPORATION OR OTHER FIRM RECEIVING IT IS DEEMED, BY RECEIVING IT, TO AGREE THAT IT, AND/OR ANY PART OF IT, SHALL NOT BE DISCLOSED TO ANY PERSON, CORPORATION OR OTHER ENTITY, DUPLICATED, AND/OR USED, EXCEPT AS EXPRESSLY APPROVED IN WRITING IN ADVANCE BY OWNER. THIS DOCUMENT SHALL BE RETURNED TO OWNER UPON REQUEST. IT MAY BE SUBJECT TO CERTAIN RESTRICTIONS UNDER APPLICABLE EXPORT CONTROL LAWS AND REGULATIONS.</small>		

TOLERANCES UNLESS OTHERWISE SPECIFIED:			
DEC.	INCH	mm	ANGLE
.X	±0.1	[±2.5]	±7° 30"
.XX	±0.03	[±0.76]	
.XXX	±0.005	[±0.127]	
.XXXX	±0.0005	[±0.0127]	
REMOVE BURRS & BREAK SHARP EDGES: .003/.015 [0.076/.381] X 45°			
CORNER FILLETS: R.02 [0.51]			
MACHINED SURFACES: 200 INCH/mm 5.1			
mm SHOWN IN [BRACKETS]			

DRAWN BY TJB
DATE 05-14-2001
APPROVED BY GK
DATE 09-07-2001
REFERENCE
THIRD ANGLE PROJECTION

REGAL ™ Regal Beloit America, Inc.	
DESCRIPTION OUTLINE 360T FR. - EXP. PROOF	
MATERIAL	PROCESS/FINISH
SIZE B	DRAWING NUMBER SS518459
SHEET 1 OF 1	

LOW VOLTAGE



HIGH VOLTAGE



VIEW OF TERMINAL END

			TOLERANCES UNLESS SPECIFIED		 REGAL - BELOIT CORPORATION	DRAWN PGK 06-04-1997			
NO.	REVISION	BY & DATE	CHK	ANG		±	INCHES	SCALE	PREV
E	CORRECTED IEC MARKINGS ECD-0111208	WGJ 01-23-2017	EMH	DEC.				CHK ML 06-05-1997	
D	RE-DRAWN WITH REGAL LOGO ECD-0110493	WGJ 09-30-2016	EMH	.X	±.1			APPD GK 06-15-1997	
8	ADDED IEC DESIGNATIONS MU95020	TJW 4/30/2010	MJS	.XX	±.02		TITLE CONNECTION DIAGRAM		
7	REVISED HIGH VOLTAGE L2 WAS L3 CN52600-354	MRB 09-21-1998		.XXX	±.005		TITLE DELTA CON. - 3Ø - 9 LEADS	REF	
6	REDRAWN ON CADD	PGK 06-05-1997		.XXXX	±.0005		MAT'L.	FMF	
					±7'30"		FINISH		
THIS DRAWING IN DESIGN AND DETAIL IS OUR PROPERTY AND MUST NOT BE USED EXCEPT IN CONNECTION WITH OUR WORK ALL RIGHTS OF DESIGN AND INVENTION ARE RESERVED THIS IS AN ELECTRONICALLY GENERATED DOCUMENT - DO NOT SCALE THIS PRINT			RFP	CAD FILE EE7308K			SIZE A	DRAWING NO. EE7308K	PAGE OF REV. E
			DIST						



P.O. BOX 8003
WAUSAU, WI 54401-8003
PH. 715-875-3311

DATA VOLTS: 460

CERTIFICATION DATA SHEET

CUSTOMER: _____
ORDER #: _____
CONN. DIAGRAM: A-EE7308K
OUTLINE: B-SS518459-1350
WINDING: T3644133 NONE 1
SPEED: _____

CUSTOMER P.O. #: _____
REFERENCE MODEL #: 364TTGS1036
CAT #: U969
CUSTOMER PART #: _____
MOUNTING: F1 ONLY

TYPICAL MOTOR PERFORMANCE DATA

HP	KW	SYNC RPM	FL RPM	FRAME	ENCLOSURE	TYPE	KVA CODE	DESIGN
60	45	1800	1775	364T	EPFC	TFS	G	BC

PH	HZ	VOLTS	AMPS	START TYPE	DUTY	INSL	S.F.	AMB	ELEV.
3	60/50	230/460#190/380	144/72&144/72	ACROSS THE LINE	CONT	F	1.15	40	3300

F.L. EFF	3/4 LD EFF	1/2 LD EFF	GTD EFF	ELECT. TYPE
93.6	93.6	92.4	92.4	SQ CAGE IND RUN
F.L. PF	3/4 LD PF	1/2 LD PF		
83.0	80.0	72.0		

F.L. TORQUE	LR AMPS @ 460 V	L.R. TORQUE	B.D. TORQUE	F.L. RISE (° C)
177 LB-FT	435	375 LB-FT	475 LB-FT	75
		212%	268%	

SOUND PRESSURE @ 3 FT.	POWER	ROTOR WK ²	MAX. LOAD WK ²	SAFE STALL TIME	STARTS/HOUR	APROX. MOTOR WGT
68 dBA	77 dBA	14.5 LB-FT ²	420 LB-FT ²	25 SEC.	2	975 LB.

*** SUPPLEMENTAL INFORMATION ***

DE BRACKET TYPE	ODE BRACKET TYPE	MOUNT TYPE	MOTOR ORIENTATION	SEVERE DUTY	HAZARDOUS LOCATION	DRIP COVER	SCREENS	PAINT
STANDARD	STANDARD	RIGID	HORIZONTAL	TRUE	DIV 1 EXP PROOF CL I GR CD T2A	NO	NONE	BLUE - RAL 5003 (EPOXY)

BEARINGS	GREASE	SHAFT TYPE	SPECIAL DE	SPECIAL ODE	SHAFT MATERIAL	FRAME MATERIAL
DE BALL 6314	POLYREX EM	T	NONE	NONE	1045 HOT ROLLED (C-204)	CAST IRON

THERMOSTATS	PROTECTORS	WDG RTD's	BRG RTD's	THERMISTORS	CONTROL	SPACE HEATERS
NONE	NOT	NONE	NONE	NONE	FALSE	NA

R1 (ohms/ph)	R2 (ohms/ph)	X1 (ohms/ph)	X2 (ohms/ph)	Xm (ohms/ph)	VIBRATION (in/sec)	FLOAT
0.07	0.047	0.38	0.482	9.626	0.150	ODE

* N O T E S *	INVERTER TORQUE: NONE	
	INV. HP SPEED RANGE: NONE	
	ENCODER: NONE	
	NONE	NONE PPR
	NONE	

PREPARED BY: _____	BRAKE: NONE	
DATE: 1/24/2023	NONE	NONE
	FT-LB: NA	
	VOLTAGE: NONE	HZ: _____
	UL: NONE	

FORM: 3531 REV 4 2/27/06