

# PRODUCT INFORMATION PACKET

Model No: 364TTFS6086

Catalog No: E241

Other Purpose Motor, 40 HP, 3 Ph, 60 Hz, 230/460 V, 1200 RPM, 364T Frame, TEFC

Regal and are trademarks of Regal Rexnord Corporation or one of its affiliated companies.  
©2022 Regal Rexnord Corporation, All Rights Reserved. MC017097E



### Nameplate Specifications

Output HP	<b>40 Hp</b>	Output KW	<b>30.0 kW</b>
Frequency	<b>60 Hz</b>	Voltage	<b>230/460 V</b>
Current	<b>100.0/50.0 A</b>	Speed	<b>1182 rpm</b>
Service Factor	<b>1.15</b>	Phase	<b>3</b>
Efficiency	<b>93.6 %</b>	Power Factor	<b>80</b>
Duty	<b>Continuous</b>	Insulation Class	<b>F</b>
Design Code	<b>B</b>	KVA Code	<b>G</b>
Frame	<b>364T</b>	Enclosure	<b>Totally Enclosed Fan Cooled</b>
Thermal Protection	<b>No Protection</b>	Ambient Temperature	<b>40 °C</b>
Drive End Bearing Size	<b>6314</b>	Opp Drive End Bearing Size	<b>6312</b>
UL	<b>Recognized</b>	CSA	<b>Y</b>
CE	<b>Y</b>	IP Code	<b>43</b>
Number of Speeds	<b>1</b>		

### Technical Specifications

Electrical Type	<b>Squirrel Cage Induction Run</b>	Starting Method	<b>Across The Line</b>
Poles	<b>6</b>	Rotation	<b>Reversible</b>
Resistance Main	<b>.162 Ohms</b>	Mounting	<b>Rigid Base</b>
Motor Orientation	<b>Horizontal</b>	Drive End Bearing	<b>Ball</b>
Opp Drive End Bearing	<b>Ball</b>	Frame Material	<b>Cast Iron</b>
Shaft Type	<b>T</b>	Overall Length	<b>31.51 in</b>
Frame Length	<b>13.50 in</b>	Shaft Diameter	<b>2.375 in</b>
Shaft Extension	<b>6.12 in</b>	Assembly/Box Mounting	<b>F1/F2 CAPABLE</b>
Connection Drawing	<b>A-EE7308</b>	Outline Drawing	<b>B-SS508590-1350</b>

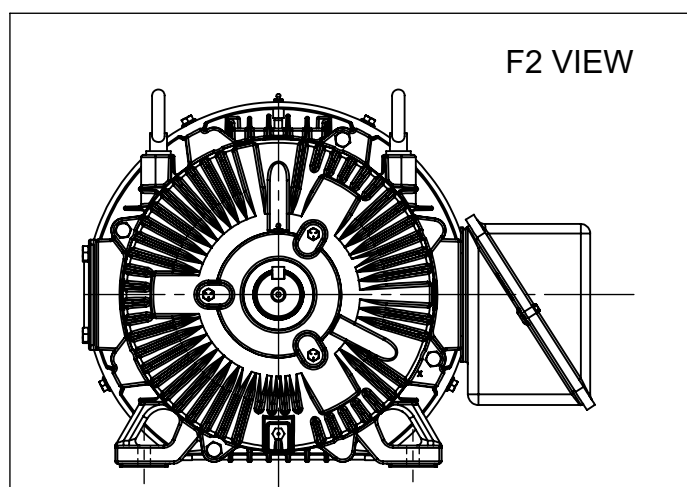
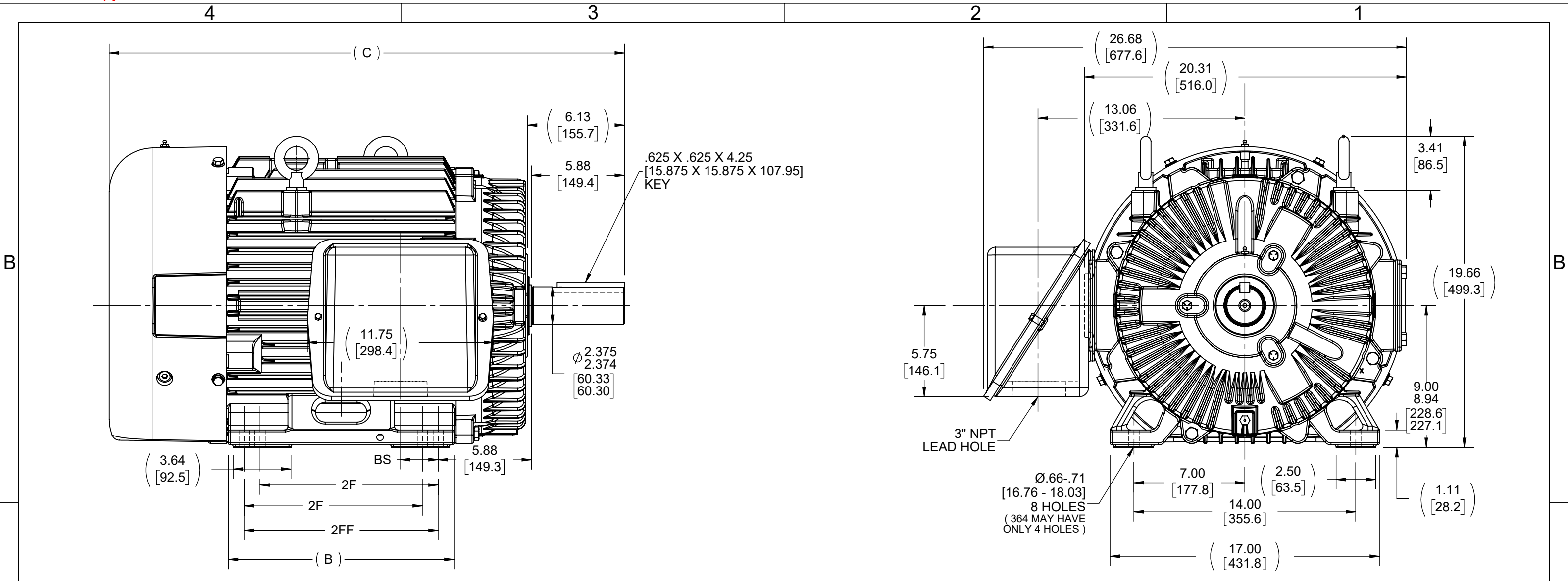

FRAME 364 - 1350

NOTE:  
 1. ALTERNATE FRAME DRAWING.  
 2. MODELS USING ALTERNATE FRAME 553485A.

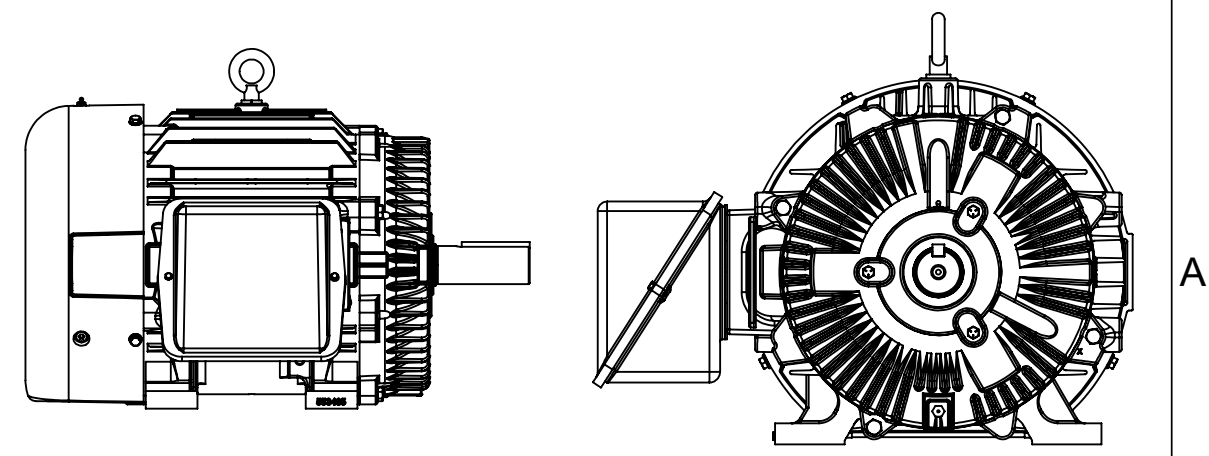

NOTES:  
 1. CONDUIT BOX CAN BE ROTATED IN 90° STEPS.

DASH	FRAME	B	C	2F	2FF	BS
1350	364T	13.25 [336.55]	31.51 [800.35]	11.25 [285.75]	---	5.62 [142.74]
1450	364/365T	14.25 [361.95]	32.51 [825.75]	11.25 [285.75]	12.25 [311.15]	2.38 [60.45]

DRAWING REVISION 1	REVISION BY MJ	REV DATE/© DATE 05/04/2022	TOLERANCES (EXCEPT AS NOTED): DEC. INCH mm ANGLE .X ±0.1 [±3] ±7° 30" .XX ±0.03 [±0.8] .XXX ±0.005 [±0.13] .XXXX ±0.0005 [±0.013] REMOVE BURRS & BREAK SHARP EDGES: .003/.015 [.08/.38] X 45° CORNER FILLETS: R.02 [.5] MACHINED SURFACES: 200 INCH/mm 5.1 mm DIMENSIONS IN [BRACKETS] ARE FOR REFERENCE ONLY	DRAWN BY TLB			DRAWING NUMBER SS508590	SHEET 1 OF 1
REQUEST NUMBER CR-0007552	APPROVED BY VJ	DATE 05/04/2022		DATE 01-29-1988				
REQUEST NUMBER DESCRIPTION OUTLINE DRAWING IS UPDATED WITH NEW FRAME.				APPROVED BY ML			DESCRIPTION 360T FR. - TEFC - TAPPED LEAD HOLE	
COPYRIGHT (PER REVISION DATE) REGAL BELOIT AMERICA, INC. ALL RIGHTS RESERVED. PROPRIETARY AND CONFIDENTIAL INFORMATION - THIS DOCUMENT IS THE PROPERTY OF REGAL BELOIT AMERICA, INC. ("OWNER") AND CONTAINS OWNER'S PROPRIETARY INFORMATION. ANY PERSON, CORPORATION OR OTHER FIRM RECEIVING IT IS DEEMED, BY RECEIVING IT, TO AGREE THAT IT, AND/OR ANY PART OF IT, SHALL NOT BE DISCLOSED TO ANY PERSON, CORPORATION OR OTHER ENTITY, DUPLICATED, AND/OR USED, EXCEPT AS EXPRESSLY APPROVED IN WRITING IN ADVANCE BY OWNER. THIS DOCUMENT SHALL BE RETURNED TO OWNER UPON REQUEST. IT MAY BE SUBJECT TO CERTAIN RESTRICTIONS UNDER APPLICABLE EXPORT CONTROL LAWS AND REGULATIONS.				DATE 01-29-1988				
				REFERENCE				

EE7308

THREE PHASE  
DUAL VOLTAGE MOTOR



VIEW OF TERMINAL END

REF.  
WINDING DIAGRAM

T8Y, T2Y, T2BL, T4BX, T2EC, T2G  
T6BZ, T2B, T6BL, T4AV, T6B, T4B

OPTIONAL CORD  
CONNECTION

L1 — WHITE  
L2 — RED  
L3 — BLACK

NO.	REVISION	BY & DATE	CHK	ANG	TOLERANCES UNLESS SPECIFIED		FINISH	DRAWN RM 11/20/1990				
					DEC.	INCHES						
5	CHG TO REGAL LOGO	SL 09/10/2015	AB					CHK ML 11/21/1990				
4	REVISED IEC NOTATIONS	MSG 11/15/2011	CMN	.X	±.1			APPD SAS 04/24/2003				
3	ADDED IEC NOTATIONS... (U1), (V1) ETC. MU95194	MSG 5/10/2010	MJS	.XX	±.02			SCALE 1=1				
2	ADDED THE OPTIONAL CORD CONNECTION MU46318	RDH 04/24/2003	DRS	.XXX	±.005		TITLE CONNECTION DIAGRAM 3Ø - DUAL VOLTAGE MOTOR	REF				
1	REDRAWN	RM 11/20/1990		.XXXX	±.0005		MAT'L.	FMF				
					±7'30"			PREV				
THIS DRAWING IN DESIGN AND DETAIL IS OUR PROPERTY AND MUST NOT BE USED EXCEPT IN CONNECTION WITH OUR WORK ALL RIGHTS OF DESIGN AND INVENTION ARE RESERVED THIS IS AN ELECTRONICALLY GENERATED DOCUMENT - DO NOT SCALE THIS PRINT							RFP	CAD FILE ee7308	SIZE A	DRAWING NO. EE7308	PAGE OF 5	REV. 5
							DIST WP					



Regal Beloit America, Inc.