

PRODUCT INFORMATION PACKET

Model No: 326TTTS18577

Catalog No: S528

Other Purpose Motor, 30 HP, 3 Ph, 60 Hz, 460 V, 1200 RPM, 326T Frame, TEAO



Regal and are trademarks of Regal Rexnord Corporation or one of its affiliated companies.
©2022 Regal Rexnord Corporation, All Rights Reserved. MC017097E

Nameplate Specifications

Output HP	30 Hp	Output KW	22.4 kW
Frequency	60 Hz	Voltage	460 V
Current	38.5 A	Speed	1182 rpm
Service Factor	1.15	Phase	3
Efficiency	93 %	Power Factor	79
Duty	Continuous	Insulation Class	H
Design Code	B	KVA Code	G
Frame	326T	Enclosure	Totally Enclosed Air Over
Thermal Protection	No Protection	Ambient Temperature	90 °C
Drive End Bearing Size	6312	Opp Drive End Bearing Size	6311
UL	No	CSA	Y
CE	N	IP Code	54
Number of Speeds	1		

Technical Specifications

Electrical Type	Squirrel Cage Inverter Rated	Starting Method	Line Or Inverter
Poles	6	Rotation	Reversible
Resistance Main	.21 Ohms	Mounting	Rigid Base
Motor Orientation	Horizontal	Drive End Bearing	Ball / Heat Stabilized
Opp Drive End Bearing	Ball / Heat Stabilized	Frame Material	Cast Iron
Shaft Type	T	Overall Length	27.50 in
Frame Length	13.00 in	Shaft Diameter	2.125 in
Shaft Extension	5.5 in	Assembly/Box Mounting	F1/F2 Capable
Connection Drawing	A-EE7300S	Outline Drawing	B-SS301011-1300

This is an uncontrolled document once printed or downloaded and is subject to change without notice. Date Created:09/07/2022

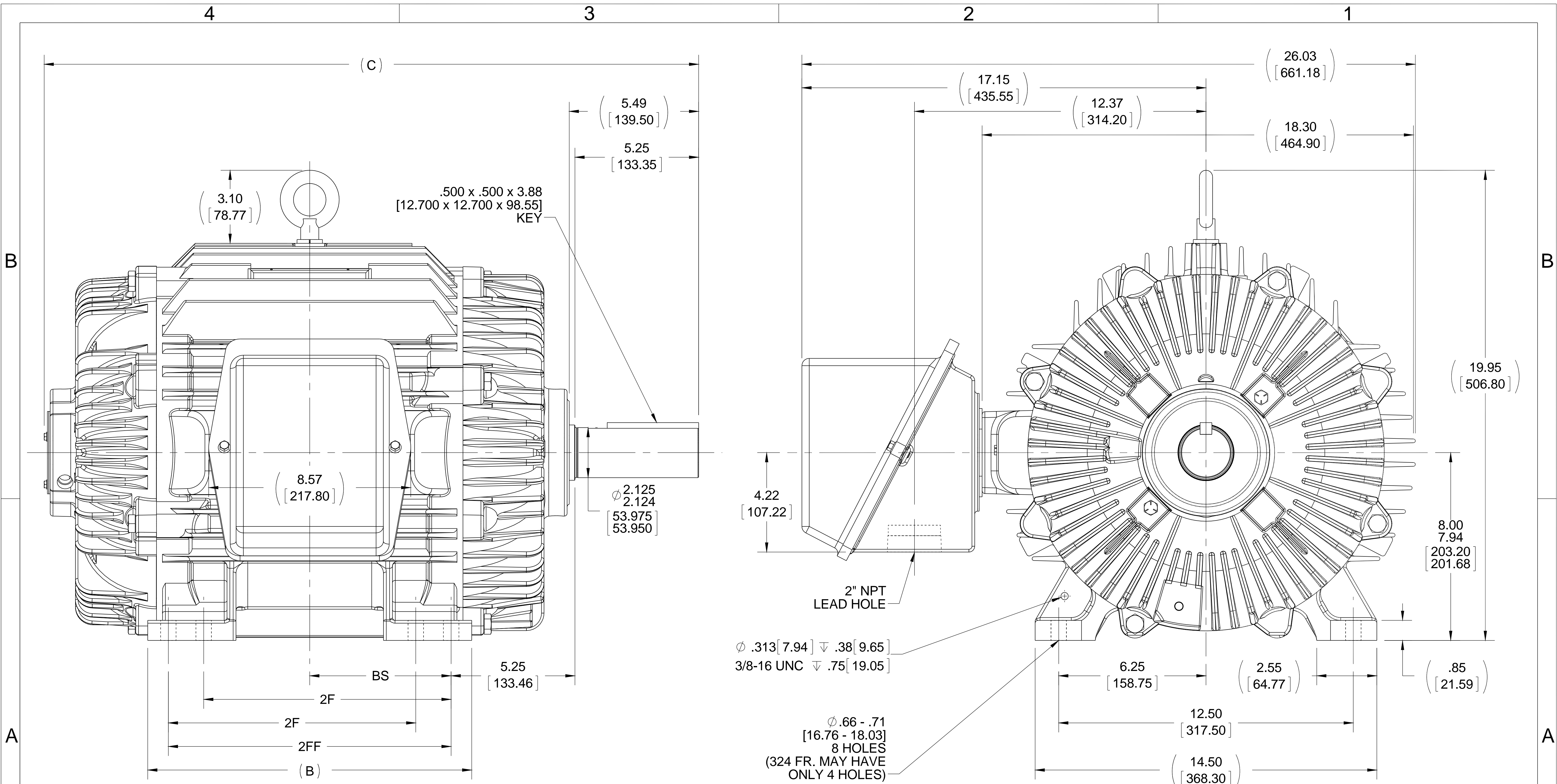

- NOTES:
 1. CONDUIT BOX CAN BE ROTATED IN 90° STEPS.
 2. CONDUIT BOX CAN BE MOUNTED ON OPPOSITE BY REMOVING BRACKETS AND TURNING FRAME 180°.
 3. NAMEPLATE TO BE READ FROM CONDUIT BOX SIDE OF MOTOR.

DASH	FRAME	B	C	2F	2FF	BS
1150	324T	13.00 [330.20]	26.27 [667.26]	---	10.50 [266.70]	5.25 [133.35]
1300	324T/ 326T	13.75 [349.25]	27.77 [705.36]	10.50 [266.70]	12.00 [304.80]	6.00 [152.40]

DRAWING REVISION F	REVISION BY J. OTTO	DATE 06-27-2016
ECO ECO-0102388	APPROVED BY T. VUE	DATE 06-28-2016
ECO DESCRIPTION NMR-0106886, MU123088		
<small>COPYRIGHT REGAL BELOIT AMERICA, INC. ALL RIGHTS RESERVED. PROPRIETARY AND CONFIDENTIAL INFORMATION - THIS DOCUMENT IS THE PROPERTY OF REGAL BELOIT AMERICA, INC. ("OWNER") AND CONTAINS OWNER'S PROPRIETARY INFORMATION. ANY PERSON, CORPORATION OR OTHER FIRM RECEIVING IT IS DEEMED, BY RECEIVING IT, TO AGREE THAT IT, AND/OR ANY PART OF IT, SHALL NOT BE DISCLOSED TO ANY PERSON, CORPORATION OR OTHER ENTITY, DUPLICATED, AND/OR USED, EXCEPT AS EXPRESSLY APPROVED IN WRITING IN ADVANCE BY OWNER. THIS DOCUMENT SHALL BE RETURNED TO OWNER UPON REQUEST. IT MAY BE SUBJECT TO CERTAIN RESTRICTIONS UNDER APPLICABLE EXPORT CONTROL LAWS AND REGULATIONS.</small>		

TOLERANCES UNLESS OTHERWISE SPECIFIED:

DEC.	INCH	mm	ANGLE
.X	±0.1	[±2.5]	±7° 30"
.XX	±0.03	[±0.76]	
.XXX	±0.005	[±0.127]	
.XXXX	±0.0005	[±0.0127]	

REMOVE BURRS & BREAK SHARP EDGES: .003/.015 [0.076/.381] X 45°
 CORNER FILLETS: R.02 [0.51]
 MACHINED SURFACES: 200 INCH/mm 5.1
 mm SHOWN IN [BRACKETS]

DRAWN BY CAV
DATE 08-29-2000
APPROVED BY DD
DATE 08-30-2000
REFERENCE
THIRD ANGLE PROJECTION

REGAL ™ Regal Beloit America, Inc.	
DESCRIPTION OUTLINE 320T FR. - TEAO - TENV - 14.25 LAM.	
MATERIAL	PROCESS/FINISH
SIZE B	DRAWING NUMBER SS301011
	SHEET 1 OF 1

EE7300S

THREE PHASE – SINGLE VOLTAGE MOTOR

TO REVERSE ROTATION:
INTERCHANGE ANY TWO LINE
LEAD CONNECTIONS

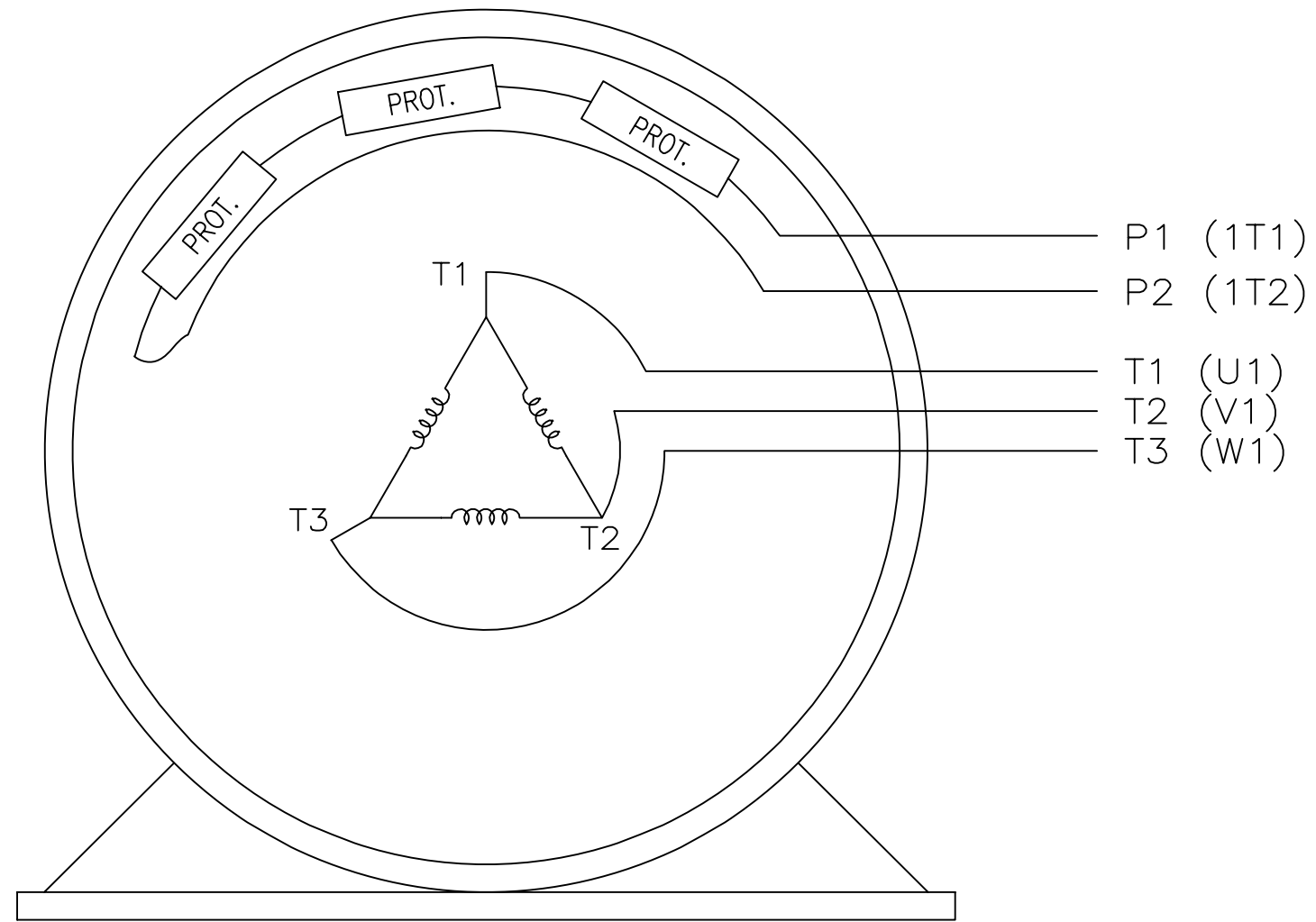

IF MOTOR HAS MULTIPLE
T'S PER LEAD CONNECT
TOGETHER LIKE T'S

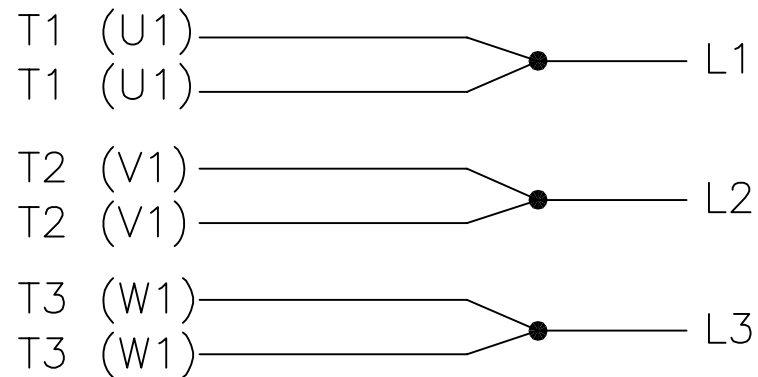

A-9806 DECAL

VIEW OF TERMINAL END

NO.	REVISION	BY & DATE	CHK	TOLERANCES UNLESS SPECIFIED			REGAL-BELOIT CORPORATION	DRAWN KL 12-15-1999			
				DEC.	INCHES						
F	UPDATED TITLE BLOCK	HV 02-27-2014	EWH	.X	±	-	REGAL-BELOIT CORPORATION	CHK DJK 12-15-1999			
3	REMOVED "N.C." FROM PROT.'S MU61770	JJB 08-02-2010		.XX	±	-	TITLE CONNECTION DIAGRAM – EXTERNAL SINGLE VOLTAGE 3Ø MOTOR	APPD DJK 12-15-1999			
2	ADDED IEC MARKINGS MU61770	KL 09-16-2004	EAB	.XXX	±	-		SCALE 1=1			
1	NEW DRAWING	KL 12-16-1999		.XXXX	±	-		REF			
							MAT'L.	FMF			
							FINISH	PREV			
THIS DRAWING IN DESIGN AND DETAIL IS OUR PROPERTY AND MUST NOT BE USED EXCEPT IN CONNECTION WITH OUR WORK ALL RIGHTS OF DESIGN AND INVENTION ARE RESERVED THIS IS AN ELECTRONICALLY GENERATED DOCUMENT – DO NOT SCALE THIS PRINT				RFP	CAD FILE ee7300s			SIZE A	DRAWING NO. EE7300S	PAGE OF	REV. F
				DIST	WA-LB-SB						

Data Sheet

Date: 6/19/2017

326TTTS18577

Customer: _____

Attention: _____

Submitted by: FAREEDA DUDEKULA



Submittal

Data @ 460 V

Motor Load Data

Load	0%	25%	50%	75%	100%	115%	125%	LR
Current (Amps)	15.0	17.5	23.0	30.0	38.5	43.5	47.5	217
Torque (ft-lb)	0.00	33.0	66.0	100	134	154	168	200
RPM	1200	1195	1190	1185	1182	1,178	1175	0
Efficiency (%)		88.5	92.4	93.0	93.0	92.4	91.7	
P.F. (%)	5.0	46.0	66.0	75.0	79.0	80.0	80.5	30.0

Motor Speed Data

	LR	Pull-Up	BD	Rated	Idle
Speed (RPM)	0	600	1100	1182	1200
Current (Amps)	217	200	140	38.5	15.0
Torque (ft-lb)	200	175	375	134	0.00

Information Block				
HP	30.0			
Sync. RPM	1200			
Frame	326			
Enclosure	TEAO			
Construction	TTN			
Voltage	460 V			
Frequency	60 Hz			
Design	B			
LR Code letter	G			
Service Factor	1.15			
Temp Rise @ FL	0 °C			
Duty	CONT			
Ambient	40 °C			
Elevation	1,000 feet			
Rotor/Shaft wk ²	9.4 Lb-Ft ²			
Ref Wdg	3266122 NONE			
Sound Pressure @ 1M	999 dBA			
VFD Rating	VARIABLE 20:1			
Outline Dwg	B-SS301011-1300			
Conn. Diag	A-EE7300S			
Additional Specifications:				
0				
0				
EQUIV CKT (OHMS / PHASE)				
R1	R2	X1	X2	Xm
0.1470	0.1210	0.9130	1.1540	16.2710

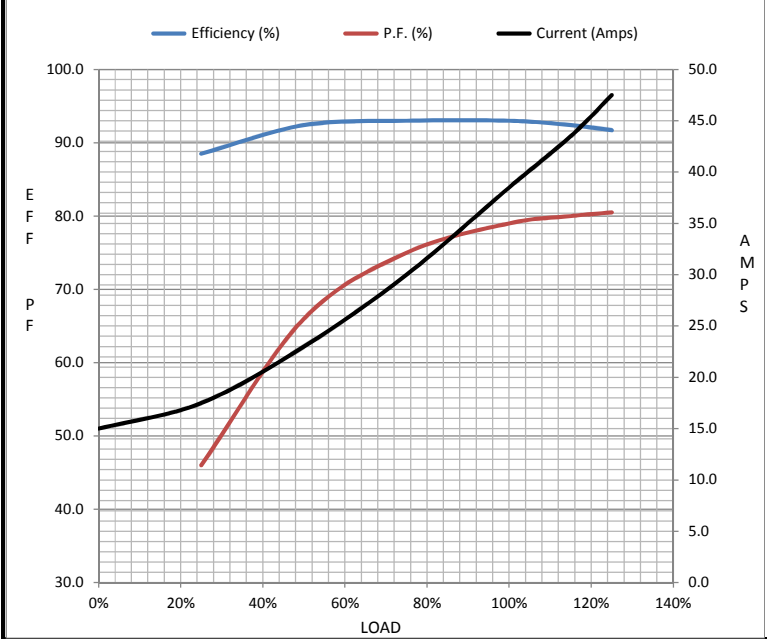

Speed - Torque Curve

