

PRODUCT INFORMATION PACKET

Model No: 326TTDR7302

Catalog No: M837

Other Purpose Motor, 60 HP, 3 Ph, 60 Hz, 230/460 V, 3600 RPM, 326HPV Frame, DP

Regal and are trademarks of Regal Rexnord Corporation or one of its affiliated companies.
©2022 Regal Rexnord Corporation, All Rights Reserved. MC017097E



Nameplate Specifications

Output HP	60 Hp	Output KW	45.0 kW
Frequency	60 Hz	Voltage	230/460 V
Current	144.0/72.0 A	Speed	3550 rpm
Service Factor	1.15	Phase	3
Efficiency	90.2 %	Power Factor	84
Duty	Continuous	Insulation Class	B
Design Code	B	KVA Code	F
Frame	326HPV	Enclosure	Drip Proof
Thermal Protection	No Protection	Ambient Temperature	40 °C
Drive End Bearing Size	6311	Opp Drive End Bearing Size	6311
UL	Recognized	CSA	Y
CE	Y	IP Code	22
Number of Speeds	1		

Technical Specifications

Electrical Type	Squirrel Cage Induction Run	Starting Method	Across The Line
Poles	2	Rotation	Reversible
Resistance Main	.19 Ohms	Mounting	Round
Motor Orientation	Shaft Down	Drive End Bearing	Ball
Opp Drive End Bearing	Ball	Frame Material	Rolled Steel
Shaft Type	HP	Overall Length	29.56 in
Frame Length	14.00 in	Shaft Diameter	1.625 in
Shaft Extension	4.5 in	Assembly/Box Mounting	F1/F2 CAPABLE
Connection Drawing	A-EE7308K	Outline Drawing	B-SS28314-1400

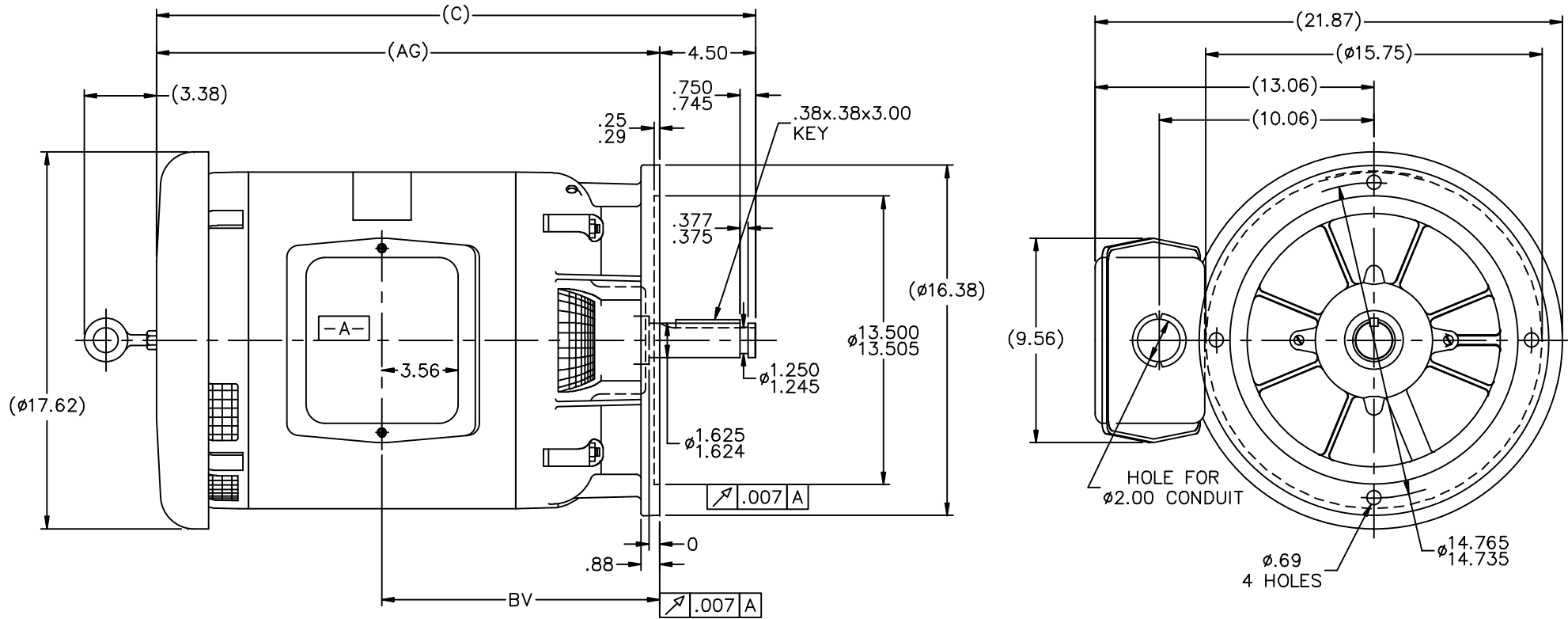

- NOTES:
 1. C'BOX CAN BE ROTATED IN 90° STEP.
 2. NAMEPLATE TO BE READ FROM SHAFT END OF MOTOR
 3. MAX. SHAFT RUNOUT .002

DASH	FRAME	C	AG	BV
1250	320	28.06	23.56	13.00
1400	320	29.56	25.06	13.75
1450	320	30.06	25.56	14.00
1500	320	30.56	26.06	14.12

16	REVISED NOTE # 2 (ECN 23047)	REP 01-16-2012	BW	TOLERANCES UNLESS SPECIFIED		DRAWN MJD 01-27-1999				
15	ECN 16735	NJS 6/21/2010	BW	DEC. INCHES		CHK ML 02-01-1999				
14	REVISED NAMEPLATE LOCATION 09-3901	MSG 9/22/2009	DR	.X ±.1		APPD DD 02-01-1999				
13	REDRAWN IN AUTOCAD	TAT 07-22-2004	ML	.XX ±.03		SCALE 7=32				
12	REVISED TO NEC CONDUIT BOX CN 2842B	BJW 02-04-2000	.XXX	±.005		REF				
11	FRAME TYPES NOW 320 CN 27400-327	DRS 08-23-1999	.XXXX	±.0005	MAT'L	FMF				
NO.	REVISION	BY & DATE	CHK	ANG	FINISH	PREV				
THIS DRAWING IN DESIGN AND DETAIL IS OUR PROPERTY AND MUST NOT BE USED EXCEPT IN CONNECTION WITH OUR WORK ALL RIGHTS OF DESIGN AND INVENTION ARE RESERVED THIS IS AN ELECTRONICALLY GENERATED DOCUMENT - DO NOT SCALE THIS PRINT					RFP	CAD FILE ss28314	SIZE B	DRAWING NO. SS28314	PAGE OF	REV. 16
					DIST LB					

LOW VOLTAGE



HIGH VOLTAGE



VIEW OF TERMINAL END

			TOLERANCES UNLESS SPECIFIED		 REGAL - BELOIT CORPORATION	DRAWN PGK 06-04-1997					
NO.	REVISION	BY & DATE	CHK	ANG		±	INCHES	SCALE	PREV		
E	CORRECTED IEC MARKINGS ECD-0111208	WGJ 01-23-2017	EMH	DEC.				CHK ML 06-05-1997			
D	RE-DRAWN WITH REGAL LOGO ECD-0110493	WGJ 09-30-2016	EMH	.X	±.1			APPD GK 06-15-1997			
8	ADDED IEC DESIGNATIONS MU95020	TJW 4/30/2010	MJS	.XX	±.02		TITLE CONNECTION DIAGRAM				
7	REVISED HIGH VOLTAGE L2 WAS L3 CN52600-354	MRB 09-21-1998		.XXX	±.005		TITLE DELTA CON. - 3Ø - 9 LEADS	REF			
6	REDRAWN ON CADD	PGK 06-05-1997		.XXXX	±.0005		MAT'L.	FMF			
					±7'30"		FINISH				
THIS DRAWING IN DESIGN AND DETAIL IS OUR PROPERTY AND MUST NOT BE USED EXCEPT IN CONNECTION WITH OUR WORK ALL RIGHTS OF DESIGN AND INVENTION ARE RESERVED THIS IS AN ELECTRONICALLY GENERATED DOCUMENT - DO NOT SCALE THIS PRINT					RFP	CAD FILE EE7308K		SIZE A	DRAWING NO. EE7308K	PAGE OF	REV. E
					DIST						