

PRODUCT INFORMATION PACKET

Model No: 326TSTGP1001

Catalog No: U965

Other Purpose Motor, 50 HP, 3 Ph, 60 Hz, 230/460 V, 3600 RPM, 326TS Frame, EPFC



Regal and are trademarks of Regal Rexnord Corporation or one of its affiliated companies.
©2022 Regal Rexnord Corporation, All Rights Reserved. MC017097E

Nameplate Specifications

Output HP	50 Hp	Output KW	37.0 kW
Frequency	60 Hz	Voltage	230/460 V
Current	115.0/57.5 A	Speed	3540 rpm
Service Factor	1.15	Phase	3
Efficiency	92.4 %	Power Factor	88.5
Duty	Continuous	Insulation Class	F
Design Code	B	KVA Code	G
Frame	326TS	Enclosure	Explosion Proof Fan cooled
Thermal Protection	No Protection	Ambient Temperature	40 °C
Drive End Bearing Size	6312	Opp Drive End Bearing Size	6311
UL	No	CSA	Y
CE	N	IP Code	54
Hazardous Location	EXP PROOF CL I GR C&D T2A	Number of Speeds	1

Technical Specifications

Electrical Type	Squirrel Cage Inverter Rated	Starting Method	Line Or Inverter
Poles	2	Rotation	Reversible
Resistance Main	.162 Ohms	Mounting	Rigid Base
Motor Orientation	Horizontal	Drive End Bearing	Ball
Opp Drive End Bearing	Ball	Frame Material	Cast Iron
Shaft Type	TS	Overall Length	28.97 in
Frame Length	16.25 in	Shaft Diameter	1.875 in
Shaft Extension	3.93 in	Assembly/Box Mounting	F1 ONLY
Inverter Load	CONSTANT 2:1		
Connection Drawing	A-EE7308K	Outline Drawing	B-SS311002-1625

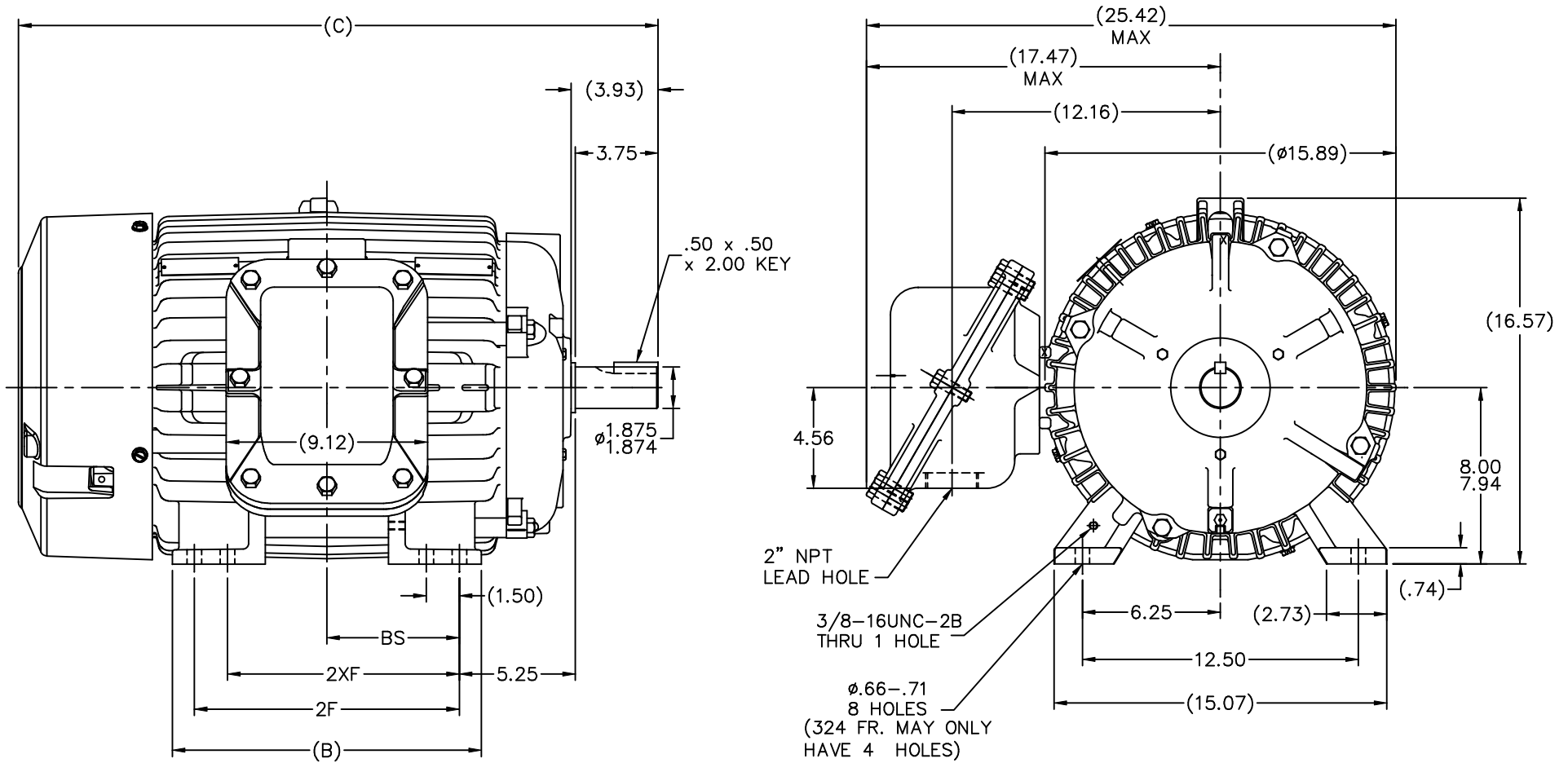

- NOTES:
 1. BOX CAN ONLY BE ROTATED CLOCKWISE UP TO 270° FROM ITS ORIGINAL POSITION.
 2. NAMEPLATE TO BE READ FROM CONDUIT BOX SIDE OF MOTOR.

DASH	FRAME	B	C	2F	2XF	BS
1475	324TS	14.00	27.47	10.50		5.25
1625	326TS	14.00	28.97	12.00	10.50	6.00

		TOLERANCES UNLESS SPECIFIED		MARATHON ELECTRIC		DRAWN DA 03-25-1999			
NO.	REVISION	BY & DATE	CHK	ANG	FINISH	PREV			
5	REDRAWN IN AUTOCAD	TAT 06-28-2004	ML	DEC.	INCHES		CHK ML 04-14-1999		
4	DASH 1475 (B) 14.00 WAS 12.50	CN 29200-1468	HLB	02-26-2001	.X	±.1	APPD SW 04-14-1999		
3	UPDATED 'C' BOX GEOMETRY PER CAST. CHG. CN 29010	DRS 01-31-2000		.XX	±.03		SCALE 7-32		
2	REVISED 'C' DIMENSION FOR C.I. FAN GUARD.	DA 07-12-1999		.XXX	±.005		REF		
	REVISED CONDUIT BOX	CN 2700-239		.XXXX	±.0005		FMF		
					±7'30"		PREV		
THIS DRAWING IN DESIGN AND DETAIL IS OUR PROPERTY AND MUST NOT BE USED EXCEPT IN CONNECTION WITH OUR WORK ALL RIGHTS OF DESIGN AND INVENTION ARE RESERVED THIS IS AN ELECTRONICALLY GENERATED DOCUMENT - DO NOT SCALE THIS PRINT						CAD FILE ss311002	SIZE B	DRAWING NO. SS311002	PAGE OF 5

LOW VOLTAGE

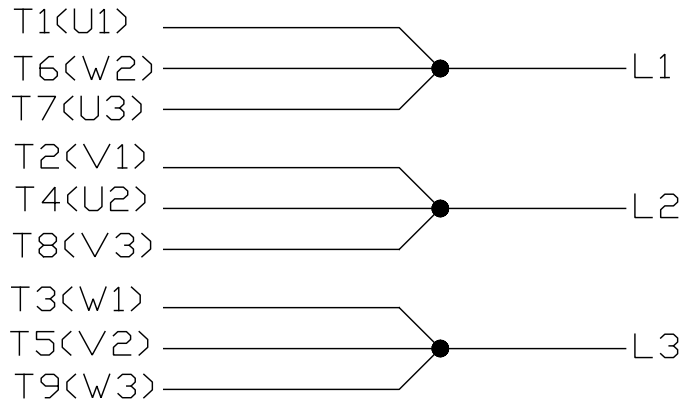

HIGH VOLTAGE

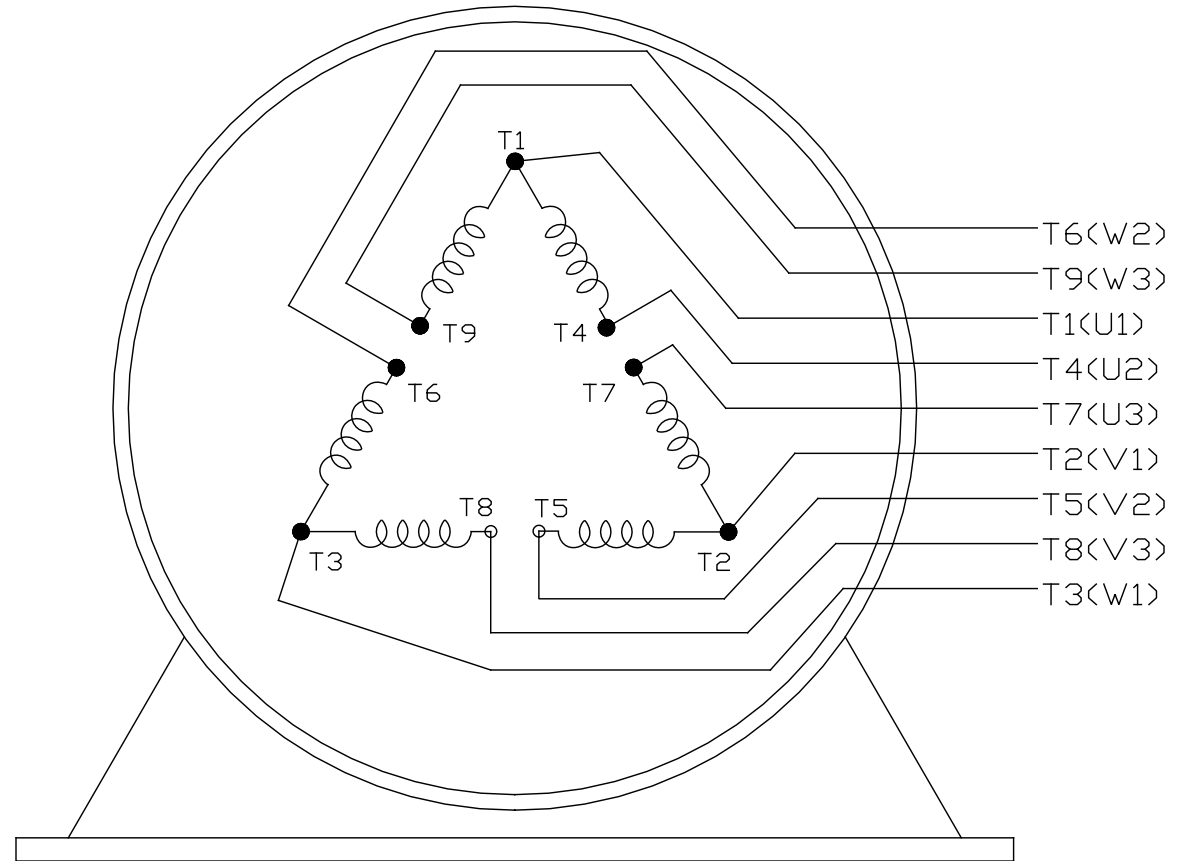
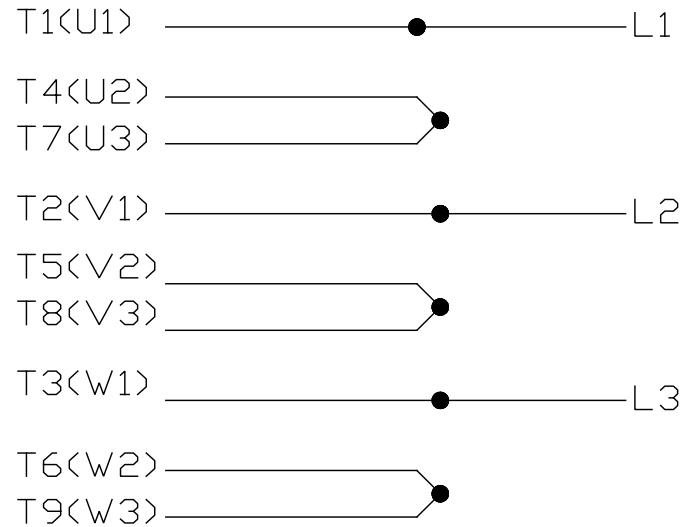

VIEW OF TERMINAL END

			TOLERANCES UNLESS SPECIFIED		 REGAL - BELOIT CORPORATION	DRAWN PGK 06-04-1997					
NO.	REVISION	BY & DATE	CHK	ANG		±	INCHES	SCALE	PREV		
E	CORRECTED IEC MARKINGS ECD-0111208	WGJ 01-23-2017	EMH	DEC.				CHK ML 06-05-1997			
D	RE-DRAWN WITH REGAL LOGO ECD-0110493	WGJ 09-30-2016	EMH	.X	±.1			APPD GK 06-15-1997			
8	ADDED IEC DESIGNATIONS MU95020	TJW 4/30/2010	MJS	.XX	±.02		TITLE CONNECTION DIAGRAM				
7	REVISED HIGH VOLTAGE L2 WAS L3 CN52600-354	MRB 09-21-1998		.XXX	±.005		TITLE DELTA CON. - 3Ø - 9 LEADS	REF			
6	REDRAWN ON CADD	PGK 06-05-1997		.XXXX	±.0005		MAT'L.	FMF			
					±7'30"		FINISH				
THIS DRAWING IN DESIGN AND DETAIL IS OUR PROPERTY AND MUST NOT BE USED EXCEPT IN CONNECTION WITH OUR WORK ALL RIGHTS OF DESIGN AND INVENTION ARE RESERVED THIS IS AN ELECTRONICALLY GENERATED DOCUMENT - DO NOT SCALE THIS PRINT					RFP	CAD FILE EE7308K		SIZE A	DRAWING NO. EE7308K	PAGE OF	REV. E
					DIST						