

PRODUCT INFORMATION PACKET

Model No: 326TSTDR16034

Catalog No: E791A

XRI® General Purpose General Purpose Motor, 50 & 40 HP, 3 Ph, 60 & 50 Hz, 230/460 & 190/380 V,
1800 & 1500 RPM, 326TS Frame, DP



Regal and Marathon are trademarks of Regal Rexnord Corporation or one of its affiliated companies.

©2023 Regal Rexnord Corporation, All Rights Reserved. MC017097E

Nameplate Specifications

Phase	3	Output HP	50 & 40 Hp
Output KW	37.0 & 30.0 kW	Voltage	230/460 & 190/380 V
Speed	1775 & 1470 rpm	Service Factor	1.15 & 1.15
Frame	326TS	Enclosure	Drip Proof
Thermal Protection	No Protection	Efficiency	94.5 & 94.1 %
Ambient Temperature	40 °C	Frequency	60 & 50 Hz
Current	121/60.5 & 116/58 A	Power Factor	82
Duty	Continuous	Insulation Class	B
Design Code	B	KVA Code	G
Drive End Bearing Size	6312	Opp Drive End Bearing Size	6311
UL	Recognized	CSA	Y
CE	Y	IP Code	22
Number of Speeds	1		

Technical Specifications

Electrical Type	Squirrel Cage Induction Run	Starting Method	Across The Line
Poles	4	Rotation	Reversible
Resistance Main	.027 Ohms	Mounting	Rigid Base
Motor Orientation	Horizontal	Drive End Bearing	Ball
Opp Drive End Bearing	Ball	Frame Material	Rolled Steel
Shaft Type	TS	Overall Length	27.09 in
Frame Length	15.00 in	Shaft Diameter	1.875 in
Shaft Extension	4 in	Assembly/Box Mounting	F1 ONLY
Connection Drawing	A-EE7308K	Outline Drawing	A-SS28288-1500

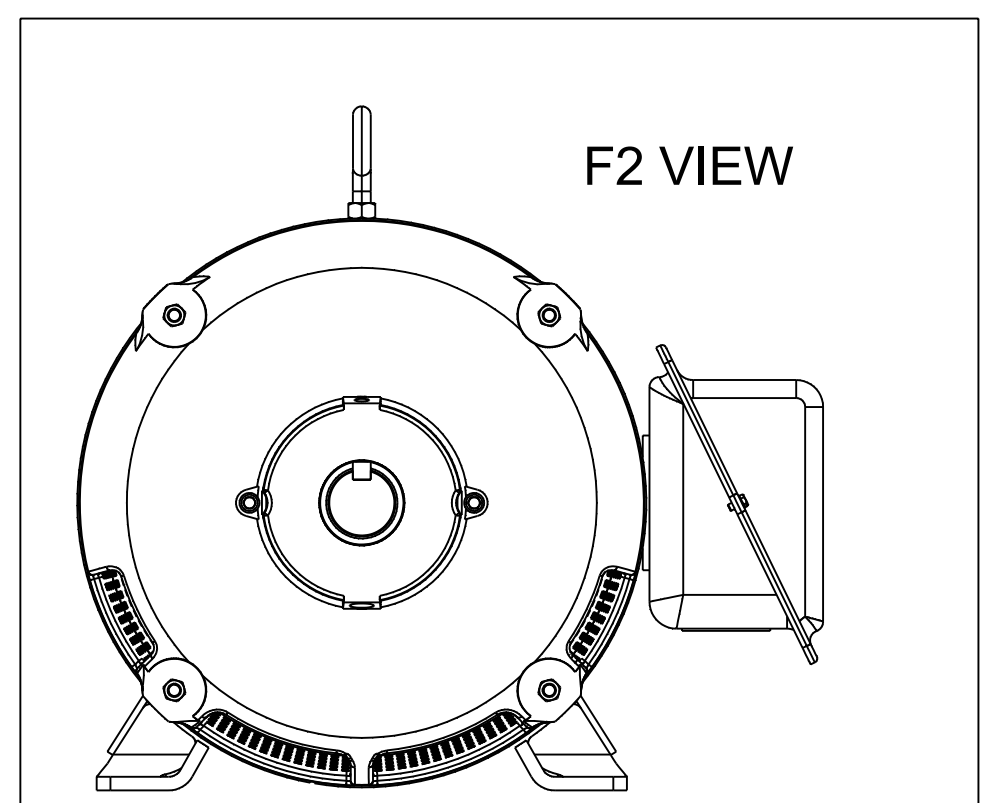
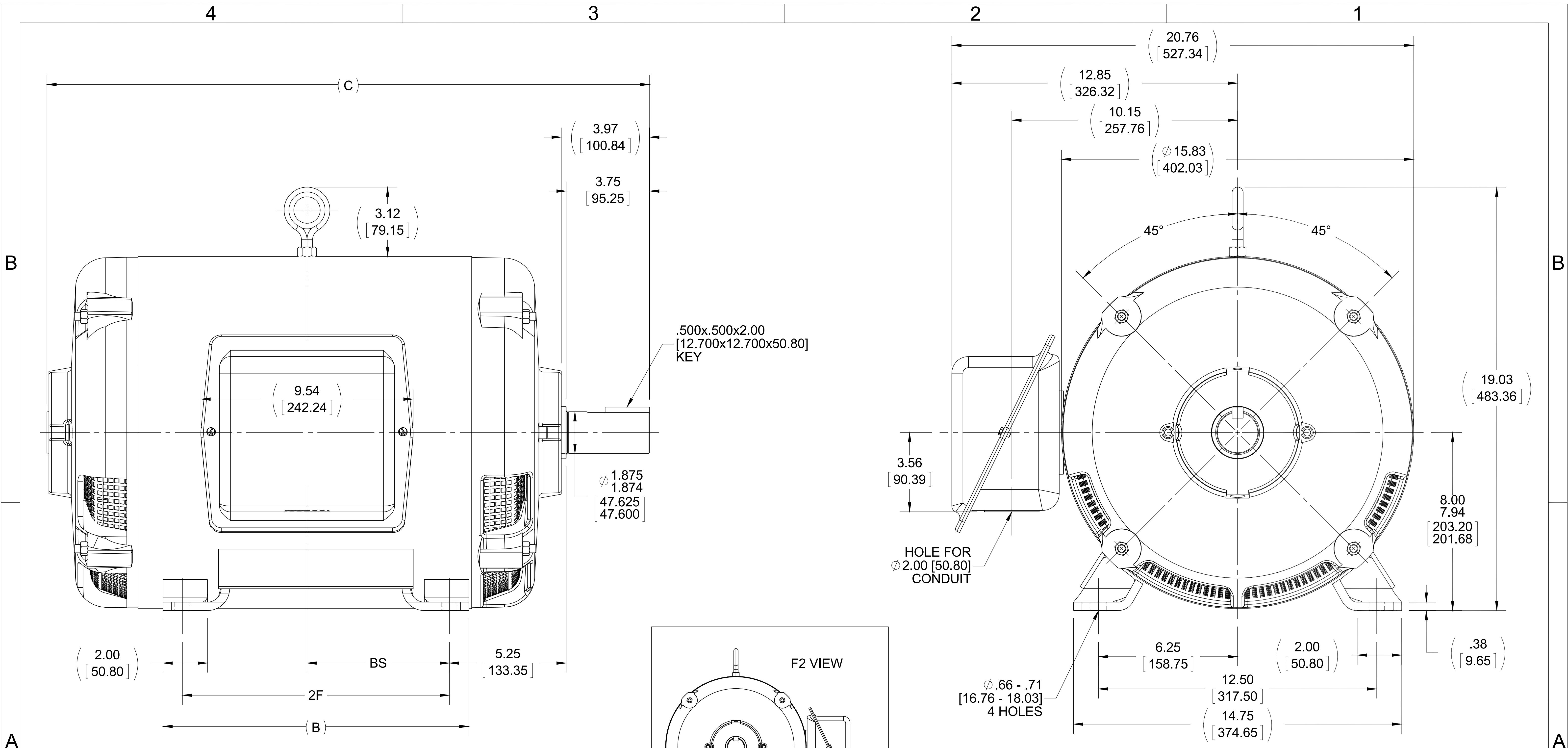

- NOTES:
 1. CONDUIT BOX CAN BE ROTATED IN 90° STEPS.
 2. CONDUIT BOX CAN BE MOUNTED ON OPPOSITE SIDE BY REMOVING BRACKETS AND TURNING FRAME 180°.
 3. NAMEPLATE READ FROM CONDUIT BOX SIDE OF MOTOR.

DASH 1750 HAS A SPECIAL CONDUIT BOX LOCATION

1250	324TS	24.59 [624.59]	12.25 [311.15]	10.50 [266.70]	5.25 [133.35]	F1 OR F2
1400	326TS	26.09 [662.69]	13.75 [349.25]	12.00 [304.80]	6.00 [152.40]	F1 OR F2
1400	324TS	26.09 [662.69]	12.25 [311.15]	10.50 [266.70]	6.00 [152.40]	F1 ONLY
1450	324TS	26.59 [675.39]	12.25 [311.15]	10.50 [266.70]	6.25 [158.75]	F1 ONLY
1500	326TS	27.09 [688.09]	13.75 [349.25]	12.00 [304.80]	6.40 [162.56]	F1 ONLY
1750	326TS	29.59 [751.59]	13.75 [349.25]	12.00 [304.80]	9.10 [231.14]	F1 ONLY
DASH	FRAME	C	B	2F	BS	MTG.

DRAWING REVISION H	REVISION BY MSG	DATE 11-16-2015
ECO ECO-0088777	APPROVED BY TVUE	DATE 11-17-2015
ECO DESCRIPTION UPDATE TO CURRENT STANDARDS		
<small>COPYRIGHT REGAL BELOIT AMERICA, INC. ALL RIGHTS RESERVED. PROPRIETARY AND CONFIDENTIAL INFORMATION - THIS DOCUMENT IS THE PROPERTY OF REGAL BELOIT AMERICA, INC. ("OWNER") AND CONTAINS OWNER'S PROPRIETARY INFORMATION. ANY PERSON, CORPORATION OR OTHER FIRM RECEIVING IT IS DEEMED, BY RECEIVING IT, TO AGREE THAT IT, AND/OR ANY PART OF IT, SHALL NOT BE DISCLOSED TO ANY PERSON, CORPORATION OR OTHER ENTITY, DUPLICATED, AND/OR USED, EXCEPT AS EXPRESSLY APPROVED IN WRITING IN ADVANCE BY OWNER. THIS DOCUMENT SHALL BE RETURNED TO OWNER UPON REQUEST. IT MAY BE SUBJECT TO CERTAIN RESTRICTIONS UNDER APPLICABLE EXPORT CONTROL LAWS AND REGULATIONS.</small>		

TOLERANCES UNLESS OTHERWISE SPECIFIED:			
DEC.	INCH	mm	ANGLE
.X	±0.1	[±2.5]	±7° 30"
.XX	±0.03	[±0.76]	
.XXX	±0.005	[±0.127]	
.XXXX	±0.0005	[±0.0127]	
REMOVE BURRS & BREAK SHARP EDGES: .003/.015 [0.076/.381] X 45° CORNER FILLETS: R.02 [51]			
MACHINED SURFACES: 200 INCH/mm 5.1			
mm SHOWN IN [BRACKETS]			

DRAWN BY TJB
DATE 11-19-1999
APPROVED BY ML
DATE 11-19-1999
REFERENCE
THIRD ANGLE PROJECTION

REGAL ™ Regal Beloit America, Inc.	
DESCRIPTION OUTLINE 320TS FR. - DR. PR. BB - TS	
MATERIAL	PROCESS/FINISH
SIZE B	DRAWING NUMBER SS28288
SHEET 1 OF 1	

LOW VOLTAGE



HIGH VOLTAGE

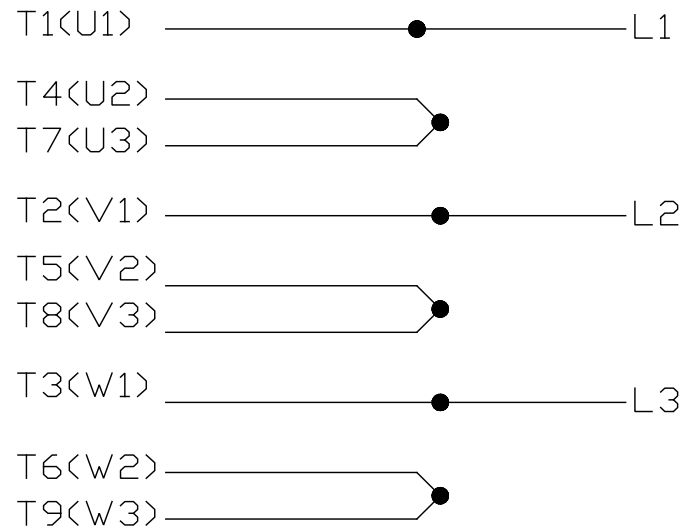

VIEW OF TERMINAL END

				TOLERANCES UNLESS SPECIFIED		 REGAL - BELOIT CORPORATION	DRAWN PGK 06-04-1997						
NO.	REVISION	BY & DATE	CHK	ANG	±		UNIT	CHK	ML 06-05-1997				
E	CORRECTED IEC MARKINGS	ECO-0111208	WGJ	01-23-2017	EMH	DEC.	INCHES	APPD	GK 06-15-1997				
D	RE-DRAWN WITH REGAL LOGO	ECO-0110493	WGJ	09-30-2016	EMH	.X	±.1						
8	ADDED IEC DESIGNATIONS	MU95020	TJW	4/30/2010	MJS	.XX	±.02	TITLE CONNECTION DIAGRAM					
7	REVISED HIGH VOLTAGE L2 WAS L3	CN52600-354	MRB	09-21-1998		.XXX	±.005	SCALE					
6	REDRAWN ON CADD		PGK	06-05-1997		.XXXX	±.0005	REF					
								MAT'L.					
								FINISH					
THIS DRAWING IN DESIGN AND DETAIL IS OUR PROPERTY AND MUST NOT BE USED EXCEPT IN CONNECTION WITH OUR WORK ALL RIGHTS OF DESIGN AND INVENTION ARE RESERVED THIS IS AN ELECTRONICALLY GENERATED DOCUMENT - DO NOT SCALE THIS PRINT						RFP	CAD FILE EE7308K		SIZE	DRAWING NO.	PAGE	OF	REV.
						DIST			A	EE7308K			E

CERTIFICATION DATA SHEET

Model#: 326TSTDR16034 AN **WINDING#:** 3264160 NONE 1
CONN. DIAGRAM: A-EE7308K **ASSEMBLY:** F1/F2 CAPABLE
OUTLINE: A-SS28288-1500

TYPICAL MOTOR PERFORMANCE DATA

HP	KW	SYNC. RPM	F.L. RPM	FRAME	ENCLOSURE	KVA CODE	DESIGN
50&40	37&30	1800	1775&1470	326TS	DP	G	B

PH	Hz	VOLTS	FL AMPS	START TYPE	DUTY	INSL	S.F	AMB°C	ELEVATION
3	60/50	230/460#190/ 380	121/60.5&116/ 58	ACROSS THE LINE	CONTINUOU S	B3	1.15/1.15	40	3300

FULL LOAD EFF: 94.5&94.1	3/4 LOAD EFF: 94.5	1/2 LOAD EFF: 93.6	GTD. EFF	ELEC. TYPE	NO LOAD AMPS
FULL LOAD PF: 82&82.5	3/4 LOAD PF: 79	1/2 LOAD PF: 70	94.1	SQ CAGE IND RUN	46 / 23

F.L. TORQUE	LOCKED ROTOR AMPS	L.R. TORQUE	B.D. TORQUE	F.L. RISE°C
148 LB-FT	716 / 358	283 LB-FT 191	387 LB-FT 261	50

SOUND PRESSURE @ 3 FT.	SOUND POWER	ROTOR WK^2	MAX. WK^2	SAFE STALL TIME	STARTS /HOUR	APPROX. MOTOR WGT
75 dBA	85 dBA	8.8 LB-FT^2	300 LB-FT^2	20 SEC.	2	615 LBS.

***** SUPPLEMENTAL INFORMATION *****

DE BRACKET TYPE	ODE BRACKET TYPE	MOUNT TYPE	ORIENTATION	SEVERE DUTY	HAZARDOUS LOCATION	DRIP COVER	SCREENS	PAINT
STANDARD	STANDARD	RIGID	HORIZONTAL	FALSE	NONE	FALSE	NONE	BLUE (ENAMEL)

BEARINGS		GREASE	SHAFT TYPE	SPECIAL DE	SPECIAL ODE	SHAFT MATERIAL	FRAME MATERIAL
DE	OPE						
BALL	BALL	POLYREX EM	TS	NONE	NONE	1045 HOT ROLLED (C-204)	ROLLED STEEL
6312	6311						

THERMO-PROTECTORS				THERMISTORS	CONTROL	SPACE /n HEATERS
THERMOSTATS	PROTECTORS	WDG RTDs	BRG RTDs			
NONE	NOT	NONE	NONE	NONE	FALSE	NONE VOLTS

If Inverter equals NONE, contact factory for further information

INVERTER TORQUE: NONE
INV. HP SPEED RANGE: NONE
ENCODER: NONE
NONE NONE
NONE NONE PPR
BRAKE: NONE NONE
NONE P/N NONE
NONE NONE
- FT-LB NONE V NONE Hz

*
N
O
T
E
S
*

DATE: 06/21/2017 06:06:56 AM
 FORM 3531 REV.3 02/07/99
 ** Subject to change without notice.

Data Sheet

Date: 6/29/2017

326TSTDR16034

Customer: _____



Attention: _____

Submittal

Submitted by: FAREEDA DUDEKULA

Data @ 460 V

Motor Load Data

Load	0%	25%	50%	75%	100%	115%	125%	LR
Current (Amps)	23.0	27.0	36.0	47.5	60.5	69.0	75.0	358
Torque (ft-lb)	0.00	36.5	73.5	111	148	171	186	283
RPM	1800	1795	1790	1780	1775	1,773	1770	0
Efficiency (%)		91.0	93.6	94.5	94.5	94.1	93.6	
P.F. (%)	4.5	48.5	70.0	79.0	82.0	83.0	83.2	34.5

Motor Speed Data

	LR	Pull-Up	BD	Rated	Idle
Speed (RPM)	0	900	1700	1775	1800
Current (Amps)	358	305	198	60.5	23.0
Torque (ft-lb)	283	240	387	148	0.00

Information Block

HP	50.0
Sync. RPM	1800
Frame	326
Enclosure	DP
Construction	TDR
Voltage	30/460#190/381V
Frequency	60 Hz
Design	B
LR Code letter	G
Service Factor	1.15
Temp Rise @ FL	50 °C
Duty	CONT
Ambient	40 °C
Elevation	1,000 feet
Rotor/Shaft wk ²	8.8 Lb-Ft ²
Ref Wdg	3264160 NONE
Sound Pressure @ 1M	75 dBA
VFD Rating	NONE
Outline Dwg	A-SS28288-1500
Conn. Diag	A-EE7308K

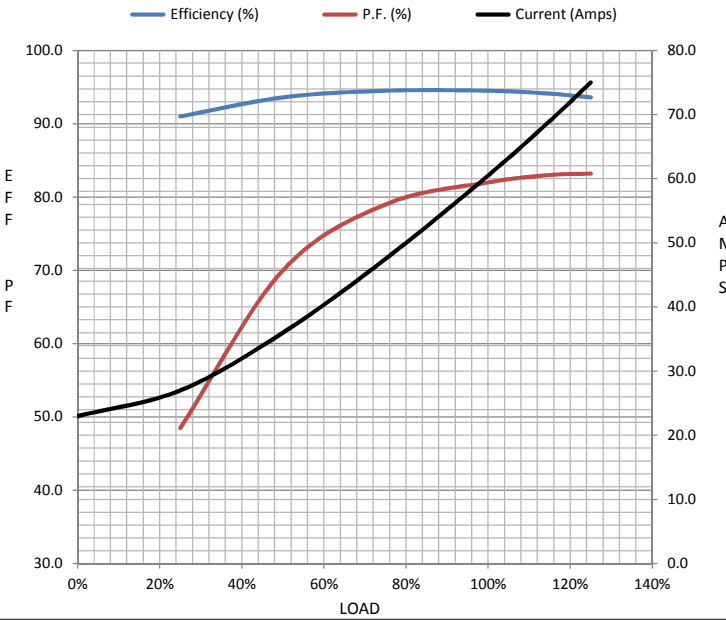

Additional Specifications:

0

0

EQUIV CKT (OHMS / PHASE)

R1	R2	X1	X2	Xm
0.0780	0.0650	0.5140	0.6420	10.9620

Speed -Torque Curve

