

PRODUCT INFORMATION PACKET

Model No: 326TSTDP4022

Catalog No: U517

60 HP Fire Pump Motor, 3 phase, 3600 RPM, 200/400 V, 326TS Frame, ODP
Fire Pump Motors

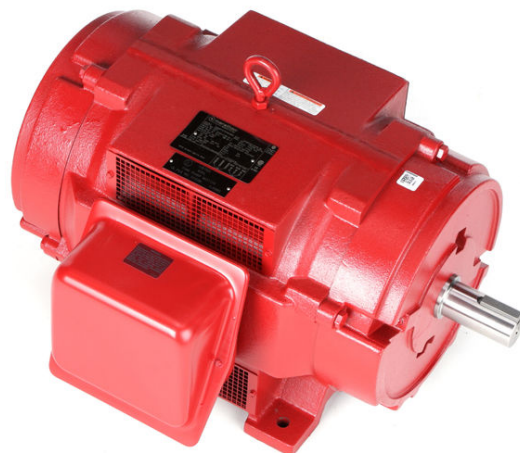

Regal and Marathon are trademarks of Regal Rexnord Corporation or one of its affiliated companies.
©2021 Regal Rexnord Corporation, All Rights Reserved. MC017097E



Nameplate Specifications

Output HP	60 Hp	Output KW	45.0 kW
Frequency	60 Hz	Voltage	200/400 V
Current	155.0/77.5 A	Speed	3555 rpm
Service Factor	1.15	Phase	3
Efficiency	93 %	Power Factor	89
Duty	Continuous	Insulation Class	F
Design Code	B	KVA Code	G
Frame	326TS	Enclosure	Drip Proof
Thermal Protection	No	Ambient Temperature	50 °C
Drive End Bearing Size	6312	Opp Drive End Bearing Size	6311
UL	No	CSA	Y
CE	Y	IP Code	23
Number of Speeds	1		

Technical Specifications

Electrical Type	Squirrel Cage Induction Run	Starting Method	Part Wdg Start Low Volt Only & Wye Start Delta Run
Poles	2	Rotation	Reversible
Resistance Main	.14 Ohms	Mounting	Rigid Base
Motor Orientation	Horizontal	Drive End Bearing	Ball
Opp Drive End Bearing	Ball	Frame Material	Cast Iron
Shaft Type	TS	Overall Length	26.00 in
Frame Length	15.12 in	Shaft Diameter	1.875 in
Shaft Extension	4.02 in	Assembly/Box Mounting	F1/F2 Capable
Connection Drawing	A-EE7358	Outline Drawing	B-SS200079A-1512

This is an uncontrolled document once printed or downloaded and is subject to change without notice. Date Created:10/12/2021

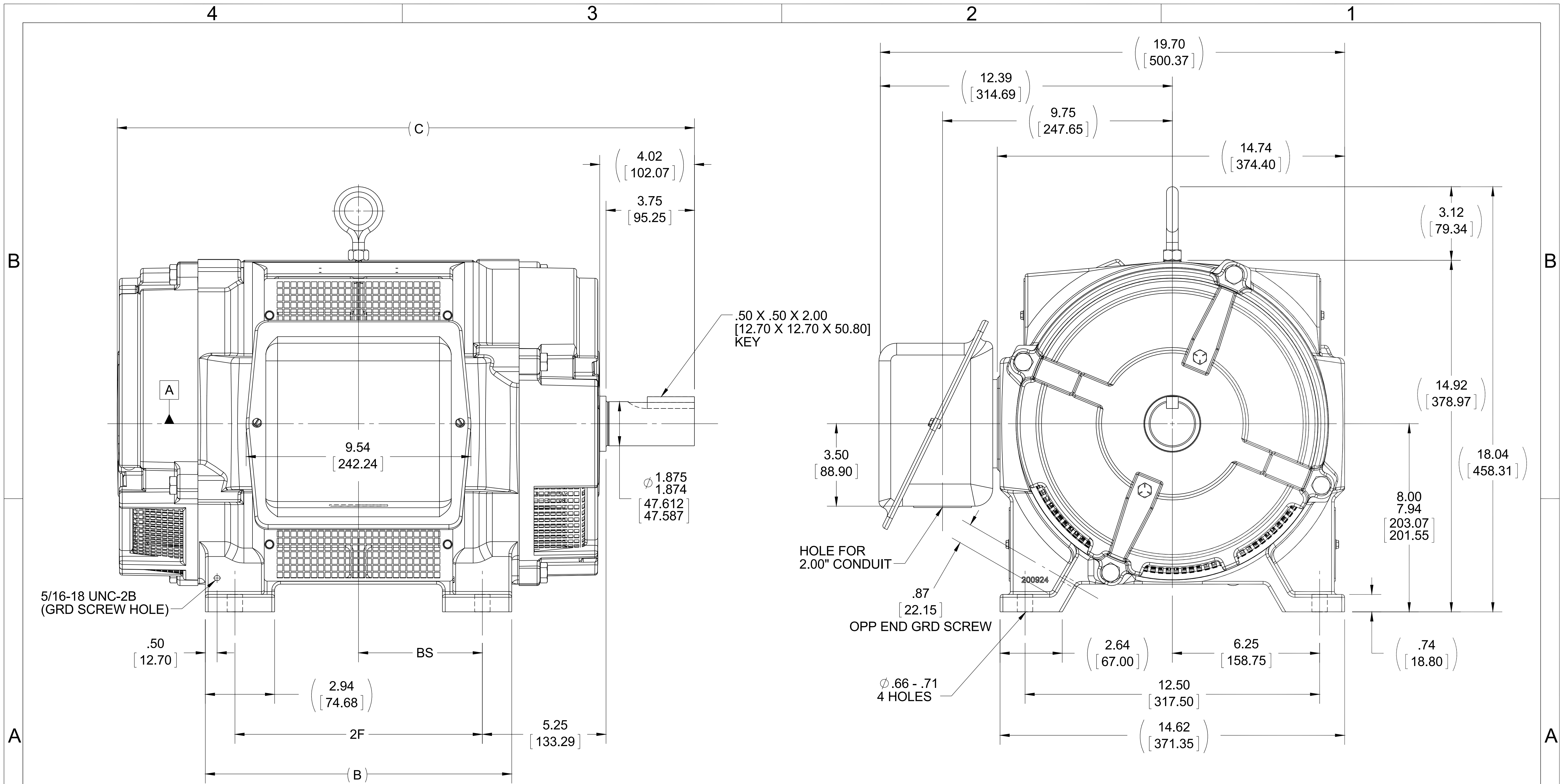

.50 X .50 X 2.00
[12.70 X 12.70 X 50.80]
KEY

Ø 1.875
1.874
[47.612
47.587]

HOLE FOR
2.00" CONDUIT

.87
[22.15]
OPP END GRD SCREW

Ø .66 - .71
4 HOLES

5/16-18 UNC-2B
(GRD SCREW HOLE)

- NOTES:
1. CONDUIT BOX CAN BE ROTATED IN 90° STEPS
 2. CONDUIT BOX CAN BE MOUNTED ON OPPOSITE SIDE BY REMOVING BRACKETS AND TURNING FRAME 180°
 3. NAMEPLATE TO BE READ FROM CONDUIT BOX SIDE OF MOTOR

DASH	FRAME	B	C	2F	BS
1362	324TS	13.00 [330.20]	24.50 [622.30]	10.50 [266.70]	5.25 [133.35]
1512	326TS	14.50 [368.30]	26.00 [660.40]	12.00 [304.80]	6.00 [152.40]

DRAWING REVISION B	REVISION BY W. JOERGER	DATE 11-11-2015
ECO ECO-0088742	APPROVED BY E. HEIL	DATE 11-11-2015
ECO DESCRIPTION REMOVED C-FACE BOLT CIRCLE DIMENSION		
<small>COPYRIGHT REGAL BELOIT AMERICA, INC. ALL RIGHTS RESERVED. PROPRIETARY AND CONFIDENTIAL INFORMATION - THIS DOCUMENT IS THE PROPERTY OF REGAL BELOIT AMERICA, INC. ("OWNER") AND CONTAINS OWNER'S PROPRIETARY INFORMATION. ANY PERSON, CORPORATION OR OTHER FIRM RECEIVING IT IS DEEMED, BY RECEIVING IT, TO AGREE THAT IT, AND/OR ANY PART OF IT, SHALL NOT BE DISCLOSED TO ANY PERSON, CORPORATION OR OTHER ENTITY, DUPLICATED, AND/OR USED, EXCEPT AS EXPRESSLY APPROVED IN WRITING IN ADVANCE BY OWNER. THIS DOCUMENT SHALL BE RETURNED TO OWNER UPON REQUEST. IT MAY BE SUBJECT TO CERTAIN RESTRICTIONS UNDER APPLICABLE EXPORT CONTROL LAWS AND REGULATIONS.</small>		

TOLERANCES UNLESS OTHERWISE SPECIFIED:

DEC.	INCH	mm	ANGLE
.X	±0.1	[±2.5]	±7° 30"
.XX	±0.03	[±0.76]	
.XXX	±0.005	[±0.127]	
.XXXX	±0.0005	[±0.0127]	

REMOVE BURRS & BREAK SHARP EDGES: .003/.015 [0.076/.381] X 45°
CORNER FILLETS: R.02 [0.51]
MACHINED SURFACES: 200 INCH 5.1 mm
mm SHOWN IN [BRACKETS]

DRAWN BY W. JOERGER
DATE 10-29-2015
APPROVED BY E. HEIL
DATE 10-29-2015
REFERENCE
THIRD ANGLE PROJECTION

REGAL ™ Regal Beloit America, Inc.	
DESCRIPTION OUTLINE	
DR PR - CAST IRON - 320TS FR - BB - TS - D.E.V.	
MATERIAL	PROCESS/FINISH
SIZE B	DRAWING NUMBER SS200079A
	SHEET 1 OF 1

HIGH VOLTAGE

WYE START

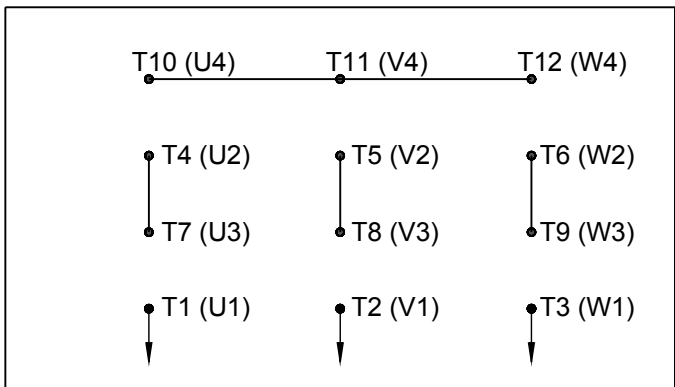

DELTA RUN

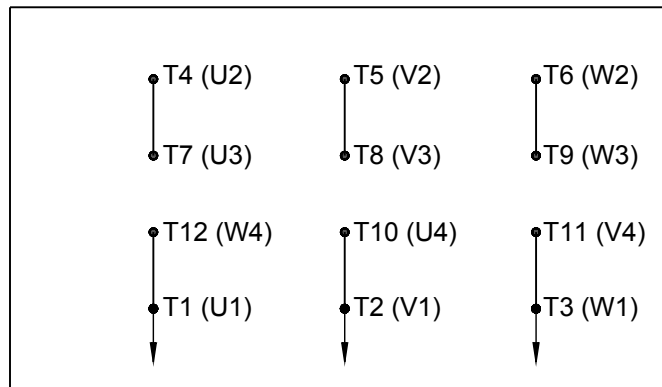

WYE START

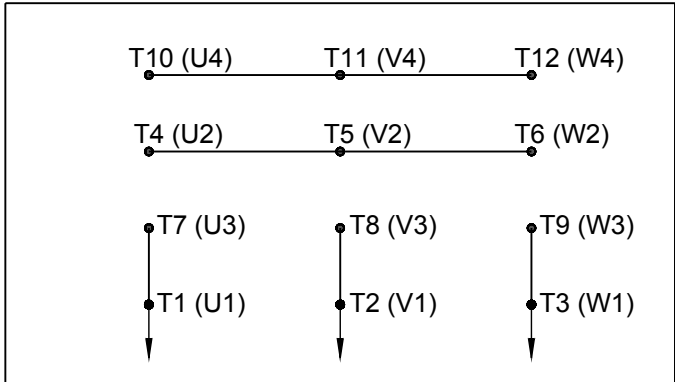

LOW VOLTAGE

DELTA RUN

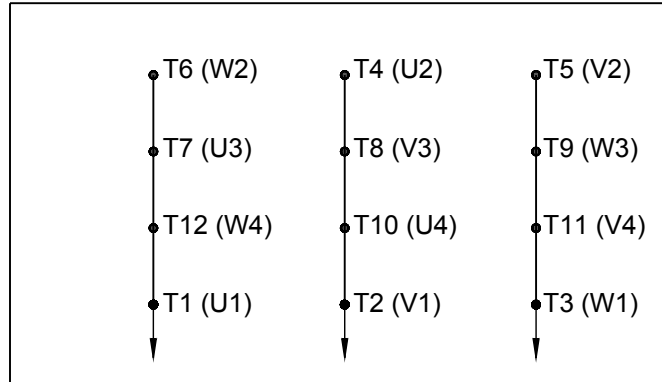

4/2 CKTY \triangle

DRAWING REVISION D	REVISION BY JWO	DATE 01-26-2016
ECO ECO-0092547	APPROVED BY TB	DATE 01-26-2016

ECO DESCRIPTION
ADDED IEC MARKINGS

COPYRIGHT REGAL BELOIT AMERICA, INC. ALL RIGHTS RESERVED. PROPRIETARY AND CONFIDENTIAL INFORMATION - THIS DOCUMENT IS THE PROPERTY OF REGAL BELOIT AMERICA, INC. ("OWNER") AND CONTAINS OWNER'S PROPRIETARY INFORMATION. ANY PERSON, CORPORATION OR OTHER FIRM RECEIVING IT IS DEEMED, BY RECEIVING IT, TO AGREE THAT IT, AND/OR ANY PART OF IT, SHALL NOT BE DISCLOSED TO ANY PERSON, CORPORATION OR OTHER ENTITY, DUPLICATED, AND/OR USED, EXCEPT AS EXPRESSLY APPROVED IN WRITING IN ADVANCE BY OWNER. THIS DOCUMENT SHALL BE RETURNED TO OWNER UPON REQUEST. IT MAY BE SUBJECT TO CERTAIN RESTRICTIONS UNDER APPLICABLE EXPORT CONTROL LAWS AND REGULATIONS.

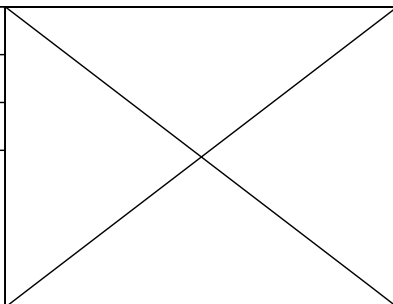

DRAWN BY BLR		Regal Beloit America, Inc.
DATE 03-09-1998		
APPROVED BY GK	DESCRIPTION CONN DIAGRAM-EXTERNAL	
DATE 03-23-1998	12 LEAD - DUAL VOLT. - WYE START - DELTA RUN	
REFERENCE	MATERIAL	PROCESS/FINISH
THIRD ANGLE PROJECTION	SIZE A	DRAWING NUMBER EE7358

SHEET 1 OF 1	
-----------------	--

CERTIFICATION DATA SHEET

Model#: 326TSTDP4022 BC
CONN. DIAGRAM: A-EE7358
OUTLINE: B-SS200079A-1512

WINDING#: K2862124 NONE 8
ASSEMBLY: F1/F2 CAPABLE

TYPICAL MOTOR PERFORMANCE DATA

HP	KW	SYNC. RPM	F.L. RPM	FRAME	ENCLOSURE	KVA CODE	DESIGN
60	45	3600	3555	326TS	DP	G	B

PH	Hz	VOLTS	FL AMPS	START TYPE	DUTY	INSL	S.F	AMB°C	ELEVATION
3	60	200/400	155/77.5	PWS(LV ONLY) & YDRUN	CONTINUOUS	F3	1.15	50	3300

FULL LOAD EFF: 93	3/4 LOAD EFF: 93.6	1/2 LOAD EFF: 93.6	GTD. EFF	ELEC. TYPE	NO LOAD AMPS
FULL LOAD PF: 89	3/4 LOAD PF: 87	1/2 LOAD PF: 81	91.7	SQ CAGE IND RUN	43.7 / 21.9

F.L. TORQUE	LOCKED ROTOR AMPS	L.R. TORQUE	B.D. TORQUE	F.L. RISE°C
88.5 LB-FT	977.5 / 488.8	130 LB-FT 147	240 LB-FT 271	40

SOUND PRESSURE @ 3 FT.	SOUND POWER	ROTOR WK^2	MAX. WK^2	SAFE STALL TIME	STARTS / HOUR	APPROX. MOTOR WGT
82 dBA	92 dBA	3.3 LB-FT^2	44 LB-FT^2	15 SEC.	2	475 LBS.

***** SUPPLEMENTAL INFORMATION *****

DE BRACKET TYPE	ODE BRACKET TYPE	MOUNT TYPE	ORIENTATION	SEVERE DUTY	HAZARDOUS LOCATION	DRIP COVER	SCREENS	PAINT
STANDARD	STANDARD	RIGID	HORIZONTAL	FALSE	NONE	FALSE	RODENT	RED (ENAMEL)

BEARINGS		GREASE	SHAFT TYPE	SPECIAL DE	SPECIAL ODE	SHAFT MATERIAL	FRAME MATERIAL
DE	OPE						
BALL	BALL	POLYREX EM	TS	NONE	NONE	1045 HOT ROLLED (C-204)	CAST IRON
6312	6311						

THERMO-PROTECTORS				THERMISTORS	CONTROL	SPACE /n HEATERS
THERMOSTATS	PROTECTORS	WDG RTDs	BRG RTDs			
NONE	NOT	NONE	NONE	NONE	FALSE	NONE VOLTS

If Inverter equals NONE, contact factory for further information

*
N
O
T
E
S
*

INVERTER TORQUE: NONE
INV. HP SPEED RANGE: NONE
ENCODER: NONE
NONE NONE
NONE NONE PPR
BRAKE: NONE NONE
NONE P/N NONE
NONE NONE
NONE FT-LB NONE V NONE Hz

DATE: 06/21/2017 06:05:21 AM
 FORM 3531 REV.3 02/07/99

** Subject to change without notice.

Data Sheet

Date: 6/19/2017

326TSTDP4022

Customer: _____

Attention: _____

Submitted by: FAREEDA DUDEKULA



Submittal

Data @ 400 V

Motor Load Data

Load	0%	25%	50%	75%	100%	115%	125%	LR
Current (Amps)	21.9	28.8	42.6	59.8	77.6	89.1	97.8	489
Torque (ft-lb)	0.00	22.0	44.0	66.5	88.5	102	112	130
RPM	3600	3590	3575	3565	3555	3,545	3535	0
Efficiency (%)		91.0	93.6	93.6	93.0	93.0	92.4	
P.F. (%)	6.5	62.0	81.0	87.0	89.0	89.5	89.5	34.0

Motor Speed Data

	LR	Pull-Up	BD	Rated	Idle
Speed (RPM)	0	1500	3300	3555	3600
Current (Amps)	489	460	316	77.6	21.9
Torque (ft-lb)	130	115	240	88.5	0.00

Information Block

HP	60.0			
Sync. RPM	3600			
Frame	326			
Enclosure	DP			
Construction	TDP			
Voltage	200/400 V			
Frequency	60 Hz			
Design	A			
LR Code letter	G			
Service Factor	1.15			
Temp Rise @ FL	40 °C			
Duty	CONT			
Ambient	40 °C			
Elevation	1,000 feet			
Rotor/Shaft wk ²	3.3 Lb-Ft ²			
Ref Wdg	K2862124 NONE			
Sound Pressure @ 1M	82 dBA			
VFD Rating	NONE			
Outline Dwg	B-SS200079A-1512			
Conn. Diag	A-EE7358			
Additional Specifications:				
0				
0				
EQUIV CKT (OHMS / PHASE)				
R1	R2	X1	X2	Xm
0.0600	0.0370	0.2900	0.2340	10.2220

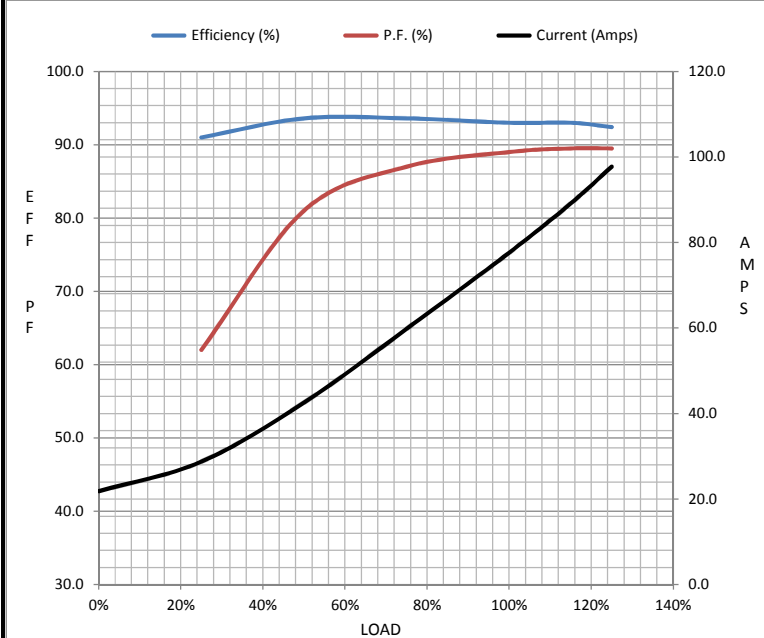

Speed -Torque Curve

