

PRODUCT INFORMATION PACKET

marathon®
Motors

Model No: 324TTGP1026

Catalog No: U963

Explosion Proof Motor, 40 & 30 HP, 3 Ph, 60 & 50 Hz, 230/460 & 190/380 V, 1800 & 1500 RPM,
324T Frame, EPFC



Regal and Marathon are trademarks of Regal Rexnord Corporation or one of its affiliated companies.

©2023 Regal Rexnord Corporation, All Rights Reserved. MC017097E

RegalRexnord

Nameplate Specifications

Phase	3	Output HP	40 & 30 Hp
Output KW	30.0 & 22.4 kW	Voltage	230/460 & 190/380 V
Speed	1762 & 1470 rpm	Service Factor	1.15 & 1.15
Frame	324T	Enclosure	Explosion Proof Fan cooled
Thermal Protection	No Protection	Efficiency	93 & 93.6 %
Ambient Temperature	40 °C	Frequency	60 & 50 Hz
Current	100/50 & 91/45.5 A	Power Factor	81
Duty	Continuous	Insulation Class	F
Design Code	B	KVA Code	G
Drive End Bearing Size	6312	Opp Drive End Bearing Size	6311
UL	UL Listed And CSA Certified	CSA	Y
CE	N	IP Code	54
Number of Speeds	1	Hazardous Location	EXP PROOF CL I GR C&D T2A

Technical Specifications

Electrical Type	Squirrel Cage Induction Run	Starting Method	Across The Line
Poles	4	Rotation	Reversible
Resistance Main	.165 Ohms	Mounting	Rigid Base
Motor Orientation	Horizontal	Drive End Bearing	Ball
Opp Drive End Bearing	Ball	Frame Material	Cast Iron
Shaft Type	T	Overall Length	28.97 in
Frame Length	14.75 in	Shaft Diameter	2.125 in
Shaft Extension	5.25 in	Assembly/Box Mounting	F1 ONLY
Connection Drawing	A-EE7308	Outline Drawing	B-SS311001-1475

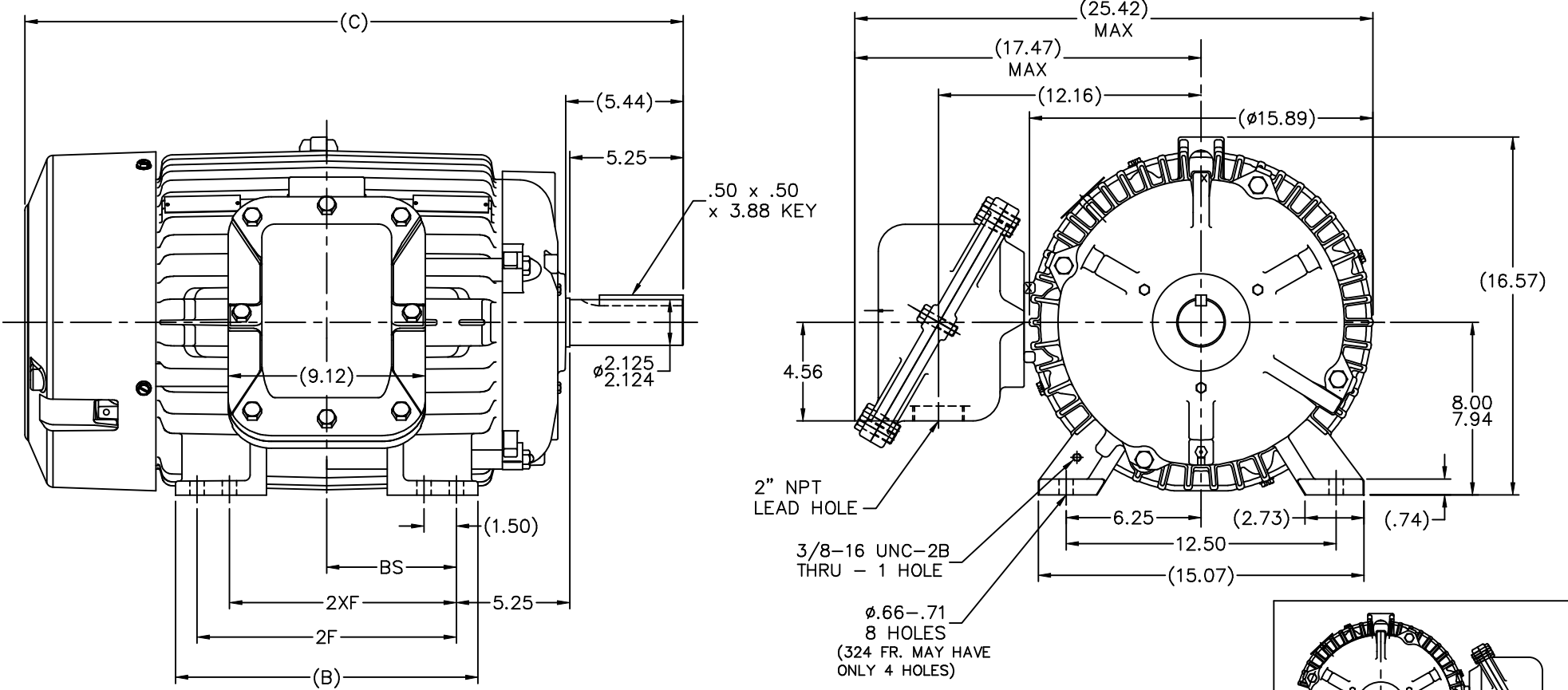

NOTES:
 1. BOX CAN ONLY BE ROTATED CLOCKWISE UP TO 270° FROM ITS ORIGINAL POSITION.
 2. NAMEPLATE TO BE READ FROM CONDUIT BOX SIDE OF MOTOR.

DASH	FRAME	B	C	2F	2XF	BS
1475	324T	14.00	28.97	10.50		5.25
1625	324/326T	14.00	30.47	12.00	10.50	6.00

		TOLERANCES UNLESS SPECIFIED		MARATHON ELECTRIC		DRAWN DA 03-25-1999	
NO.	REVISION	BY & DATE	CHK	ANG	FINISH	PREV	
7	REDRAWN IN AUTOCAD	TAT 06-28-2004	ML	.X	±.1		CHK ML 04-14-1989
6	FRAME FOR 1625 DASH WAS 326T FR. MU38599	TJB 08-23-2001		.XX	±.03		APPD SW 04-14-1999
5	DASH 1475 'B' WAS 12.50 CN 29200-1468	MSG 02-21-2001		.XXX	±.005		SCALE 7-32
4	ADDED F2 VIEW CN 29200-383	TJB 04-28-2000		.XXXX	±.0005		REF
							FMF
							PREV
THIS DRAWING IN DESIGN AND DETAIL IS OUR PROPERTY AND MUST NOT BE USED EXCEPT IN CONNECTION WITH OUR WORK ALL RIGHTS OF DESIGN AND INVENTION ARE RESERVED THIS IS AN ELECTRONICALLY GENERATED DOCUMENT - DO NOT SCALE THIS PRINT						RFP	CAD FILE ss311001
						DIST LB	SIZE B DRAWING NO. SS311001 PAGE OF 7

EE7308

THREE PHASE
DUAL VOLTAGE MOTOR



VIEW OF TERMINAL END

REF.
WINDING DIAGRAM

T8Y, T2Y, T2BL, T4BX, T2EC, T2G
T6BZ, T2B, T6BL, T4AV, T6B, T4B

OPTIONAL CORD
CONNECTION

L1 — WHITE
L2 — RED
L3 — BLACK

NO.	REVISION	BY & DATE	CHK	ANG	TOLERANCES UNLESS SPECIFIED		FINISH	DRAWN RM 11/20/1990				
					DEC.	INCHES						
5	CHG TO REGAL LOGO	SL 09/10/2015	AB					CHK ML 11/21/1990				
4	REVISED IEC NOTATIONS	MSG 11/15/2011	CMN	.X	±.1			APPD SAS 04/24/2003				
3	ADDED IEC NOTATIONS... (U1), (V1) ETC. MU95194	MSG 5/10/2010	MJS	.XX	±.02		TITLE CONNECTION DIAGRAM	SCALE 1=1				
2	ADDED THE OPTIONAL CORD CONNECTION MU46318	RDH 04/24/2003	DRS	.XXX	±.005		3Ø - DUAL VOLTAGE MOTOR	REF				
1	REDRAWN	RM 11/20/1990		.XXXX	±.0005		MAT'L.	FMF				
					±7'30"			PREV				
THIS DRAWING IN DESIGN AND DETAIL IS OUR PROPERTY AND MUST NOT BE USED EXCEPT IN CONNECTION WITH OUR WORK ALL RIGHTS OF DESIGN AND INVENTION ARE RESERVED THIS IS AN ELECTRONICALLY GENERATED DOCUMENT - DO NOT SCALE THIS PRINT							RFP	CAD FILE ee7308	SIZE A	DRAWING NO. EE7308	PAGE OF 5	REV. 5
							DIST WP					



Regal Beloit America, Inc.