

PRODUCT INFORMATION PACKET

Model No: 324TTFS6527

Catalog No: E677

40 HP, Severe Duty Motors, 3 phase, 1800 RPM, 575 V, 324T Frame, TEFC
Severe Duty Motors



Regal and Marathon are trademarks of Regal Rexnord Corporation or one of its affiliated companies.
©2021 Regal Rexnord Corporation, All Rights Reserved. MC017097E



Nameplate Specifications

Output HP	40 Hp	Output KW	30.0 kW
Frequency	60 Hz	Voltage	575 V
Current	38.0 A	Speed	1780 rpm
Service Factor	1.15	Phase	3
Efficiency	94.1 %	Power Factor	83
Duty	Continuous	Insulation Class	F
Design Code	B	KVA Code	G
Frame	324T	Enclosure	Totally Enclosed Fan Cooled
Thermal Protection	No	Ambient Temperature	40 °C
Drive End Bearing Size	6312	Opp Drive End Bearing Size	6311
UL	Recognized	CSA	Y
CE	Y	IP Code	54
Number of Speeds	1		

Technical Specifications

Electrical Type	Squirrel Cage Inverter Rated	Starting Method	Line Or Inverter
Poles	4	Rotation	Reversible
Resistance Main	.135 Ohms	Mounting	Rigid Base
Motor Orientation	Horizontal	Drive End Bearing	Ball
Opp Drive End Bearing	Ball	Frame Material	Cast Iron
Shaft Type	T	Overall Length	30.38 in
Frame Length	13.00 in	Shaft Diameter	2.125 in
Shaft Extension	5.49 in	Assembly/Box Mounting	F1/F2 Capable
Inverter Load	CONSTANT 20:1		
Connection Drawing	A-EE7300	Outline Drawing	A-SS28703-1300

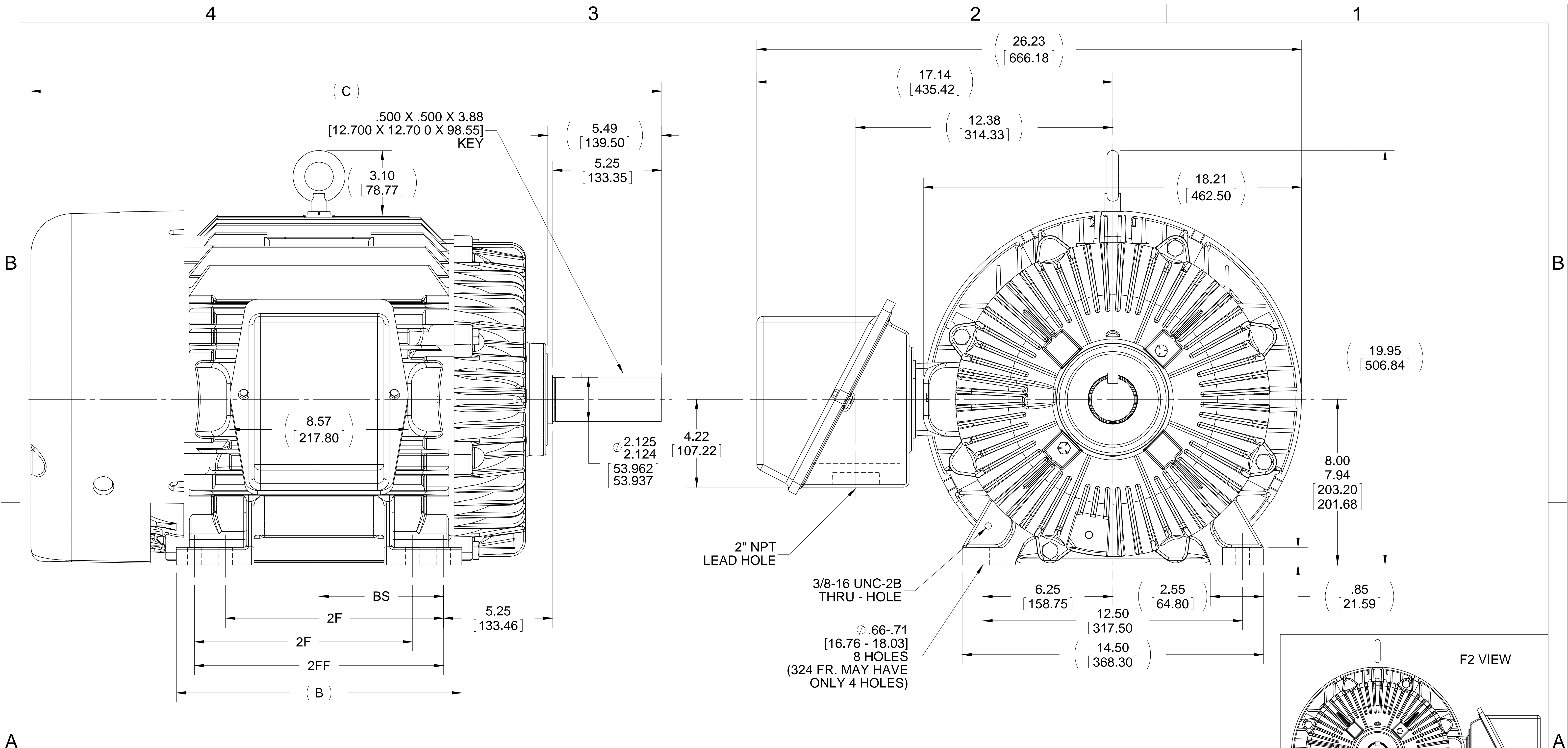

- NOTES:
 1. CONDUIT BOX CAN BE ROTATED IN 90° STEPS.
 2. CONDUIT BOX CAN BE MOUNTED ON OPPOSITE SIDE BY REMOVING BRACKETS AND TURNING FRAME 180°
 3. NAMEPLATES TO BE READ FROM CONDUIT BOX SIDE OF MOTOR.

DASH	FRAME	B	C	2F	2FF	BS
1150	324T	13.00 [330.20]	28.88 [733.55]	-	10.50 [266.70]	5.25 [133.35]
1300	324/6T	13.75 [349.25]	30.38 [771.65]	10.50 [266.70]	12.00 [304.80]	6.00 [152.40]
1450	326T	15.00 [381.00]	31.88 [809.75]	12.00 [304.80]	13.50 [342.90]	6.75 [171.45]

DRAWING REVISION V	REVISION BY W. JOERGER	DATE 03-28-2015
ECO ECO-0074425	APPROVED BY E. HEIL	DATE 03-28-2015
ECO DESCRIPTION CORRECTED FRAME/FOOT HOLE NUMBER NOTE		
<small>COPYRIGHT REGAL BELOIT AMERICA, INC. ALL RIGHTS RESERVED. PROPRIETARY AND CONFIDENTIAL INFORMATION - THIS DOCUMENT IS THE PROPERTY OF REGAL BELOIT AMERICA, INC. ("OWNER") AND CONTAINS OWNER'S PROPRIETARY INFORMATION. ANY PERSON, CORPORATION OR OTHER FIRM RECEIVING IT IS DEEMED, BY RECEIVING IT, TO AGREE THAT IT, AND/OR ANY PART OF IT, SHALL NOT BE DISCLOSED TO ANY PERSON, CORPORATION OR OTHER ENTITY, DUPLICATED, AND/OR USED, EXCEPT AS EXPRESSLY APPROVED IN WRITING IN ADVANCE BY OWNER. THIS DOCUMENT SHALL BE RETURNED TO OWNER UPON REQUEST. IT MAY BE SUBJECT TO CERTAIN RESTRICTIONS UNDER APPLICABLE EXPORT CONTROL LAWS AND REGULATIONS.</small>		

TOLERANCES UNLESS OTHERWISE SPECIFIED:
 DEC. INCH mm ANGLE
 .X ±0.1 [±2.5] ±7° 30"
 .XX ±0.03 [±0.76]
 XXX ±0.005 [±0.127]
 .XXXX ±0.0005 [±0.0127]
 REMOVE BURRS & BREAK SHARP
 EDGES: .003/.015 [0.076/.381]
 CORNER FILLETS: .02 [0.51]
 MACHINED SURFACES: 200 INCH mm 5.1
 mm SHOWN IN [BRACKETS]

DRAWN BY RM
DATE 01-12-1993
APPROVED BY GK
DATE 01-12-1993
REFERENCE
THIRD ANGLE PROJECTION

REGAL™ Regal Beloit America, Inc.

DESCRIPTION
OUTLINE
320T FR. - BB - TS - TEFC

MATERIAL PROCESS/FINISH

SIZE **B** DRAWING NUMBER **SS28703** SHEET 1 OF 1

**THREE PHASE - SINGLE VOLTAGE
MOTOR - CONDUIT BOX @ 'A'**

**TO REVERSE ROTATION:
INTERCHANGE ANY TWO
LINE LEAD CONNECTIONS.**

TERMINAL BLOCK WHEN SPECIFIED



VIEW OF TERMINAL END

**IF MOTOR HAS
6 LEADS**



A-9806 DECAL

**OPTIONAL CORD
CONNECTION**



DRAWING REVISION AB	REVISION BY JJB	DATE 06-27-2017
ECO ECO-0125361	APPROVED BY TB	DATE 06-27-2017
ECO DESCRIPTION UPDATED TO CURRENT STANDARDS		
<small>COPYRIGHT REGAL BELOIT AMERICA, INC. ALL RIGHTS RESERVED. PROPRIETARY AND CONFIDENTIAL INFORMATION - THIS DOCUMENT IS THE PROPERTY OF REGAL BELOIT AMERICA, INC. ("OWNER") AND CONTAINS OWNER'S PROPRIETARY INFORMATION. ANY PERSON, CORPORATION OR OTHER FIRM RECEIVING IT IS DEEMED, BY RECEIVING IT, TO AGREE THAT IT, AND/OR ANY PART OF IT, SHALL NOT BE DISCLOSED TO ANY PERSON, CORPORATION OR OTHER ENTITY, DUPLICATED, AND/OR USED, EXCEPT AS EXPRESSLY APPROVED IN WRITING IN ADVANCE BY OWNER. THIS DOCUMENT SHALL BE RETURNED TO OWNER UPON REQUEST. IT MAY BE SUBJECT TO CERTAIN RESTRICTIONS UNDER APPLICABLE EXPORT CONTROL LAWS AND REGULATIONS.</small>		



DRAWN BY DA
DATE 03-26-1993
APPROVED BY TB
DATE 03-26-1993
REFERENCE
THIRD ANGLE PROJECTION

Regal Beloit America, Inc.	
DESCRIPTION CONNECTION DIAGRAM EXTERNAL - SINGLE VOLTAGE - 3Ø MOTOR	
MATERIAL	PROCESS/FINISH
SIZE A	DRAWING NUMBER EE7300
SHEET 1 OF 1	

CERTIFICATION DATA SHEET

Model#: 324TTFS6527 ET
CONN. DIAGRAM: A-EE7300
OUTLINE: A-SS28703-1300

WINDING#: K3244127 NONE 3
ASSEMBLY: F1/F2 CAPABLE

TYPICAL MOTOR PERFORMANCE DATA

HP	KW	SYNC. RPM	F.L. RPM	FRAME	ENCLOSURE	KVA CODE	DESIGN
40	30	1800	1780	324T	TEFC	G	B

PH	Hz	VOLTS	FL AMPS	START TYPE	DUTY	INSL	S.F	AMB°C	ELEVATION
3	60	575	38	LINE OR INVERTER	CONTINUOUS	F3	1.15	40	3300

FULL LOAD EFF: 94.1	3/4 LOAD EFF: 94.5	1/2 LOAD EFF: 94.5	GTD. EFF	ELEC. TYPE	NO LOAD AMPS
FULL LOAD PF: 83	3/4 LOAD PF: 79.5	1/2 LOAD PF: 71	93.6	SQ CAGE INV RATED	14

F.L. TORQUE	LOCKED ROTOR AMPS	L.R. TORQUE	B.D. TORQUE	F.L. RISE°C
118 LB-FT	232	218 LB-FT 185	305 LB-FT 258	65

SOUND PRESSURE @ 3 FT.	SOUND POWER	ROTOR WK^2	MAX. WK^2	SAFE STALL TIME	STARTS /HOUR	APPROX. MOTOR WGT
65 dBA	75 dBA	8.8 LB-FT^2	275 LB-FT^2	25 SEC.	2	700 LBS.

***** SUPPLEMENTAL INFORMATION *****

DE BRACKET TYPE	ODE BRACKET TYPE	MOUNT TYPE	ORIENTATION	SEVERE DUTY	HAZARDOUS LOCATION	DRIP COVER	SCREENS	PAINT
STANDARD	STANDARD	RIGID	HORIZONTAL	PREMIUM SEVERE DUTY	DIVISION 2 T2B	FALSE	NONE	BLUE (EPOXY)

BEARINGS		GREASE	SHAFT TYPE	SPECIAL DE	SPECIAL ODE	SHAFT MATERIAL	FRAME MATERIAL
DE	OPE	POLYREX EM	T	NONE	NONE	1045 HOT ROLLED (C-204)	CAST IRON
BALL	BALL						
6312	6311						

THERMO-PROTECTORS				THERMISTORS	CONTROL	SPACE /n HEATERS
THERMOSTATS	PROTECTORS	WDG RTDs	BRG RTDs	NONE	FALSE	NONE VOLTS
NONE	NOT	NONE	NONE			

If Inverter equals NONE, contact factory for further information

*
N
O
T
E
S
*

INVERTER TORQUE: CONSTANT 20:1 INV. HP SPEED RANGE: 1.5 X BASE SPEED
ENCODER: NONE NONE NONE NONE NONE PPR
BRAKE: NONE NONE NONE P/N NONE NONE NONE NONE FT-LB NONE V NONE Hz

DATE: 06/21/2017 05:18:13 AM
 FORM 3531 REV.3 02/07/99
 ** Subject to change without notice.

Data Sheet

Date: 6/19/2017

324TFS6527

Customer: _____



Attention: _____

Submittal

Submitted by: FAREEDA DUDEKULA

Data @ 575 V

Motor Load Data

Load	0%	25%	50%	75%	100%	115%	125%	LR	
Current (Amps)	14.0	16.8	22.4	29.8	38.0	43.2	47.2	232	
Torque (ft-lb)	0.00	29.5	58.5	88.5	118	136	148	218	
RPM	1800	1795	1790	1785	1780	1,775	1772	0	
Efficiency (%)		91.0	94.5	94.5	94.1	94.1	94.1		
P.F. (%)	4.5	49.5	71.0	79.5	83.0	83.5	84.0	34.0	

Motor Speed Data

	LR	Pull-Up	BD	Rated	Idle
Speed (RPM)	0	900	1685	1780	1800
Current (Amps)	232	204	132	38.0	14.0
Torque (ft-lb)	218	190	305	118	0.00

Information Block

HP	40.0
Sync. RPM	1800
Frame	324
Enclosure	TEFC
Construction	TFN
Voltage	575 V
Frequency	60 Hz
Design	B
LR Code letter	G
Service Factor	1.15
Temp Rise @ FL	65 °C
Duty	CONT
Ambient	40 °C
Elevation	1,000 feet
Rotor/Shaft wk ²	8.8 Lb-Ft ²
Ref Wdg	K3244127 NONE
Sound Pressure @ 1M	65 dBA
VFD Rating	CONSTANT 20:1
Outline Dwg	A-SS28703-1300
Conn. Diag	A-EE7300

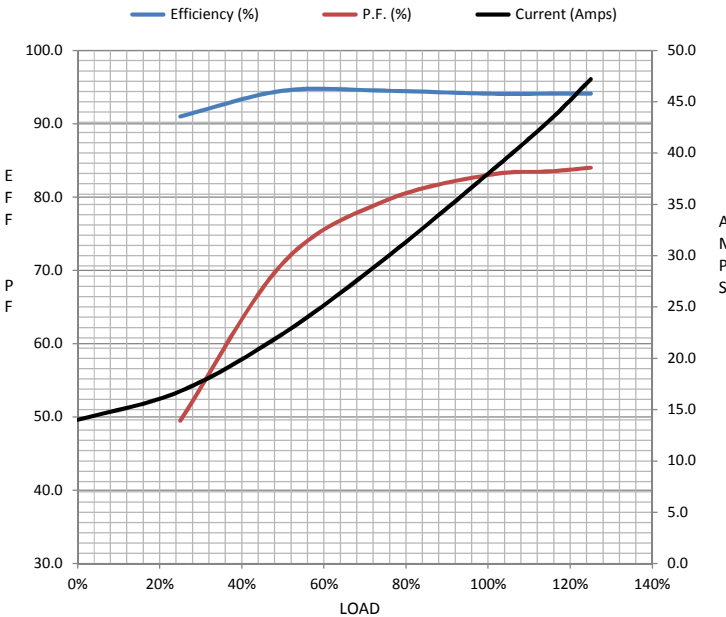

Additional Specifications:

0

0

EQUIV CKT (OHMS / PHASE)				
R1	R2	X1	X2	Xm
0.1290	0.1030	0.9050	1.2460	21.1150

Speed -Torque Curve

