

PRODUCT INFORMATION PACKET

marathon[®]
Motors

Model No: 324TTFCD6101
Catalog No: GT10117
20,900,TEFC,324T,3/60/230/460
Miscellaneous

Regal and Marathon are trademarks of Regal Rexnord Corporation or one of its affiliated companies.
©2021 Regal Rexnord Corporation, All Rights Reserved. MC017097E

RegalRexnord

Nameplate Specifications

Output HP	20 Hp	Output KW	14.9 kW
Frequency	60 Hz	Voltage	230/460 V
Current	54.0/27.0 A	Speed	885 rpm
Service Factor	1.15	Phase	3
Efficiency	90.2 %	Power Factor	77
Duty	Continuous	Insulation Class	F
Design Code	B	KVA Code	F
Frame	324T	Enclosure	Totally Enclosed Fan Cooled
Thermal Protection	No	Ambient Temperature	40 °C
Drive End Bearing Size	6312	Opp Drive End Bearing Size	6212
UL	Recognized	CSA	Y
CE	Y	IP Code	55
Number of Speeds	1		

Technical Specifications

Electrical Type	Squirrel Cage Inverter Rated	Starting Method	Line Or Inverter
Poles	8	Rotation	Selective Clockwise
Resistance Main	.3482 Ohms	Mounting	Rigid Base
Motor Orientation	Horizontal	Drive End Bearing	Ball
Opp Drive End Bearing	Ball	Frame Material	Cast Iron
Shaft Type	T	Assembly/Box Mounting	F1/F2 CAPABLE
Outline Drawing	SS312782-100	Connection Drawing	EE7308FT

This is an uncontrolled document once printed or downloaded and is subject to change without notice. Date Created:10/14/2021

4				3				2			1
DASH NO.	B	C	E	2E	2F	2FF	BA	BS	MOUNTING	FRAME	
100	12.71	29.69	6.25	12.50	---	10.50	5.25	5.25	F1 OR F2	324T	
200	14.21	31.19			10.50	12.00		6.00		324/326T	

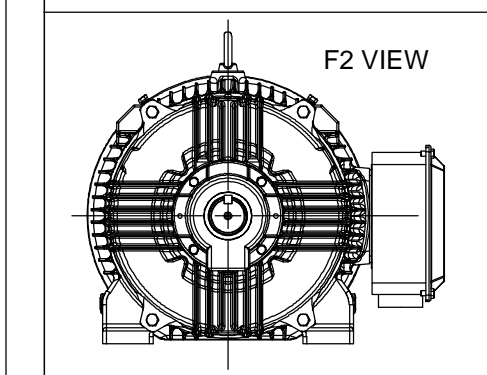
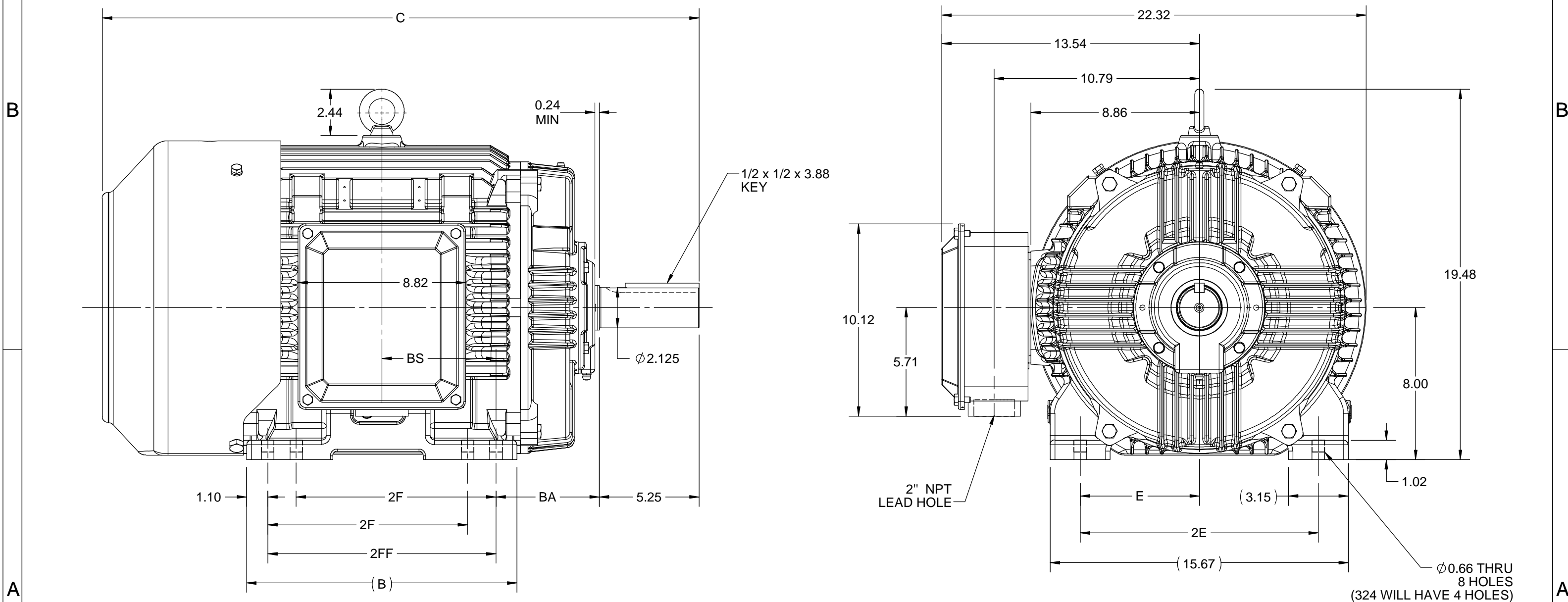

DRAWING REVISION C	REVISION BY ASHOK N	REV DATE/© DATE 14/10/2020
ECO ECO-0194008	APPROVED BY GNK	DATE 14/10/2020
ECO DESCRIPTION DRAWING UPDATED COPYRIGHT (PER REVISION DATE) REGAL BELOIT AMERICA, INC. ALL RIGHTS RESERVED. PROPRIETARY AND CONFIDENTIAL INFORMATION - THIS DOCUMENT IS THE PROPERTY OF REGAL BELOIT AMERICA, INC. ("OWNER") AND CONTAINS OWNER'S PROPRIETARY INFORMATION. ANY PERSON, CORPORATION OR OTHER FIRM RECEIVING IT IS DEEMED, BY RECEIVING IT, TO AGREE THAT IT, AND/OR ANY PART OF IT, SHALL NOT BE DISCLOSED TO ANY PERSON, CORPORATION OR OTHER ENTITY, DUPLICATED, AND/OR USED, EXCEPT AS EXPRESSLY APPROVED IN WRITING IN ADVANCE BY OWNER. THIS DOCUMENT SHALL BE RETURNED TO OWNER UPON REQUEST. IT MAY BE SUBJECT TO CERTAIN RESTRICTIONS UNDER APPLICABLE EXPORT CONTROL LAWS AND REGULATIONS.		

PRIMARY DIMENSIONS ARE INCH
mm DIMENSIONS IN [BRACKETS]
ARE FOR REFERENCE ONLY

DRAWN BY NIV	REGAL ® Regal Beloit America, Inc.
DATE 25/03/2016	
APPROVED BY SBD	DESCRIPTION OUTLINE 324/326T FR-NEMA-TEFC
DATE 25/03/2016	MATERIAL
REFERENCE	PROCESS/FINISH
THIRD ANGLE PROJECTION	SIZE B
	DRAWING NUMBER SS312782
	SHEET 1 OF 1

HIGH VOLTAGE

THREE PHASE
DUAL VOLTAGE MOTOR

EE7308FT

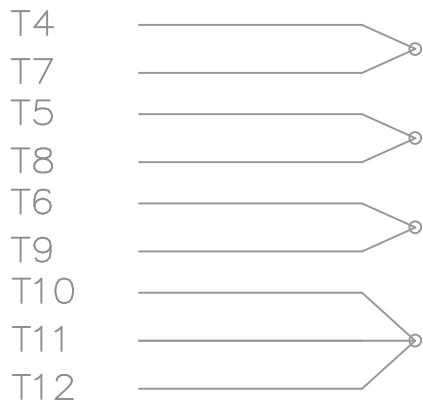
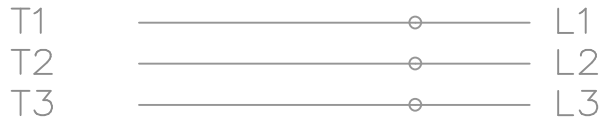

LOW VOLTAGE

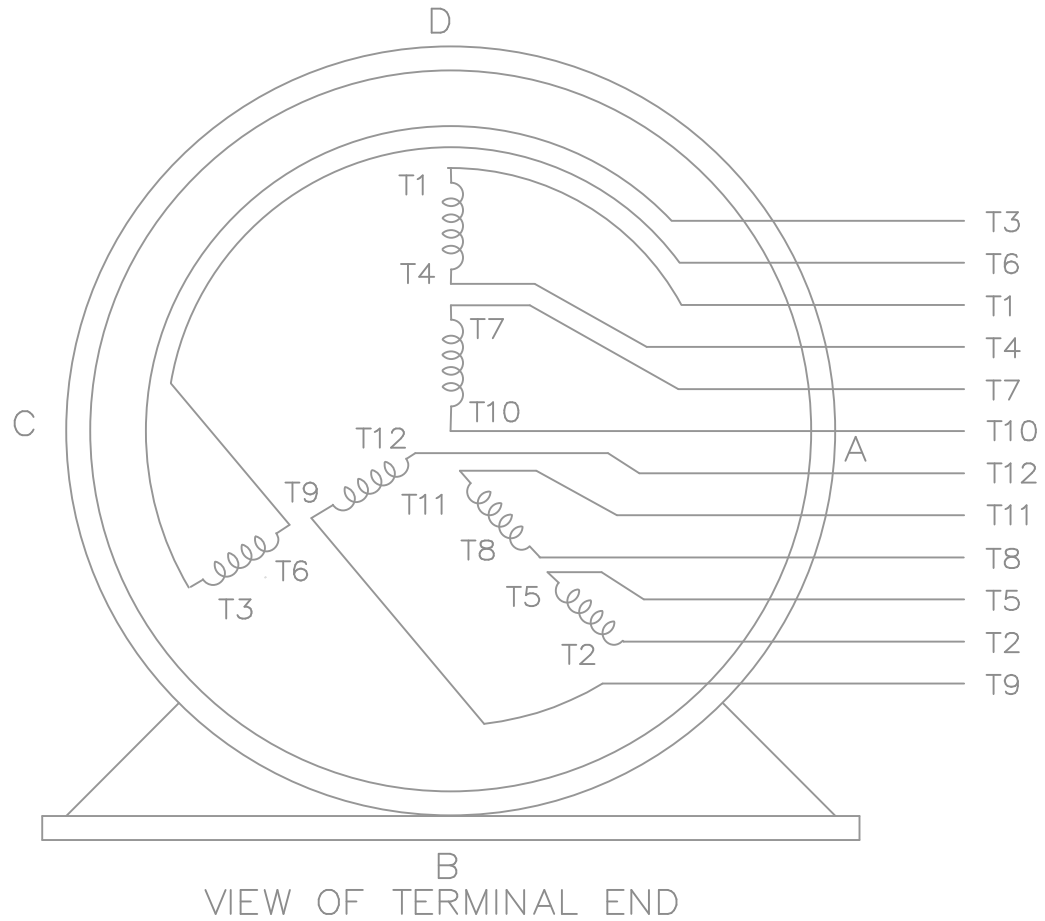
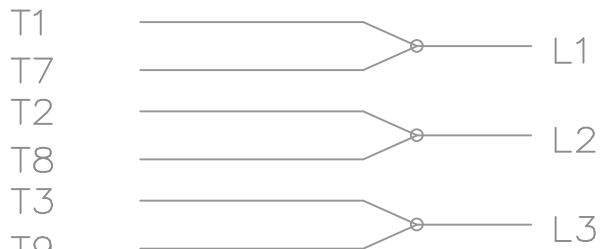

				TOLERANCES UNLESS SPECIFIED		 REGAL-BELOIT CORPORATION	DRAWN JJB 06-05-2007			
				DEC.	INCHES		CHK ML 06-05-2007			
				.X	± -		APPD BW 06-05-2007			
				.XX	± -	TITLE CONNECTION DIAGRAM 3Ø - DUAL VOLTAGE MOTOR	SCALE			
				.XXX	± -		REF			
1	NEW DRAWING	MU79979	JJB 06/05/2007	.XXXX	± -		MAT'L.	FMF		
NO.	REVISION		BY & DATE	CHK	ANG	± -	FINISH	PREV		
THIS DRAWING IN DESIGN AND DETAIL IS OUR PROPERTY AND MUST NOT BE USED EXCEPT IN CONNECTION WITH OUR WORK ALL RIGHTS OF DESIGN AND INVENTION ARE RESERVED THIS IS AN ELECTRONICALLY GENERATED DOCUMENT - DO NOT SCALE THIS PRINT				RFP	CAD FILE EE7308FT		SIZE A	DRAWING NO. EE7308FT	PAGE OF	REV. 1
				DIST	WA-LB-WP-LM					