

PRODUCT INFORMATION PACKET

Model No: 286TTTNA16541

Catalog No: U1874

XRI®-SD Severe Duty Motor, 30 & 25 HP, 3 Ph, 60 & 50 Hz, 230/460 & 190/380 V, 1800 & 1500 RPM,
286TV Frame, TEAO



Regal and Marathon are trademarks of Regal Rexnord Corporation or one of its affiliated companies.

©2023 Regal Rexnord Corporation, All Rights Reserved. MC017097E

Nameplate Specifications

Phase	3	Output HP	30 & 25 Hp
Output KW	22.4 & 18.7 kW	Voltage	230/460 & 190/380 V
Speed	1773 & 1475 rpm	Service Factor	1.15 & 1.15
Frame	286TV	Enclosure	Totally Enclosed Air Over
Thermal Protection	No Protection	Efficiency	94.1 & 93.6 %
Ambient Temperature	40 °C	Frequency	60 & 50 Hz
Current	73/36.5 & 74/37 A	Power Factor	82
Duty	Continuous	Insulation Class	F
Design Code	B	KVA Code	G
Drive End Bearing Size	6311	Opp Drive End Bearing Size	6210
UL	Recognized	CSA	Y
CE	Y	IP Code	56
Number of Speeds	1		

Technical Specifications

Electrical Type	Squirrel Cage Inverter Rated	Starting Method	Line Or Inverter
Poles	4	Rotation	Reversible
Resistance Main	.205 Ohms	Mounting	Rigid Base
Motor Orientation	Horizontal Or Up Or Down	Drive End Bearing	Ball
Opp Drive End Bearing	Ball	Frame Material	Cast Iron
Shaft Type	T	Overall Length	24.92 in
Frame Length	14.25 in	Shaft Diameter	1.875 in
Shaft Extension	4.83 in	Assembly/Box Mounting	F1/F2 CAPABLE
Outline Drawing	B-SS311239-1425	Connection Drawing	A-EE7308

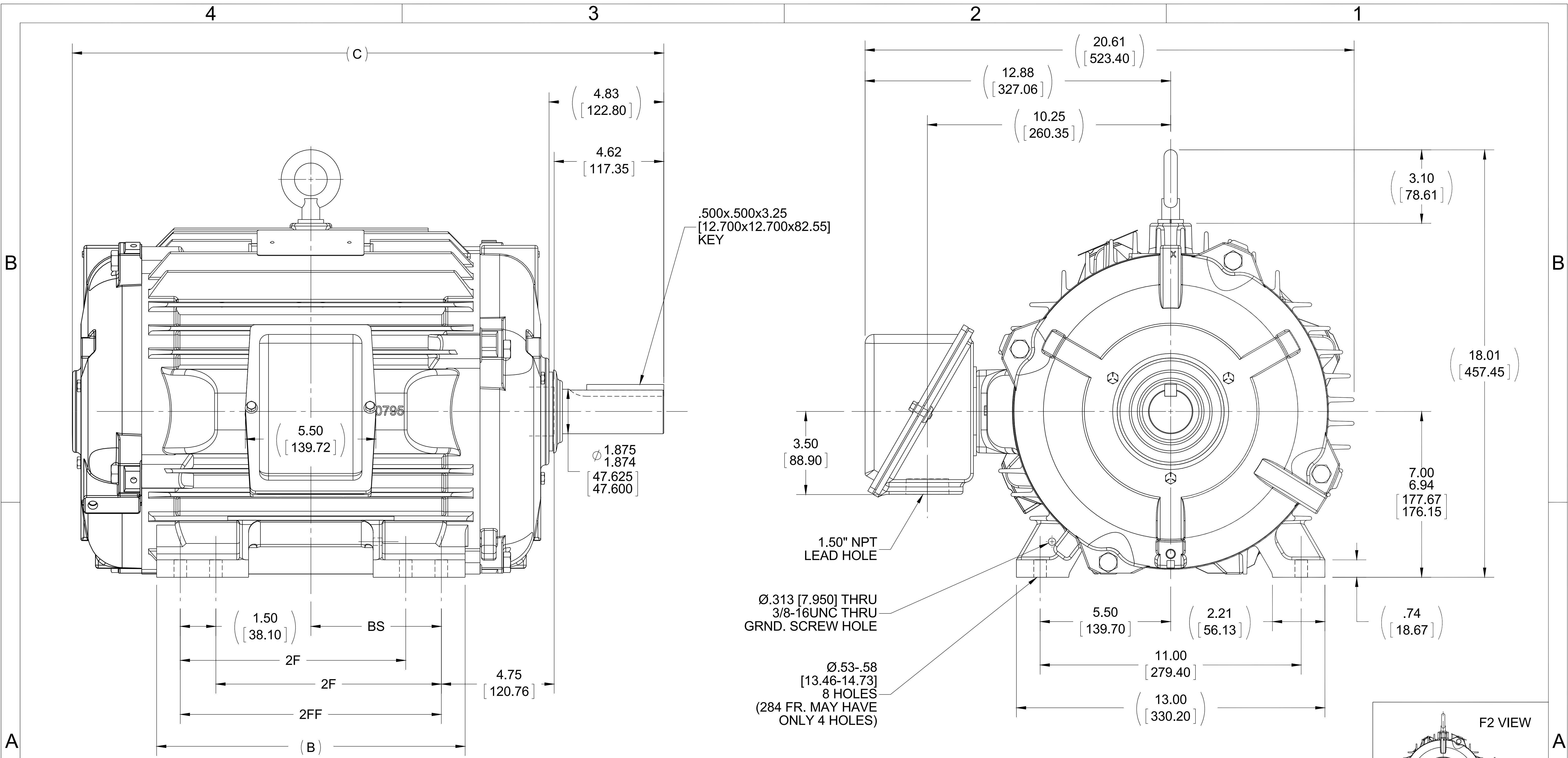

- NOTES:
 1. CONDUIT BOX CAN BE ROTATED IN 90° STEPS.
 2. CONDUIT BOX CAN BE MOUNTED ON OPPOSITE SIDE BY REMOVING BRACKETS AND TURNING FRAME 180°.
 3. NAMEPLATE TO BE READ FROM CONDUIT BOX SIDE OF MOTOR.

DASH	FRAME	B	C	BS	2F	2FF
1275	284T	12.50 [317.50]	23.42 [594.87]	4.75 [120.65]	---	9.50 [241.30]
1425	284/286T	13.00 [330.20]	24.92 [632.97]	5.50 [139.70]	9.50 [241.30]	11.00 [279.40]

DRAWING REVISION E	REVISION BY W. JOERGER	DATE 07-01-2015
ECO ECO-0080734	APPROVED BY E. HEIL	DATE 07-01-2015
ECO DESCRIPTION REMOVED COVER PLATE AND SEAL FROM O.D.E.		
<small>COPYRIGHT REGAL BELOIT AMERICA, INC. ALL RIGHTS RESERVED. PROPRIETARY AND CONFIDENTIAL INFORMATION - THIS DOCUMENT IS THE PROPERTY OF REGAL BELOIT AMERICA, INC. ("OWNER") AND CONTAINS OWNER'S PROPRIETARY INFORMATION. ANY PERSON, CORPORATION OR OTHER FIRM RECEIVING IT IS DEEMED, BY RECEIVING IT, TO AGREE THAT IT, AND/OR ANY PART OF IT, SHALL NOT BE DISCLOSED TO ANY PERSON, CORPORATION OR OTHER ENTITY, DUPLICATED, AND/OR USED, EXCEPT AS EXPRESSLY APPROVED IN WRITING IN ADVANCE BY OWNER. THIS DOCUMENT SHALL BE RETURNED TO OWNER UPON REQUEST. IT MAY BE SUBJECT TO CERTAIN RESTRICTIONS UNDER APPLICABLE EXPORT CONTROL LAWS AND REGULATIONS.</small>		

TOLERANCES UNLESS OTHERWISE SPECIFIED:
 DEC. INCH mm ANGLE
 .X ±0.1 [±2.5] ±7° 30"
 .XX ±0.03 [±0.76]
 .XXX ±0.005 [±0.127]
 .XXXX ±0.0005 [±0.0127]
 REMOVE BURRS & BREAK SHARP EDGES: .003/.015 [0.076/.381]
 CORNER FILLETS: .02 [0.51]
 MACHINED SURFACES: 200 INCH mm 5.1
 mm SHOWN IN [BRACKETS]

DRAWN BY NJS
DATE 10-03-2001
APPROVED BY BW
DATE 10-05-2001
REFERENCE
THIRD ANGLE PROJECTION

REGAL ™ Regal Beloit America, Inc.	
DESCRIPTION OUTLINE	
280T FR. - TEAO / TENV - BB - STD - 12.50" LAM	
MATERIAL	PROCESS/FINISH
SIZE B	DRAWING NUMBER SS311239
	SHEET 1 OF 1

EE7308

THREE PHASE
DUAL VOLTAGE MOTOR



VIEW OF TERMINAL END

REF.
WINDING DIAGRAM

T8Y, T2Y, T2BL, T4BX, T2EC, T2G
T6BZ, T2B, T6BL, T4AV, T6B, T4B

OPTIONAL CORD
CONNECTION

L1 — WHITE
L2 — RED
L3 — BLACK

NO.	REVISION	BY & DATE	CHK	ANG	TOLERANCES UNLESS SPECIFIED		FINISH	DRAWN RM 11/20/1990				
					DEC.	INCHES						
5	CHG TO REGAL LOGO	SL 09/10/2015	AB					CHK ML 11/21/1990				
4	REVISED IEC NOTATIONS	MSG 11/15/2011	CMN	.X	±.1			APPD SAS 04/24/2003				
3	ADDED IEC NOTATIONS... (U1), (V1) ETC. MU95194	MSG 5/10/2010	MJS	.XX	±.02			SCALE 1=1				
2	ADDED THE OPTIONAL CORD CONNECTION MU46318	RDH 04/24/2003	DRS	.XXX	±.005		TITLE CONNECTION DIAGRAM 3Ø - DUAL VOLTAGE MOTOR	REF				
1	REDRAWN	RM 11/20/1990		.XXXX	±.0005		MAT'L.	FMF				
					±7'30"			PREV				
THIS DRAWING IN DESIGN AND DETAIL IS OUR PROPERTY AND MUST NOT BE USED EXCEPT IN CONNECTION WITH OUR WORK ALL RIGHTS OF DESIGN AND INVENTION ARE RESERVED THIS IS AN ELECTRONICALLY GENERATED DOCUMENT - DO NOT SCALE THIS PRINT							RFP	CAD FILE ee7308	SIZE A	DRAWING NO. EE7308	PAGE OF 5	REV. 5
							DIST WP					



Regal Beloit America, Inc.

CERTIFICATION DATA SHEET

Model#: 286TTTNA16541 AA
CONN. DIAGRAM: A-EE7308
OUTLINE: B-SS311239-1425

WINDING#: K2864159 R11 6
ASSEMBLY: F1/F2 CAPABLE

TYPICAL MOTOR PERFORMANCE DATA

HP	KW	SYNC. RPM	F.L. RPM	FRAME	ENCLOSURE	KVA CODE	DESIGN
30&25	22.4&18.7	1800	1773&1475	286TV	TEAO	G	B

PH	Hz	VOLTS	FL AMPS	START TYPE	DUTY	INSL	S.F	AMB°C	ELEVATION
3	60/50	230/460#190/ 380	73/36.5&74/37	LINE OR INVERTER	CONTINUOU S	F3	1.15/1.15	40	3300

FULL LOAD EFF: 94.1&93.6	3/4 LOAD EFF: 94.1	1/2 LOAD EFF: 93.6	GTD. EFF	ELEC. TYPE	NO LOAD AMPS
FULL LOAD PF: 82&81.5	3/4 LOAD PF: 77	1/2 LOAD PF: 67.5	93.6	SQ CAGE INV RATED	30 / 15

F.L. TORQUE	LOCKED ROTOR AMPS	L.R. TORQUE	B.D. TORQUE	F.L. RISE°C
89 LB-FT	434 / 217	165 LB-FT 185	245 LB-FT 275	0

SOUND PRESSURE @ 3 FT.	SOUND POWER	ROTOR WK^2	MAX. WK^2	SAFE STALL TIME	STARTS /HOUR	APPROX. MOTOR WGT
- dBA	- dBA	4.6 LB-FT^2	225 LB-FT^2	25 SEC.	2	525 LBS.

***** SUPPLEMENTAL INFORMATION *****

DE BRACKET TYPE	ODE BRACKET TYPE	MOUNT TYPE	ORIENTATION	SEVERE DUTY	HAZARDOUS LOCATION	DRIP COVER	SCREENS	PAINT
STANDARD	STANDARD	RIGID	HORIZONTAL OR UP OR DOWN	PREMIUM SEVERE DUTY	NONE	FALSE	NONE	BLUE (EPOXY)

BEARINGS		GREASE	SHAFT TYPE	SPECIAL DE	SPECIAL ODE	SHAFT MATERIAL	FRAME MATERIAL
DE	OPE						
BALL	BALL	POLYREX EM	T	NONE	NONE	1045 HOT ROLLED (C-204)	CAST IRON
6311	6210						

THERMO-PROTECTORS				THERMISTORS	CONTROL	SPACE /n HEATERS
THERMOSTATS	PROTECTORS	WDG RTDs	BRG RTDs			
NONE	NOT	NONE	NONE	NONE	FALSE	NONE VOLTS

If Inverter equals NONE, contact factory for further information

*
N
O
T
E
S
*

INVERTER TORQUE: CONSTANT 20:1 INV. HP SPEED RANGE: NONE
ENCODER: NONE NONE NONE NONE NONE PPR
BRAKE: NONE NONE NONE P/N NONE NONE NONE NONE FT-LB NONE V NONE Hz

DATE: 06/21/2017 10:47:39 AM
 FORM 3531 REV.3 02/07/99

** Subject to change without notice.

Data Sheet

Date: 20-06-2017
 Customer: _____
 Attention: _____
 Submitted by: FAREEDA DUDEKULA



286TTNA16541

Submittal

Data @ 460 V

Motor Load Data

Load	0%	25%	50%	75%	100%	115%	125%	LR
Current (Amps)	15.0	17.5	22.5	29.0	36.5	40.0	45.5	217
Torque (ft-lb)	0.00	22.0	44.0	66.5	89.0	100	112	165
RPM	1800	1795	1785	1780	1773	1,770	1765	0
Efficiency (%)		89.5	93.6	94.1	94.1	94.1	93.6	
P.F. (%)	6.0	45.0	67.5	77.0	82.0	82.5	83.0	34.0

Motor Speed Data

	LR	Pull-Up	BD	Rated	Idle
Speed (RPM)	0	900	1650	1773	1800
Current (Amps)	217	200	130	36.5	15.0
Torque (ft-lb)	165	155	245	89.0	0.00

Information Block				
HP	30.0			
Sync. RPM	1800			
Frame	286			
Enclosure	TEAO			
Construction	TTN			
Voltage	230/460#190/38(V)			
Frequency	60 Hz			
Design	B			
LR Code letter	G			
Service Factor	1.15			
Temp Rise @ FL	0 °C			
Duty	CONT			
Ambient	40 °C			
Elevation	1,000 feet			
Rotor/Shaft wk ²	4.6 Lb-Ft ²			
Ref Wdg	K2864159 R11			
Sound Pressure @ 1M	999 dBA			
VFD Rating	CONSTANT 20:1			
Outline Dwg	B-SS311239-1425			
Conn. Diag	A-EE7308			
Additional Specifications:				
0				
365THFS8036				
EQUIV CKT (OHMS / PHASE)				
R1	R2	X1	X2	Xm
0.1250	0.1360	0.7240	0.9370	17.7850

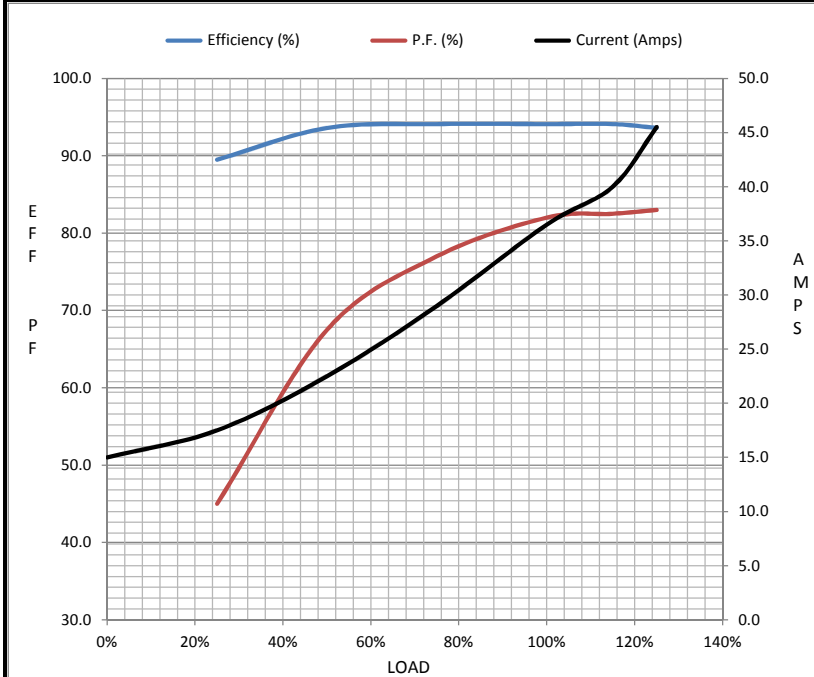

Speed - Torque Curve

