

PRODUCT INFORMATION PACKET

Model No: 286TTFNA16509

Catalog No: U2172A

General Purpose Pump Motor, 30 & 25 HP, 3 Ph, 60 & 50 Hz, 230/460 & 190/380 V, 3600 & 3000 RPM,
286 Frame, TEFC



Regal and Marathon are trademarks of Regal Rexnord Corporation or one of its affiliated companies.

©2023 Regal Rexnord Corporation, All Rights Reserved. MC017097E

Nameplate Specifications

Phase	3	Output HP	30 & 25 Hp
Output KW	22.4 & 18.7 kW	Voltage	230/460 & 190/380 V
Speed	3555 & 2952 rpm	Service Factor	1.15 & 1.15
Frame	286	Enclosure	Totally Enclosed Fan Cooled
Thermal Protection	No Protection	Efficiency	93 & 92.4 %
Ambient Temperature	40 °C	Frequency	60 & 50 Hz
Current	67/33.5 & 68/34 A	Power Factor	89.5
Duty	Continuous	Insulation Class	F
Design Code	B	KVA Code	G
Drive End Bearing Size	6312	Opp Drive End Bearing Size	6210
UL	Recognized	CSA	Y
CE	Y	IP Code	55
Number of Speeds	1		

Technical Specifications

Electrical Type	Squirrel Cage Inverter Rated	Starting Method	Line Or Inverter
Poles	2	Rotation	Reversible
Resistance Main	.3 Ohms	Mounting	Rigid Base
Motor Orientation	Horizontal	Drive End Bearing	Ball
Opp Drive End Bearing	Ball	Frame Material	Cast Iron
Shaft Type	Hyd Pump Adaptor Shaft	Overall Length	25.00 in
Shaft Diameter	1.875 in	Shaft Extension	4.62 in
Assembly/Box Mounting	F1/F2 Capable		
Connection Drawing	A-EE7308K	Outline Drawing	B-SS312742-1425

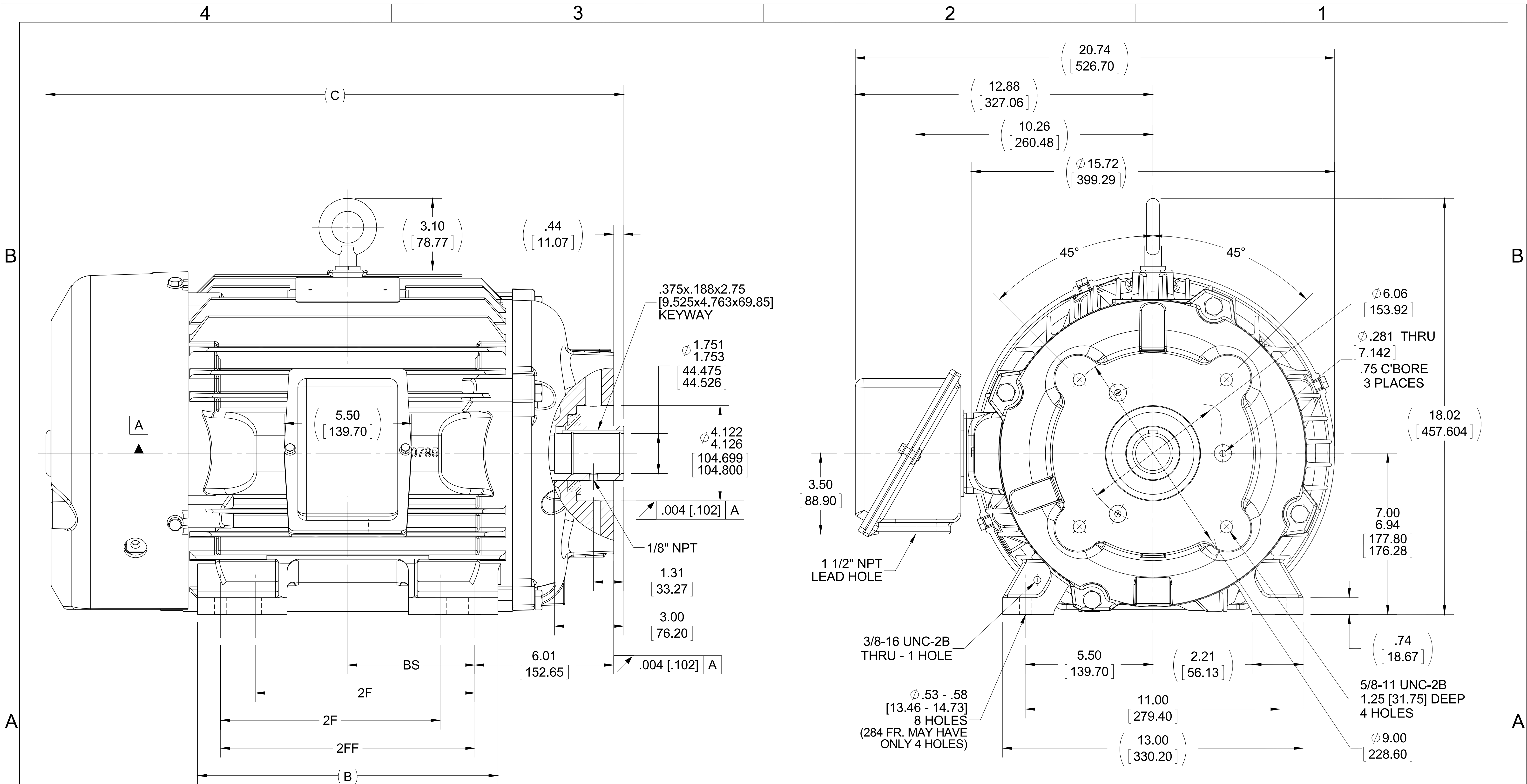

- NOTES:
1. CONDUIT BOX CAN BE ROTATED IN 90° STEPS.
 2. CONDUIT BOX CAN BE MOUNTED ON OPPOSITE SIDE BY REMOVING BRACKETS AND TURNING FRAME 180°.
 3. NAMEPLATE READ FROM CONDUIT BOX SIDE OF MOTOR.

1275	284TYZ	23.50 [596.93]	12.50 [317.50]	---	9.50 [241.30]	4.75 [120.59]
1425	284/286TYZ	25.00 [635.03]	13.00 [330.20]	9.50 [241.30]	11.00 [279.40]	5.50 [139.64]
DASH	FRAME	C	B	2F	2FF	BS
		4				

DRAWING REVISION A	REVISION BY	DATE
ECO ECO-0085820	APPROVED BY	DATE
ECO DESCRIPTION NEW DRAWING		
<small>COPYRIGHT REGAL BELOIT AMERICA, INC. ALL RIGHTS RESERVED. PROPRIETARY AND CONFIDENTIAL INFORMATION - THIS DOCUMENT IS THE PROPERTY OF REGAL BELOIT AMERICA, INC. ("OWNER") AND CONTAINS OWNER'S PROPRIETARY INFORMATION. ANY PERSON, CORPORATION OR OTHER FIRM RECEIVING IT IS DEEMED, BY RECEIVING IT, TO AGREE THAT IT, AND/OR ANY PART OF IT, SHALL NOT BE DISCLOSED TO ANY PERSON, CORPORATION OR OTHER ENTITY, DUPLICATED, AND/OR USED, EXCEPT AS EXPRESSLY APPROVED IN WRITING IN ADVANCE BY OWNER. THIS DOCUMENT SHALL BE RETURNED TO OWNER UPON REQUEST. IT MAY BE SUBJECT TO CERTAIN RESTRICTIONS UNDER APPLICABLE EXPORT CONTROL LAWS AND REGULATIONS.</small>		

TOLERANCES UNLESS OTHERWISE SPECIFIED:

DEC.	INCH	mm	ANGLE
.X	±0.1	[±2.5]	±7° 30"
.XX	±0.03	[±0.76]	
.XXX	±0.005	[±0.127]	
.XXXX	±0.0005	[±0.0127]	

REMOVE BURRS & BREAK SHARP EDGES: .003/.015 [0.076/.381] X 45°
CORNER FILLETS: R.02 [0.51]
MACHINED SURFACES: 200 INCH/mm 5.1

mm SHOWN IN [BRACKETS]

DRAWN BY MSG
DATE 10-06-2015
APPROVED BY TB
DATE 10-06-2015
REFERENCE
THIRD ANGLE PROJECTION

REGAL ™ Regal Beloit America, Inc.	
DESCRIPTION OUTLINE	
280TYZ FR. - TEFC - HYD PUMP PAD MOUNT	
MATERIAL	PROCESS/FINISH
SIZE B	DRAWING NUMBER SS312742
	SHEET 1 OF 1

LOW VOLTAGE



HIGH VOLTAGE



VIEW OF TERMINAL END

			TOLERANCES UNLESS SPECIFIED		 REGAL - BELOIT CORPORATION	DRAWN PGK 06-04-1997					
NO.	REVISION	BY & DATE	CHK	ANG		±	INCHES	SCALE	PREV		
E	CORRECTED IEC MARKINGS ECD-0111208	WGJ 01-23-2017	EMH	DEC.				CHK ML 06-05-1997			
D	RE-DRAWN WITH REGAL LOGO ECD-0110493	WGJ 09-30-2016	EMH	.X	±.1			APPD GK 06-15-1997			
8	ADDED IEC DESIGNATIONS MU95020	TJW 4/30/2010	MJS	.XX	±.02		TITLE CONNECTION DIAGRAM				
7	REVISED HIGH VOLTAGE L2 WAS L3 CN52600-354	MRB 09-21-1998		.XXX	±.005		TITLE DELTA CON. - 3Ø - 9 LEADS	REF			
6	REDRAWN ON CADD	PGK 06-05-1997		.XXXX	±.0005		MAT'L.	FMF			
					±7'30"		FINISH				
THIS DRAWING IN DESIGN AND DETAIL IS OUR PROPERTY AND MUST NOT BE USED EXCEPT IN CONNECTION WITH OUR WORK ALL RIGHTS OF DESIGN AND INVENTION ARE RESERVED THIS IS AN ELECTRONICALLY GENERATED DOCUMENT - DO NOT SCALE THIS PRINT					RFP	CAD FILE EE7308K		SIZE A	DRAWING NO. EE7308K	PAGE OF	REV. E
					DIST						

CERTIFICATION DATA SHEET

Model#: 286TTFNA16509 AA
CONN. DIAGRAM: A-EE7308K
OUTLINE: B-SS312742-1425

WINDING#: K2862155 NONE 1
ASSEMBLY: F1/F2 CAPABLE

TYPICAL MOTOR PERFORMANCE DATA

HP	KW	SYNC. RPM	F.L. RPM	FRAME	ENCLOSURE	KVA CODE	DESIGN
30&25	22.4&18.7	3600	3555&2952	286	TEFC	G	B

PH	Hz	VOLTS	FL AMPS	START TYPE	DUTY	INSL	S.F	AMB°C	ELEVATION
3	60/50	230/460#190/ 380	67/33.5&68/34	LINE OR INVERTER	CONTINUOU S	F3	1.15/1.15	40	3300

FULL LOAD EFF: 93&92.4	3/4 LOAD EFF: 93.6	1/2 LOAD EFF: 93	GTD. EFF	ELEC. TYPE	NO LOAD AMPS
FULL LOAD PF: 89.5&90	3/4 LOAD PF: 87	1/2 LOAD PF: 81	92.4	SQ CAGE INV RATED	19 / 9.5

F.L. TORQUE	LOCKED ROTOR AMPS	L.R. TORQUE	B.D. TORQUE	F.L. RISE°C
44.5 LB-FT	434 / 217	63 LB-FT 142	123 LB-FT 275	65

SOUND PRESSURE @ 3 FT.	SOUND POWER	ROTOR WK^2	MAX. WK^2	SAFE STALL TIME	STARTS /HOUR	APPROX. MOTOR WGT
72 dBA	82 dBA	2.7 LB-FT^2	35 LB-FT^2	20 SEC.	2	450 LBS.

***** SUPPLEMENTAL INFORMATION *****

DE BRACKET TYPE	ODE BRACKET TYPE	MOUNT TYPE	ORIENTATION	SEVERE DUTY	HAZARDOUS LOCATION	DRIP COVER	SCREENS	PAINT
HYD PUMP SAE MOUNT PAD	STANDARD	RIGID	HORIZONTAL	PREMIUM SEVERE DUTY	NONE	FALSE	NONE	BLUE (EPOXY)

BEARINGS		GREASE	SHAFT TYPE	SPECIAL DE	SPECIAL ODE	SHAFT MATERIAL	FRAME MATERIAL
DE	OPE						
BALL	BALL	POLYREX EM	HYD PUMP ADAPTOR SHAFT	NONE	NONE	1045 HOT ROLLED (C-204)	CAST IRON
6312	6210						

THERMO-PROTECTORS				THERMISTORS	CONTROL	SPACE /n HEATERS
THERMOSTATS	PROTECTORS	WDG RTDs	BRG RTDs			
NONE	NOT	NONE	NONE	NONE	FALSE	NONE VOLTS

If Inverter equals NONE, contact factory for further information

*
N
O
T
E
S
*

INVERTER TORQUE: CONSTANT 10:1 INV. HP SPEED RANGE: NONE
ENCODER: NONE NONE NONE NONE NONE PPR
BRAKE: NONE NONE NONE P/N NONE NONE NONE NONE FT-LB NONE V NONE Hz

DATE: 06/27/2017 03:56:25 AM
 FORM 3531 REV.3 02/07/99

** Subject to change without notice.

Data Sheet

Date: 29-06-2017
 Customer: _____
 Attention: _____
 Submitted by: FAREEDA DUDEKULA



286TTFNA16509

Submittal

Data @ 460 V

Motor Load Data

Load	0%	25%	50%	75%	100%	115%	125%	LR
Current (Amps)	9.5	12.7	18.5	26.0	33.5	38.5	42.0	217
Torque (ft-lb)	0.00	11.0	22.0	33.0	44.5	51.0	56.0	63.0
RPM	3600	3590	3578	3565	3555	3,547	3542	0
Efficiency (%)		89.5	93.0	93.6	93.0	93.0	92.4	
P.F. (%)	6.5	61.5	81.0	87.0	89.5	90.0	90.5	32.0

Motor Speed Data

	LR	Pull-Up	BD	Rated	Idle
Speed (RPM)	0	1800	3400	3555	3600
Current (Amps)	217	195	138	33.5	9.5
Torque (ft-lb)	63.0	56.0	123	44.5	0.00

Information Block				
HP	30.0			
Sync. RPM	3600			
Frame	286			
Enclosure	TEFC			
Construction	TFN			
Voltage	230/460#190/38(V)			
Frequency	60 Hz			
Design	A			
LR Code letter	G			
Service Factor	1.15			
Temp Rise @ FL	65 ° C			
Duty	CONT			
Ambient	40 ° C			
Elevation	1,000 feet			
Rotor/Shaft wk ²	2.70 Lb-Ft ²			
Ref Wdg	K2862155 NONE			
Sound Pressure @ 1M	72 dBA			
VFD Rating	CONSTANT 10:1			
Outline Dwg	B-SS312742-1425			
Conn. Diag	A-EE7308K			
Additional Specifications:				
0				
365THFS8036				
EQUIV CKT (OHMS / PHASE)				
R1	R2	X1	X2	Xm
0.1970	0.1040	0.7940	0.6050	#####

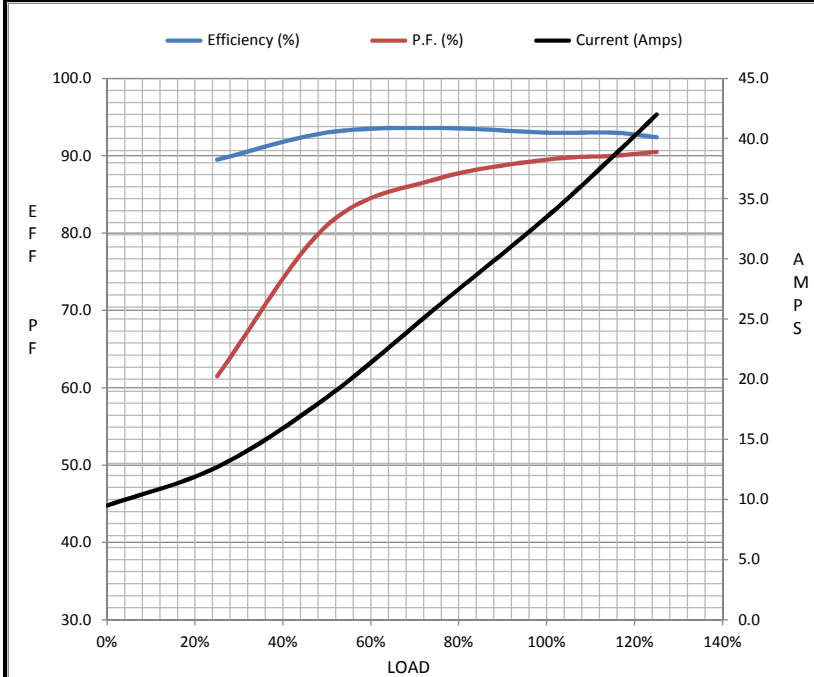

Speed - Torque Curve

