

PRODUCT INFORMATION PACKET

Model No: 284TTFNA16872

Catalog No: U2171A

General Purpose Pump Motor, 25 & 20 HP, 3 Ph, 60 & 50 Hz, 230/460 & 190/380 V, 1800 & 1500 RPM,
284 Frame, TEFC



Regal and Marathon are trademarks of Regal Rexnord Corporation or one of its affiliated companies.

©2023 Regal Rexnord Corporation, All Rights Reserved. MC017097E

Nameplate Specifications

Phase	3	Output HP	25 & 20 Hp
Output KW	18.7 & 14.9 kW	Voltage	230/460 & 190/380 V
Speed	1772 & 1472 rpm	Service Factor	1.15 & 1.15
Frame	284	Enclosure	Totally Enclosed Fan Cooled
Thermal Protection	No Protection	Efficiency	93.6 & 93 %
Ambient Temperature	40 °C	Frequency	60 & 50 Hz
Current	62/31 & 60/30 A	Power Factor	81
Duty	Continuous	Insulation Class	F
Design Code	B	KVA Code	G
Drive End Bearing Size	6312	Opp Drive End Bearing Size	6210
UL	Recognized	CSA	Y
CE	Y	IP Code	55
Number of Speeds	1		

Technical Specifications

Electrical Type	Squirrel Cage Inverter Rated	Starting Method	Line Or Inverter
Poles	4	Rotation	Reversible
Resistance Main	.271 Ohms	Mounting	Rigid Base
Motor Orientation	Horizontal	Drive End Bearing	Ball
Opp Drive End Bearing	Ball	Frame Material	Cast Iron
Shaft Type	Hyd Pump Adaptor Shaft	Overall Length	23.50 in
Shaft Diameter	1.875 in	Shaft Extension	4.62 in
Assembly/Box Mounting	F1/F2 Capable		
Connection Drawing	A-EE7308	Outline Drawing	B-SS312742-1275

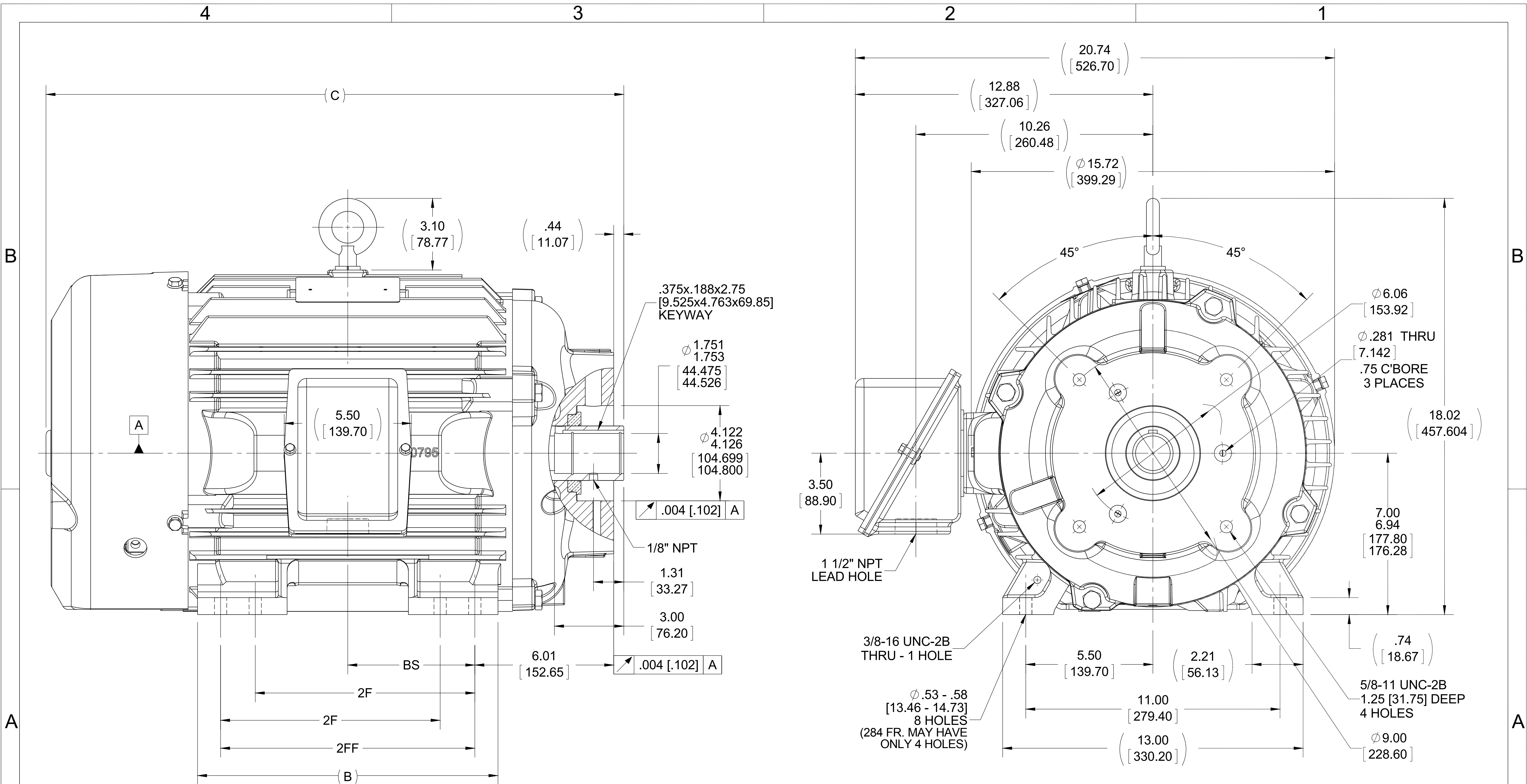

- NOTES:
1. CONDUIT BOX CAN BE ROTATED IN 90° STEPS.
 2. CONDUIT BOX CAN BE MOUNTED ON OPPOSITE SIDE BY REMOVING BRACKETS AND TURNING FRAME 180°.
 3. NAMEPLATE READ FROM CONDUIT BOX SIDE OF MOTOR.

1275	284TYZ	23.50 [596.93]	12.50 [317.50]	---	9.50 [241.30]	4.75 [120.59]
1425	284/286TYZ	25.00 [635.03]	13.00 [330.20]	9.50 [241.30]	11.00 [279.40]	5.50 [139.64]
DASH	FRAME	C	B	2F	2FF	BS
		4				

DRAWING REVISION A	REVISION BY	DATE
ECO ECO-0085820	APPROVED BY	DATE
ECO DESCRIPTION NEW DRAWING		
<small>COPYRIGHT REGAL BELOIT AMERICA, INC. ALL RIGHTS RESERVED. PROPRIETARY AND CONFIDENTIAL INFORMATION - THIS DOCUMENT IS THE PROPERTY OF REGAL BELOIT AMERICA, INC. ("OWNER") AND CONTAINS OWNER'S PROPRIETARY INFORMATION. ANY PERSON, CORPORATION OR OTHER FIRM RECEIVING IT IS DEEMED, BY RECEIVING IT, TO AGREE THAT IT, AND/OR ANY PART OF IT, SHALL NOT BE DISCLOSED TO ANY PERSON, CORPORATION OR OTHER ENTITY, DUPLICATED, AND/OR USED, EXCEPT AS EXPRESSLY APPROVED IN WRITING IN ADVANCE BY OWNER. THIS DOCUMENT SHALL BE RETURNED TO OWNER UPON REQUEST. IT MAY BE SUBJECT TO CERTAIN RESTRICTIONS UNDER APPLICABLE EXPORT CONTROL LAWS AND REGULATIONS.</small>		

TOLERANCES UNLESS OTHERWISE SPECIFIED:

DEC.	INCH	mm	ANGLE
.X	±0.1	[±2.5]	±7° 30"
.XX	±0.03	[±0.76]	
.XXX	±0.005	[±0.127]	
.XXXX	±0.0005	[±0.0127]	

REMOVE BURRS & BREAK SHARP EDGES: .003/.015 [0.076/.381] X 45° CORNER FILLETS: R.02 [51] MACHINED SURFACES: 200 INCH mm 5.1 mm SHOWN IN [BRACKETS]

DRAWN BY MSG
DATE 10-06-2015
APPROVED BY TB
DATE 10-06-2015
REFERENCE
THIRD ANGLE PROJECTION

REGAL ™ Regal Beloit America, Inc.	
DESCRIPTION OUTLINE	
280TYZ FR. - TEFC - HYD PUMP PAD MOUNT	
MATERIAL	PROCESS/FINISH
SIZE B	DRAWING NUMBER SS312742
	SHEET 1 OF 1



NO.	REVISION	BY & DATE	CHK	ANG	TOLERANCES UNLESS SPECIFIED		FINISH	DRAWN RM 11/20/1990				
					DEC.	INCHES						
5	CHG TO REGAL LOGO	SL 09/10/2015	AB					CHK ML 11/21/1990				
4	REVISED IEC NOTATIONS	MSG 11/15/2011	CMN	.X	±.1			APPD SAS 04/24/2003				
3	ADDED IEC NOTATIONS... (U1), (V1) ETC. MU95194	MSG 5/10/2010	MJS	.XX	±.02			SCALE 1=1				
2	ADDED THE OPTIONAL CORD CONNECTION MU46318	RDH 04/24/2003	DRS	.XXX	±.005		TITLE CONNECTION DIAGRAM 3Ø - DUAL VOLTAGE MOTOR	REF				
1	REDRAWN	RM 11/20/1990		.XXXX	±.0005		MAT'L.	FMF				
					±7'30"			PREV				
THIS DRAWING IN DESIGN AND DETAIL IS OUR PROPERTY AND MUST NOT BE USED EXCEPT IN CONNECTION WITH OUR WORK ALL RIGHTS OF DESIGN AND INVENTION ARE RESERVED THIS IS AN ELECTRONICALLY GENERATED DOCUMENT - DO NOT SCALE THIS PRINT							RFP	CAD FILE ee7308	SIZE A	DRAWING NO. EE7308	PAGE OF 5	REV. 5
							DIST WP					

CERTIFICATION DATA SHEET

Model#: 284TTFNA16872 AA
CONN. DIAGRAM: A-EE7308
OUTLINE: B-SS312742-1275

WINDING#: K2844161 NONE 9
ASSEMBLY: F1/F2 CAPABLE

TYPICAL MOTOR PERFORMANCE DATA

HP	KW	SYNC. RPM	F.L. RPM	FRAME	ENCLOSURE	KVA CODE	DESIGN
25&20	18.7&14.9	1800	1772&1472	284	TEFC	G	B

PH	Hz	VOLTS	FL AMPS	START TYPE	DUTY	INSL	S.F	AMB°C	ELEVATION
3	60/50	230/460#190/ 380	62/31&60/30	LINE OR INVERTER	CONTINUOU S	F3	1.15/1.15	40	3300

FULL LOAD EFF: 93.6&93	3/4 LOAD EFF: 94.1	1/2 LOAD EFF: 93.6	GTD. EFF	ELEC. TYPE	NO LOAD AMPS
FULL LOAD PF: 81&81	3/4 LOAD PF: 76	1/2 LOAD PF: 65.5	93	SQ CAGE INV RATED	26 / 13

F.L. TORQUE	LOCKED ROTOR AMPS	L.R. TORQUE	B.D. TORQUE	F.L. RISE°C
74 LB-FT	364 / 182	138 LB-FT 186	185 LB-FT 250	60

SOUND PRESSURE @ 3 FT.	SOUND POWER	ROTOR WK^2	MAX. WK^2	SAFE STALL TIME	STARTS /HOUR	APPROX. MOTOR WGT
65 dBA	75 dBA	4.2 LB-FT^2	175 LB-FT^2	50 SEC.	2	475 LBS.

***** SUPPLEMENTAL INFORMATION *****

DE BRACKET TYPE	ODE BRACKET TYPE	MOUNT TYPE	ORIENTATION	SEVERE DUTY	HAZARDOUS LOCATION	DRIP COVER	SCREENS	PAINT
HYD PUMP SAE MOUNT PAD	STANDARD	RIGID	HORIZONTAL	PREMIUM SEVERE DUTY	NONE	FALSE	NONE	BLUE (EPOXY)

BEARINGS		GREASE	SHAFT TYPE	SPECIAL DE	SPECIAL ODE	SHAFT MATERIAL	FRAME MATERIAL
DE	OPE						
BALL	BALL	POLYREX EM	HYD PUMP ADAPTOR SHAFT	NONE	NONE	1045 HOT ROLLED (C-204)	CAST IRON
6312	6210						

THERMO-PROTECTORS				THERMISTORS	CONTROL	SPACE /n HEATERS
THERMOSTATS	PROTECTORS	WDG RTDs	BRG RTDs			
NONE	NOT	NONE	NONE	NONE	FALSE	NONE VOLTS

If Inverter equals NONE, contact factory for further information

INVERTER TORQUE: CONSTANT 10:1
INV. HP SPEED RANGE: NONE
ENCODER: NONE
NONE NONE
NONE NONE PPR
BRAKE: NONE NONE
NONE P/N NONE
NONE NONE
NONE FT-LB NONE V NONE Hz

*
N
O
T
E
S
*

DATE: 06/27/2017 01:25:48 AM
 FORM 3531 REV.3 02/07/99
 ** Subject to change without notice.

Data Sheet

Date: 1/25/2019
 Customer: _____
 Attention: _____
 Submitted by: FAREEDA DUDEKULA



284TFNA16872

Submittal

Data @ 460 V

Motor Load Data

Load	0%	25%	50%	75%	100%	115%	125%	LR
Current (Amps)	13.0	15.0	19.1	24.6	31.0	35.0	40.0	182
Torque (ft-lb)	0.00	18.3	37.0	55.5	74.0	85.5	93.0	138
RPM	1800	1793	1787	1780	1772	1,767	1763	0
Efficiency (%)		90.2	93.6	94.1	93.6	93.0	93.0	
P.F. (%)	3.0	43.0	65.5	76.0	81.0	82.5	83.0	33.0

Motor Speed Data

	LR	Pull-Up	BD	Rated	Idle
Speed (RPM)	0	900	1662	1772	1800
Current (Amps)	182	169	108	31.0	13.0
Torque (ft-lb)	138	117	185	74.0	0.00

Information Block

HP	25.0			
Sync. RPM	1800			
Frame	284			
Enclosure	TEFC			
Construction	TFS			
Voltage	230/460#190/380 V			
Frequency	60 Hz			
Design	B			
LR Code letter	G			
Service Factor	1.15			
Temp Rise @ FL	60 °C			
Duty	CONT			
Ambient	40 °C			
Elevation	3,300 feet			
Rotor/Shaft wk ²	4.2 Lb-Ft ²			
Ref Wdg	K2844161 NONE			
Sound Pressure @ 1M	65 dBA			
VFD Rating	CONSTANT 10:1			
Outline Dwg	B-SS312742-1275			
Conn. Diag	A-EE7308			
Additional Specifications:				
0				
0				
EQUIV CKT (OHMS / PHASE)				
R1	R2	X1	X2	Xm
0.1810	0.1570	0.8480	1.0850	19.7750

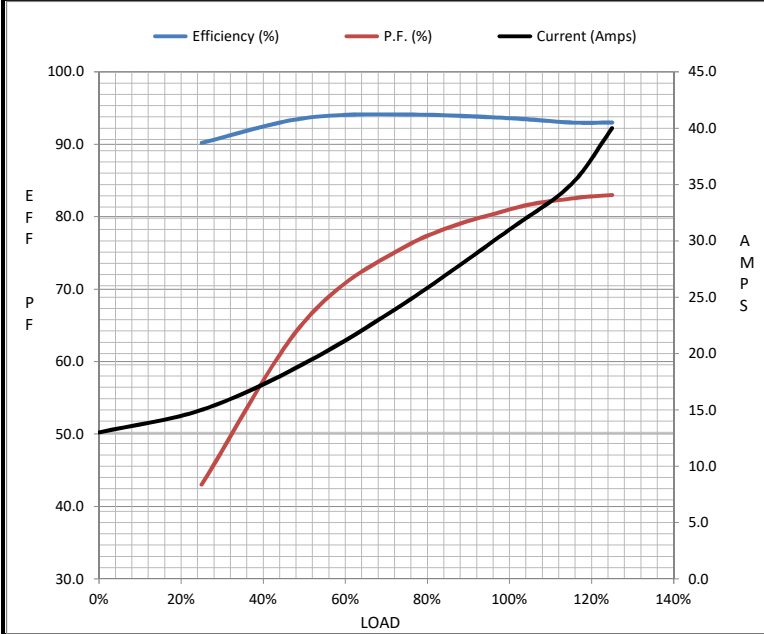

Speed - Torque Curve

