

PRODUCT INFORMATION PACKET

marathon®
Motors

Model No: 284TSTDBD4007

Catalog No: U1053

Fire Pump Motor, 30 HP, 3 Ph, 60 Hz, 190/380-400 V, 3600 RPM, 284TS Frame, DP

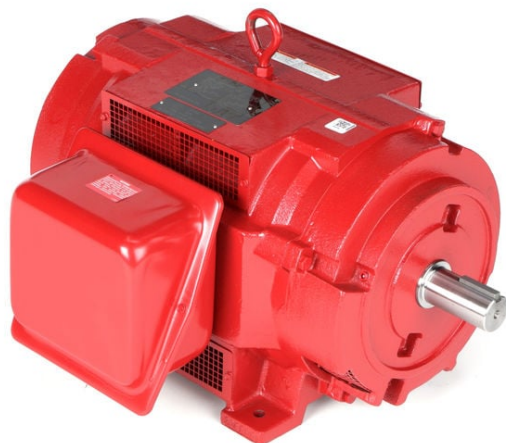

Regal and Marathon are trademarks of Regal Rexnord Corporation or one of its affiliated companies.
©2022 Regal Rexnord Corporation, All Rights Reserved. MC017097E

RegalRexnord

Nameplate Specifications

Output HP	30 Hp	Output KW	22.4 kW
Frequency	60 Hz	Voltage	190/380-400 V
Current	87.0/43.5-41.0 A	Speed	3560 rpm
Service Factor	1.15	Phase	3
Efficiency	91 %	Power Factor	86
Duty	Continuous	Insulation Class	F
Design Code	B	KVA Code	F
Frame	284TS	Enclosure	Drip Proof
Thermal Protection	No Protection	Ambient Temperature	50 °C
Drive End Bearing Size	6211	Opp Drive End Bearing Size	6211
UL	Listed	CSA	Y
CE	Y	IP Code	23
Number of Speeds	1		

Technical Specifications

Electrical Type	Squirrel Cage Induction Run	Starting Method	Part Wdg Start & Wye Start Delta Run
Poles	2	Rotation	Reversible
Resistance Main	.38 Ohms	Mounting	Rigid Base
Motor Orientation	Horizontal	Drive End Bearing	Ball
Opp Drive End Bearing	Ball	Frame Material	Rolled Steel
Shaft Type	TS	Overall Length	24.34 in
Frame Length	12.59 in	Shaft Diameter	1.625 in
Shaft Extension	3.25 in	Assembly/Box Mounting	F1/F2 CAPABLE
Outline Drawing	SS620709-284TS	Connection Drawing	EE7308AA

DASH NO.	B	C	D	E	2E	2F	2FF	BA	BS	MOUNTING	FRAME
100	15.55	24.23	7.00	5.50	11.00	9.50	11.00	4.75	10.80	F1 OR F2	284TS
200		25.61							12.18		286TS

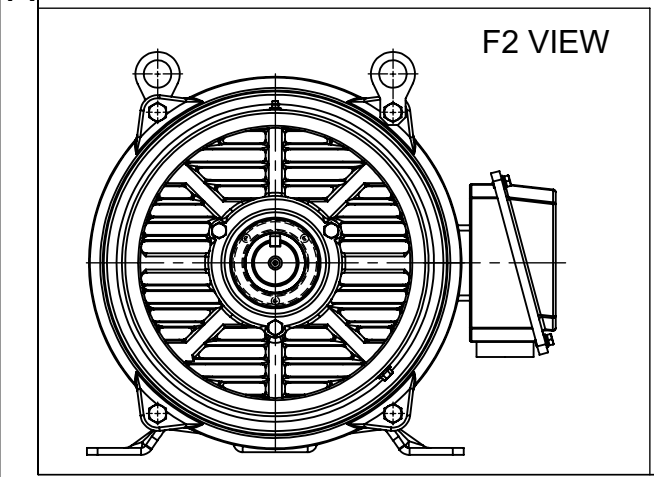
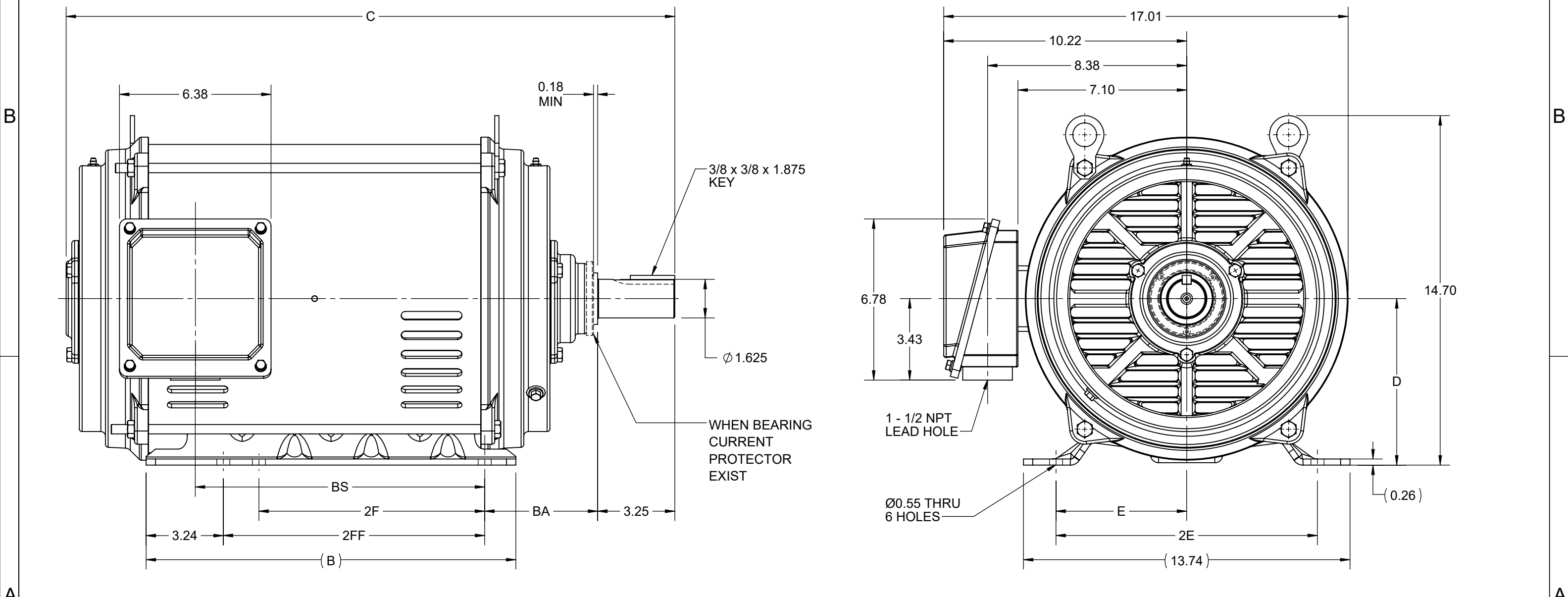

DRAWING REVISION D	REVISION BY GOPI J	REV DATE/© DATE 01/02/2022
REQUEST NUMBER CR-0006669	APPROVED BY SBD	DATE 01/02/2022
REQUEST NUMBER DESCRIPTION VIEWS UPDATED AS PER 3D		
<small>COPYRIGHT (PER REVISION DATE) REGAL BELOIT AMERICA, INC. ALL RIGHTS RESERVED. PROPRIETARY AND CONFIDENTIAL INFORMATION - THIS DOCUMENT IS THE PROPERTY OF REGAL BELOIT AMERICA, INC. ("OWNER") AND CONTAINS OWNER'S PROPRIETARY INFORMATION. ANY PERSON, CORPORATION OR OTHER FIRM RECEIVING IT IS DEEMED, BY RECEIVING IT, TO AGREE THAT IT, AND/OR ANY PART OF IT, SHALL NOT BE DISCLOSED TO ANY PERSON, CORPORATION OR OTHER ENTITY, DUPLICATED, AND/OR USED, EXCEPT AS EXPRESSLY APPROVED IN WRITING IN ADVANCE BY OWNER. THIS DOCUMENT SHALL BE RETURNED TO OWNER UPON REQUEST. IT MAY BE SUBJECT TO CERTAIN RESTRICTIONS UNDER APPLICABLE EXPORT CONTROL LAWS AND REGULATIONS.</small>		

PRIMARY DIMENSIONS ARE INCH
mm DIMENSIONS IN [BRACKETS]
ARE FOR REFERENCE ONLY

DRAWN BY VS	Regal Beloit America, Inc.	
DATE 12/02/2021	DESCRIPTION	
APPROVED BY GNK	OUTLINE 284/286TS FR NEMA ODP RS	
DATE 12/02/2021	MATERIAL	PROCESS/FINISH
REFERENCE	SIZE B	DRAWING NUMBER SS620709
THIRD ANGLE PROJECTION	SHEET 1 OF 1	



LOW VOLTAGE



HIGH VOLTAGE



VIEW OF TERMINAL END

DRAWING REVISION K	REVISION BY AJW	DATE 07-17-2015
ECO ECO-0081632	APPROVED BY T. VUE	DATE 07-17-2015
ECO DESCRIPTION REV'D IEC MARKINGS PER IEC 60034-8		
<small>COPYRIGHT REGAL BELOIT AMERICA, INC. ALL RIGHTS RESERVED. PROPRIETARY AND CONFIDENTIAL INFORMATION - THIS DOCUMENT IS THE PROPERTY OF REGAL BELOIT AMERICA, INC. ("OWNER") AND CONTAINS OWNER'S PROPRIETARY INFORMATION. ANY PERSON, CORPORATION OR OTHER FIRM RECEIVING IT IS DEEMED, BY RECEIVING IT, TO AGREE THAT IT, AND/OR ANY PART OF IT, SHALL NOT BE DISCLOSED TO ANY PERSON, CORPORATION OR OTHER ENTITY, DUPLICATED, AND/OR USED, EXCEPT AS EXPRESSLY APPROVED IN WRITING IN ADVANCE BY OWNER. THIS DOCUMENT SHALL BE RETURNED TO OWNER UPON REQUEST. IT MAY BE SUBJECT TO CERTAIN RESTRICTIONS UNDER APPLICABLE EXPORT CONTROL LAWS AND REGULATIONS.</small>		



DRAWN BY LZ
DATE 01-12-1994
APPROVED BY GK
DATE 01-14-1994
REFERENCE
THIRD ANGLE PROJECTION

Regal Beloit America, Inc.	
DESCRIPTION CONN DIAGRAM-EXTERNAL 3Ø-2/1 DELTA-12 LEADS	
MATERIAL	PROCESS/FINISH
SIZE A	DRAWING NUMBER EE7308AA
SHEET 1 OF 1	



P.O. BOX 8003
WAUSAU, WI 54401-8003
PH. 715-675-3311

DATA VOLTS: 460

CERTIFICATION DATA SHEET

CUSTOMER: _____ CUSTOMER P.O. #: _____
 ORDER #: _____ REFERENCE MODEL #: 284TSTDBD4007
 CONN. DIAGRAM: EE7308AA CAT #: U596
 OUTLINE: SS620709 CUSTOMER PART #: _____
 WINDING: IE3L1802110 NONE 3 MOUNTING: F1/F2 CAPABLE
 SPEED: _____

TYPICAL MOTOR PERFORMANCE DATA

HP	KW	SYNC RPM	FL RPM	FRAME	ENCLOSURE	TYPE	KVA CODE	DESIGN
30	22.4	3600	3560	284TS	DP	TDC	F	B

PH	HZ	VOLTS	AMPS	START TYPE	DUTY	INSL	S.F.	AMB	ELEV.
3	60	190/380	87/43.5	WS(LV ONLY) & YDRU	CONT	F	1.15	50	3300

F.L. EFF	91.0	3/4 LD EFF	91.0	1/2 LD EFF	89.5	GTD EFF	90.2	ELECT. TYPE	SQ CAGE IND RUN
F.L. PF	86.0	3/4 LD PF	82.0	1/2 LD PF	74.0				

F.L. TORQUE	LR AMPS @ 460 V	L.R. TORQUE	B.D. TORQUE	F.L. RISE (°C)
44.5 LB-FT	248	62.0 LB-FT 139%	110 LB-FT 247%	40

@ 3 FT.	POWER	ROTOR WK ²	MAX. LOAD WK ²	SAFE STALL TIME	STARTS/HOUR	MOTOR WGT
999 dBA	1008 dBA	0.00 LB-FT ²	0 LB-FT ²	20 SEC.	2	0 LB.

***** SUPPLEMENTAL INFORMATION *****

DE BRACKET TYPE	ODE BRACKET TYPE	MOUNT TYPE	MOTOR ORIENTATION	SEVERE DUTY	HAZARDOUS LOCATION	DRIP COVER	SCREENS	PAINT
STANDARD	STANDARD	RIGID	HORIZONTAL	NO	NONE	NO	NONE	RED (ENAMEL)

BEARINGS		GREASE	SHAFT TYPE	SPECIAL DE	SPECIAL ODE	SHAFT MATERIAL	FRAME MATERIAL
DE	ODE	POLYREX EM	TS	NONE	NONE	1045 HOT ROLLED (C-204)	ROLLED STEEL
BALL	BALL						
6211	6211						

THERMOSTATS	PROTECTORS	WDG RTD's	BRG RTD's	THERMISTORS	CONTROL	SPACE HEATERS
NONE	NOT	NONE	NONE	NONE	FALSE	NA

R1 (ohms/ph)	R2 (ohms/ph)	X1 (ohms/ph)	X2 (ohms/ph)	Xm (ohms/ph)	VIBRATION (in/sec)	FLOAT
0.155	0.065	0.458	0.516	14.241	0.150	ODE

* N O T E S *	INVERTER TORQUE: NONE					
	INV. HP SPEED RANGE: NONE					
	ENCODER: NONE					
	NONE					
	NONE NONE PPR					

PREPARED BY: FAREEDA DUDEKULA	BRAKE: NONE
DATE: 8/21/2018	NONE NONE
	FT-LB: NA
	VOLTAGE: NONE HZ:
	UL: NONE

FORM: 3531 REV_4 2/27/06

Data Sheet

284TSTDBD4007

Date: 12/12/2018
 Customer: _____
 Attention: _____
 Submitted by: FAREEDA DUDEKULA



Submittal

Data @ 380 V

Motor Load Data

Load	0%	25%	50%	75%	100%	115%	125%	LR
Current (Amps)	15.7	18.8	25.4	33.9	43.6	49.6	53.9	248
Torque (ft-lb)	0.00	11.0	22.0	33.0	44.5	51.0	55.5	62.0
RPM	3600	3590	3580	3570	3560	3,550	3545	0
Efficiency (%)		84.0	89.5	91.0	91.0	91.0	90.2	
P.F. (%)	8.0	54.0	74.0	82.0	86.0	87.0	87.0	36.0

Motor Speed Data

	LR	Pull-Up	BD	Rated	Idle
Speed (RPM)	0	1800	3350	3560	3600
Current (Amps)	248	218	151	43.6	15.7
Torque (ft-lb)	62.0	52.0	110	44.5	0.00

Information Block

HP	30.0			
Sync. RPM	3600			
Frame	284			
Enclosure	DP			
Construction	TDB			
Voltage	190/380 V			
Frequency	60 Hz			
Design	B			
LR Code letter	F			
Service Factor	1.15			
Temp Rise @ FL	40 °C			
Duty	CONT			
Ambient	40 °C			
Elevation	1,000 feet			
Rotor/Shaft wk ²	0.00 Lb-Ft ²			
Ref Wdg	IE3L1802110 NONE			
Sound Pressure @ 1M	999 dBA			
VFD Rating	NONE			
Outline Dwg	SS620709			
Conn. Diag	EE7308AA			
Additional Specifications:				
0				
0				
EQUIV CKT (OHMS / PHASE)				
R1	R2	X1	X2	Xm
0.1550	0.0650	0.4580	0.5160	14.2410

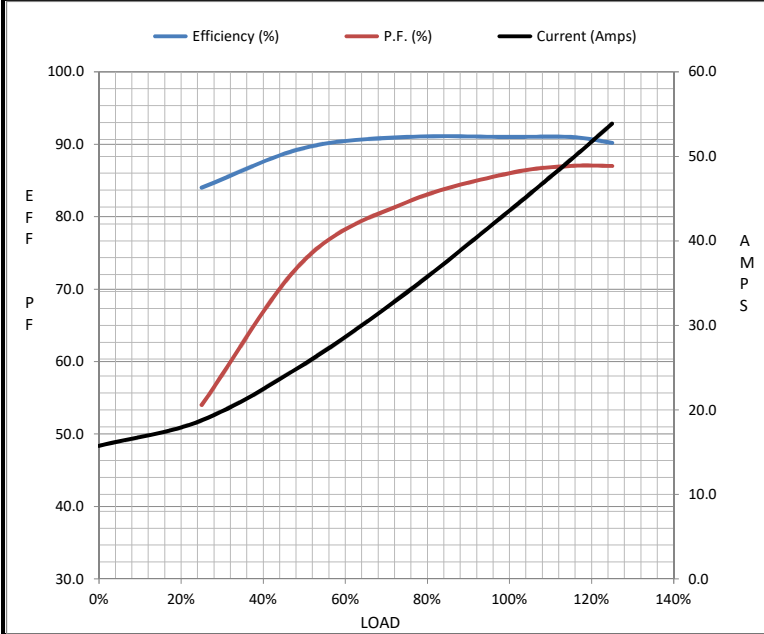

Speed - Torque Curve

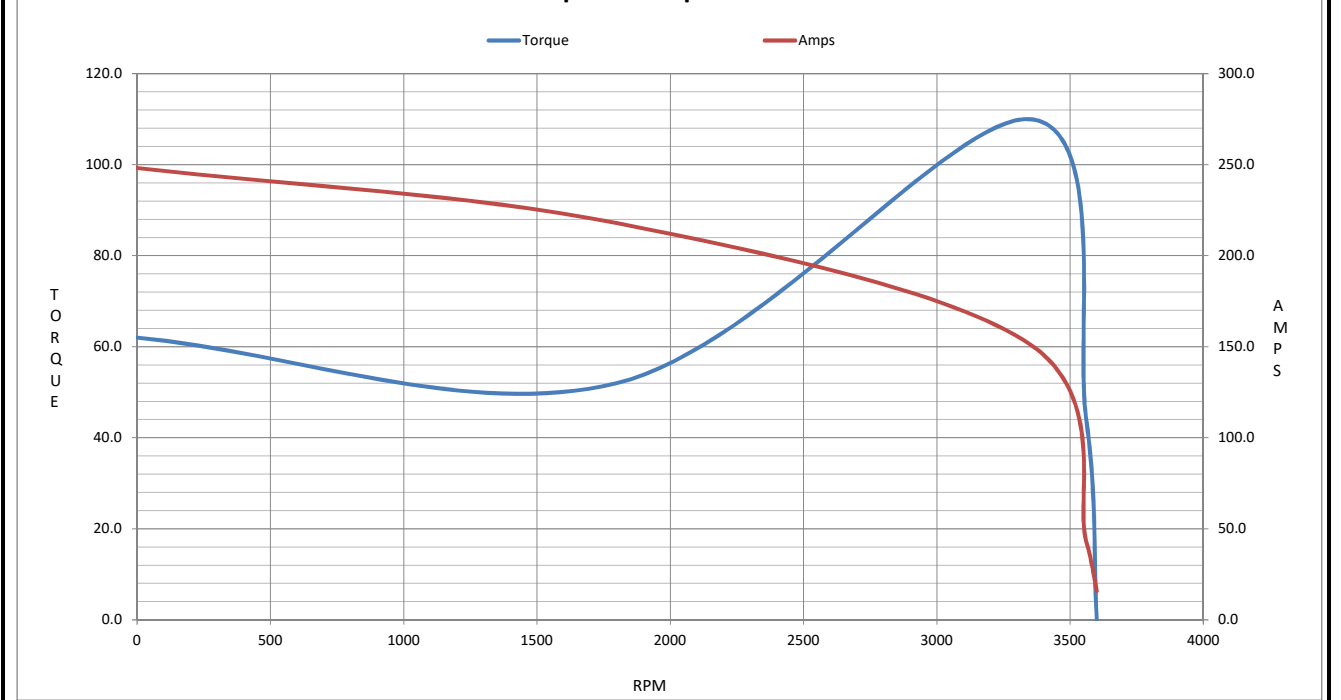

EC Declaration of Conformity

The undersigned representing
the manufacturer:

Regal Beloit America
100 East Randolph St.
Wausau, WI 54401

and the authorized representative
established within the Community:

Marathon Electric UK
6F Thistleton Road Ind. Estate
Market Overton
Oakham, Rutland LE15 7PP UK

are committed to providing customers with products that comply with applicable regulations and international protocols to which they are subject, including the requirements of the European Parliament Directive on the Harmonization of the laws relating to electrical equipment designed for use within certain voltage limits (2014/35/EU).

Regal Beloit America declares that the following product(s), to which this declaration relates, are in conformity with the relevant sections of the EC standards listed below.

This statement supersedes any statements previously issued pertaining to the product(s) listed below and is subject to change without notice.

Model No : 284TSTDBD4007

(Model No. may contain prefix and/or suffix characters)

Catalog No : U1053

Rework No : N/A

Directives :

Low Voltage Directive 2014/35/EU

Harmonized Standards Used :

EN 60034-1: 2010 (IEC 60034-1: 2010)

EN 60034-5: 2001/A1:2007 (IEC 60034-5: 2000/A1:2006)

Authorized Representative:



Michael A. Logsdon
Vice President, Technology

Authorized Representative in the Community:



Julian Clark
Marketing Engineer

Created on 09/01/2022

CE 22