

PRODUCT INFORMATION PACKET

Model No: 284TSHFNA9001

Catalog No: W558

Severe Duty Motor, 25 HP, 3 Ph, 60 Hz, 460 V, 3600 RPM, 284TS Frame, TEFC



Regal and are trademarks of Regal Rexnord Corporation or one of its affiliated companies.
©2022 Regal Rexnord Corporation, All Rights Reserved. MC017097E

Nameplate Specifications

Output HP	25 Hp	Output KW	18.7 kW
Frequency	60 Hz	Voltage	460 V
Current	28.8 A	Speed	3558 rpm
Service Factor	1.15	Phase	3
Efficiency	93 %	Power Factor	87.5
Duty	Continuous	Insulation Class	F
Design Code	B	KVA Code	G
Frame	284TS	Enclosure	Totally Enclosed Fan Cooled
Thermal Protection	No Protection	Ambient Temperature	40 °C
Drive End Bearing Size	6311	Opp Drive End Bearing Size	6210
UL	Recognized	CSA	Y
CE	Y	IP Code	56
Hazardous Location	DIVISION 2 T2B	Number of Speeds	1

Technical Specifications

Electrical Type	Squirrel Cage Inverter Rated	Starting Method	Line Or Inverter
Poles	2	Rotation	Reversible
Resistance Main	.0833 Ohms	Mounting	Rigid Base
Motor Orientation	Horizontal	Drive End Bearing	Ball
Opp Drive End Bearing	Ball	Frame Material	Cast Iron
Shaft Type	TS	Overall Length	25.06 in
Frame Length	12.75 in	Shaft Diameter	1.625 in
Shaft Extension	3.43 in	Assembly/Box Mounting	F1/F2 CAPABLE
Inverter Load	CONSTANT 20:1		
Outline Drawing	B-SS311136-1275	Connection Drawing	A-EE7300U

This is an uncontrolled document once printed or downloaded and is subject to change without notice. Date Created:10/10/2022

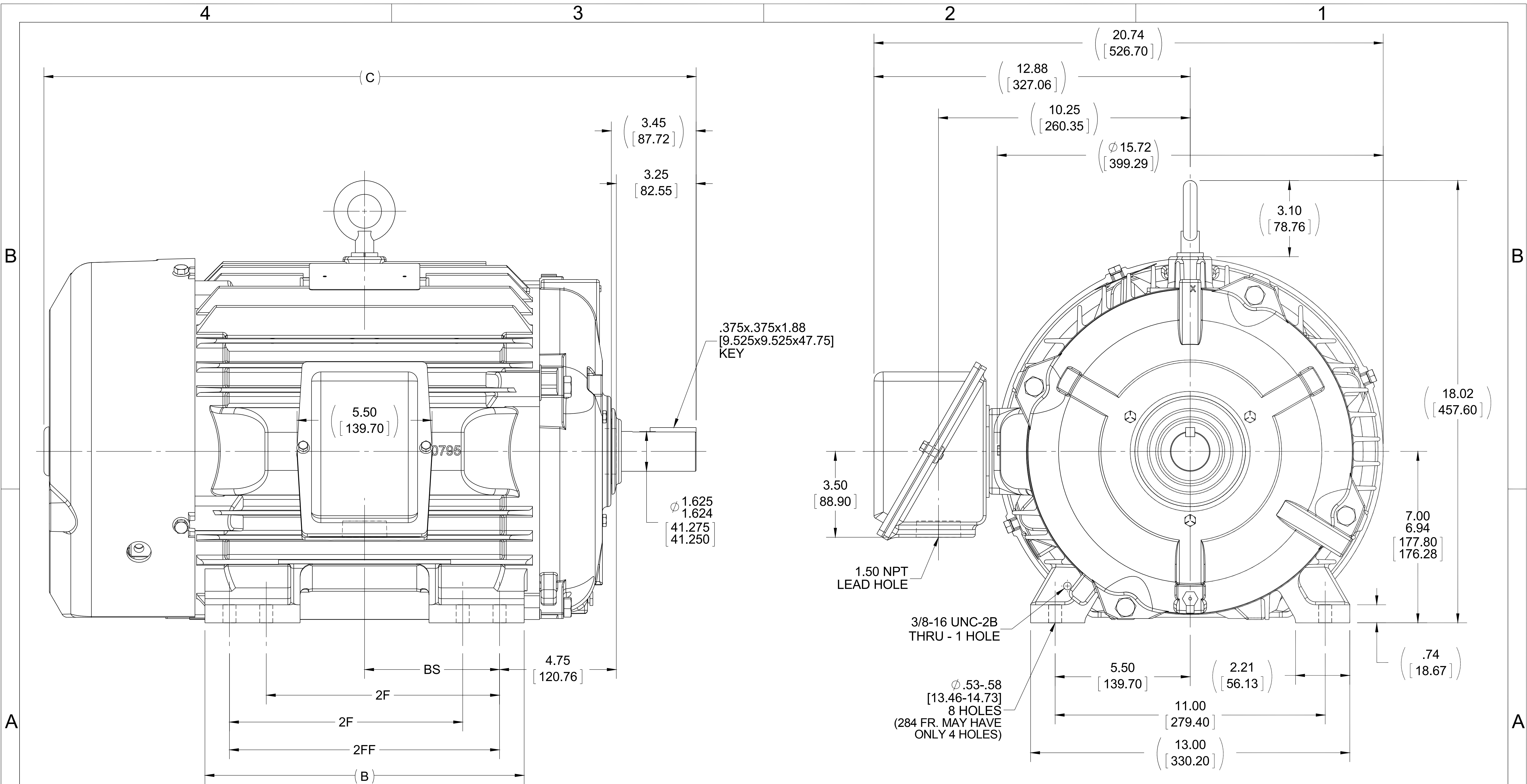

- NOTES:
 1. CONDUIT BOX CAN ONLY BE ROTATED CLOCKWISE UP TO 270° FROM ITS ORIGINAL POSITION.
 2. CONDUIT BOX CAN BE MOUNTED ON OPPOSITE SIDE BY REMOVING BRACKETS AND TURNING FRAME 180°.
 3. NAMEPLATE READ FROM CONDUIT BOX SIDE OF MOTOR.

1275	284TS	25.06 [636.53]	12.50 [317.50]	---	9.50 [241.30]	4.75 [120.65]
1425	284/286TS	26.56 [674.61]	13.00 [330.20]	9.50 [241.30]	11.00 [279.40]	5.50 [139.64]
DASH	FRAME	C	B	2F	2FF	BS
		4				

DRAWING REVISION F	REVISION BY MSG	DATE 11-10-2015
ECO ECO-0088479	APPROVED BY TVUE	DATE 11-11-2015
ECO DESCRIPTION UPDATED TO CURRENT STANDARDS		
<small>COPYRIGHT REGAL BELOIT AMERICA, INC. ALL RIGHTS RESERVED. PROPRIETARY AND CONFIDENTIAL INFORMATION - THIS DOCUMENT IS THE PROPERTY OF REGAL BELOIT AMERICA, INC. ("OWNER") AND CONTAINS OWNER'S PROPRIETARY INFORMATION. ANY PERSON, CORPORATION OR OTHER FIRM RECEIVING IT IS DEEMED, BY RECEIVING IT, TO AGREE THAT IT, AND/OR ANY PART OF IT, SHALL NOT BE DISCLOSED TO ANY PERSON, CORPORATION OR OTHER ENTITY, DUPLICATED, AND/OR USED, EXCEPT AS EXPRESSLY APPROVED IN WRITING IN ADVANCE BY OWNER. THIS DOCUMENT SHALL BE RETURNED TO OWNER UPON REQUEST. IT MAY BE SUBJECT TO CERTAIN RESTRICTIONS UNDER APPLICABLE EXPORT CONTROL LAWS AND REGULATIONS.</small>		

TOLERANCES UNLESS OTHERWISE SPECIFIED:

DEC.	INCH	mm	ANGLE
.X	±0.1	[±2.5]	±7° 30"
.XX	±0.03	[±0.76]	
.XXX	±0.005	[±0.127]	
.XXXX	±0.0005	[±0.0127]	

REMOVE BURRS & BREAK SHARP EDGES: .003/.015 [0.076/.381] X 45°
 CORNER FILLETS: R.02 [0.51]
 MACHINED SURFACES: 200 INCH/mm 5.1
 mm SHOWN IN [BRACKETS]

DRAWN BY DAH
DATE 04-02-2001
APPROVED BY ML
DATE 04-02-2001
REFERENCE
THIRD ANGLE PROJECTION

REGAL ™ Regal Beloit America, Inc.	
DESCRIPTION OUTLINE 280TS FR. - TEFC - STD. - 12.50 LAM	
MATERIAL	PROCESS/FINISH
SIZE B	DRAWING NUMBER SS311136
	SHEET 1 OF 1

IF MOTOR HAS 9 LEADS

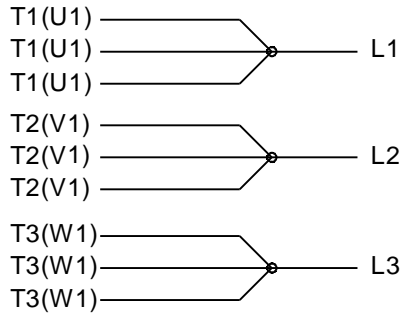

IF MOTOR HAS 6 LEADS

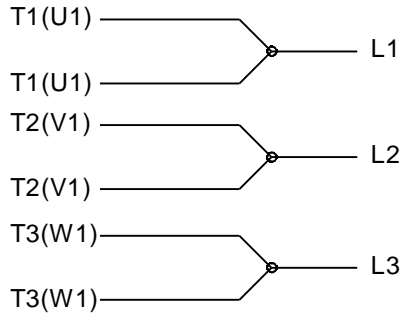

A-9806 DECAL IF CALLED FOR

IF MOTOR HAS 12 LEADS

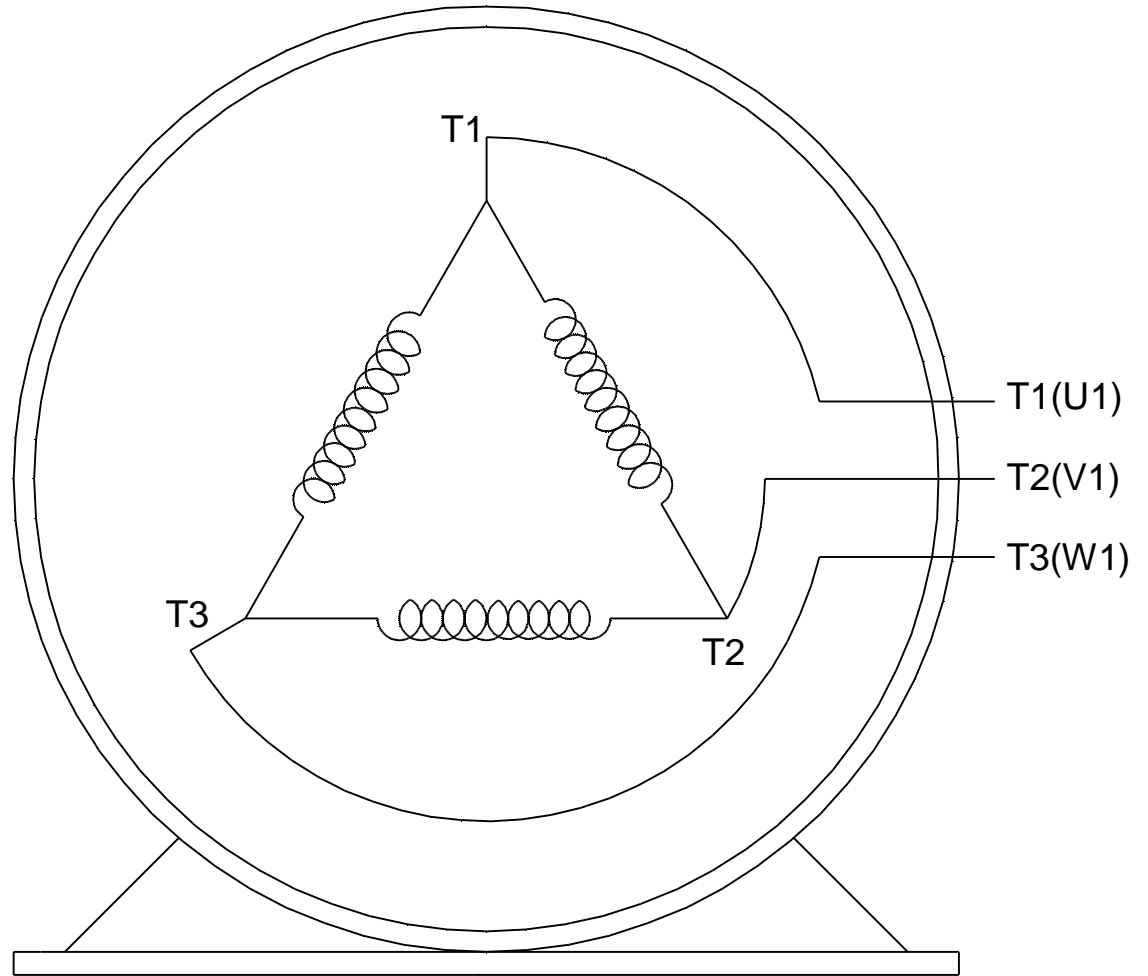
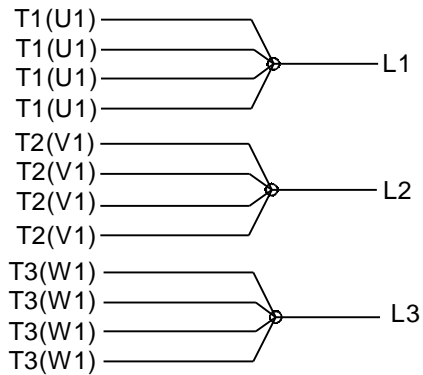

VIEW OF TERMINAL END

DRAWING REVISION L	REVISION BY AJW	DATE 05-04-2015	TOLERANCES UNLESS OTHERWISE SPECIFIED:	DRAWN BY DRS	Regal Beloit America, Inc.																					
ECO ECO-0077067	APPROVED BY EWH	DATE 05-05-2015	<table style="font-size: small; border-collapse: collapse;"> <tr> <td><u>DEC.</u></td> <td><u>INCH</u></td> <td><u>mm</u></td> <td><u>ANGLE</u></td> </tr> <tr> <td>.X</td> <td>±0.1</td> <td>[±2.5]</td> <td>±7' 30"</td> </tr> <tr> <td>.XX</td> <td>±0.02</td> <td>[±0.51]</td> <td></td> </tr> <tr> <td>.XXX</td> <td>±0.005</td> <td>[±0.127]</td> <td></td> </tr> <tr> <td>.XXXX</td> <td>±0.0005</td> <td>[±0.0127]</td> <td></td> </tr> </table>	<u>DEC.</u>			<u>INCH</u>	<u>mm</u>	<u>ANGLE</u>	.X	±0.1	[±2.5]	±7' 30"	.XX	±0.02	[±0.51]		.XXX	±0.005	[±0.127]		.XXXX	±0.0005	[±0.0127]		DATE 09-27-1996
<u>DEC.</u>	<u>INCH</u>	<u>mm</u>	<u>ANGLE</u>																							
.X	±0.1	[±2.5]	±7' 30"																							
.XX	±0.02	[±0.51]																								
.XXX	±0.005	[±0.127]																								
.XXXX	±0.0005	[±0.0127]																								
ECO DESCRIPTION UPDATED TO SOLIDWORKS <small>COPYRIGHT REGAL BELOIT AMERICA, INC. ALL RIGHTS RESERVED. PROPRIETARY AND CONFIDENTIAL INFORMATION - THIS DOCUMENT IS THE PROPERTY OF REGAL BELOIT AMERICA, INC. ("OWNER") AND CONTAINS OWNER'S PROPRIETARY INFORMATION. ANY PERSON, CORPORATION OR OTHER FIRM RECEIVING IT IS DEEMED, BY RECEIVING IT, TO AGREE THAT IT, AND/OR ANY PART OF IT, SHALL NOT BE DISCLOSED TO ANY PERSON, CORPORATION OR OTHER ENTITY, DUPLICATED, AND/OR USED, EXCEPT AS EXPRESSLY APPROVED IN WRITING IN ADVANCE BY OWNER. THIS DOCUMENT SHALL BE RETURNED TO OWNER UPON REQUEST. IT MAY BE SUBJECT TO CERTAIN RESTRICTIONS UNDER APPLICABLE EXPORT CONTROL LAWS AND REGULATIONS.</small>			APPROVED BY GK	MATERIAL _____ PROCESS/FINISH _____																						
			DATE 09-30-1996			REFERENCE	SIZE A	DRAWING NUMBER EE7300U	SHEET 1 OF 1																	
			REMOVE BURRS & BREAK SHARP EDGES: .003/.015 [.076/.381] X 45° CORNER FILLETS: R.02 [.51] MACHINED SURFACES: 200 $\sqrt{\text{INCH}}$ 5.1 $\sqrt{\text{mm}}$ mm SHOWN IN [BRACKETS]	THIRD ANGLE PROJECTION																						

CERTIFICATION DATA SHEET

Model#: 284TSHFNA9001 BB **WINDING#:** K284282 NONE 8
CONN. DIAGRAM: A-EE7300U **ASSEMBLY:** F1/F2 CAPABLE
OUTLINE: B-SS311136-1275

TYPICAL MOTOR PERFORMANCE DATA

HP	KW	SYNC. RPM	F.L. RPM	FRAME	ENCLOSURE	KVA CODE	DESIGN
25	18.7	3600	3558	284TS	TEFC	G	B

PH	Hz	VOLTS	FL AMPS	START TYPE	DUTY	INSL	S.F	AMB°C	ELEVATION
3	60	460	28.8	LINE OR INVERTER	CONTINUOU S	F3	1.15	40	3300

FULL LOAD EFF: 93	3/4 LOAD EFF: 93	1/2 LOAD EFF: 92.4	GTD. EFF	ELEC. TYPE	NO LOAD AMPS
FULL LOAD PF: 87.5	3/4 LOAD PF: 84	1/2 LOAD PF: 76	92.4	SQ CAGE INV RATED	10

F.L. TORQUE	LOCKED ROTOR AMPS	L.R. TORQUE	B.D. TORQUE	F.L. RISE°C
37 LB-FT	182	50 LB-FT 135	103 LB-FT 278	65

SOUND PRESSURE @ 3 FT.	SOUND POWER	ROTOR WK^2	MAX. WK^2	SAFE STALL TIME	STARTS /HOUR	APPROX. MOTOR WGT
72 dBA	82 dBA	2.3 LB-FT^2	32 LB-FT^2	20 SEC.	2	400 LBS.

***** SUPPLEMENTAL INFORMATION *****

DE BRACKET TYPE	ODE BRACKET TYPE	MOUNT TYPE	ORIENTATION	SEVERE DUTY	HAZARDOUS LOCATION	DRIP COVER	SCREENS	PAINT
STANDARD	STANDARD	RIGID	HORIZONTAL	PREMIUM SEVERE DUTY	DIVISION 2 T2B	FALSE	NONE	BLUE (EPOXY)

BEARINGS		GREASE	SHAFT TYPE	SPECIAL DE	SPECIAL ODE	SHAFT MATERIAL	FRAME MATERIAL
DE	OPE						
BALL	BALL	POLYREX EM	TS	NONE	NONE	1045 HOT ROLLED (C-204)	CAST IRON
6311	6210						

THERMO-PROTECTORS				THERMISTORS	CONTROL	SPACE /n HEATERS
THERMOSTATS	PROTECTORS	WDG RTDs	BRG RTDs			
NONE	NOT	NONE	NONE	NONE	FALSE	NONE VOLTS

If Inverter equals NONE, contact factory for further information

*
N
O
T
E
S
*

INVERTER TORQUE: CONSTANT 20:1
INV. HP SPEED RANGE: NONE
ENCODER: NONE
NONE NONE
NONE NONE PPR
BRAKE: NONE NONE
NONE P/N NONE
NONE NONE
NONE FT-LB NONE V NONE Hz

DATE: 06/21/2017 10:23:40 AM
 FORM 3531 REV.3 02/07/99
 ** Subject to change without notice.

Data Sheet

Date: 6/20/2017

Customer: _____

Attention: _____

Submitted by: FAREEDA DUDEKULA



284TSHFNA9001

Submittal

Data @ 460 V

Motor Load Data

Load	0%	25%	50%	75%	100%	115%	125%	LR
Current (Amps)	10.0	12.0	16.7	22.4	28.8	33.0	35.5	182
Torque (ft-lb)	0.00	9.0	18.5	27.5	37.0	42.0	46.5	50.0
RPM	3600	3590	3580	3570	3558	3,550	3545	0
Efficiency (%)		87.5	92.4	93.0	93.0	92.4	92.4	
P.F. (%)	6.0	55.0	76.0	84.0	87.5	88.5	89.0	31.0

Motor Speed Data

	LR	Pull-Up	BD	Rated	Idle
Speed (RPM)	0	1800	3350	3558	3600
Current (Amps)	182	167	118	28.8	10.0
Torque (ft-lb)	50.0	42.5	103	37.0	0.00

Information Block				
HP	25.0			
Sync. RPM	3600			
Frame	284			
Enclosure	TEFC			
Construction	TFN			
Voltage	460 V			
Frequency	60 Hz			
Design	A			
LR Code letter	G			
Service Factor	1.15			
Temp Rise @ FL	65 °C			
Duty	CONT			
Ambient	40 °C			
Elevation	1,000 feet			
Rotor/Shaft wk ²	2.30 Lb-Ft ²			
Ref Wdg	K284282 NONE			
Sound Pressure @ 1M	72 dBA			
VFD Rating	CONSTANT 20:1			
Outline Dwg	B-SS311136-1275			
Conn. Diag	A-EE7300U			
Additional Specifications:				
0				
0				
EQUIV CKT (OHMS / PHASE)				
R1	R2	X1	X2	Xm
0.0600	0.0280	0.2450	0.1600	6.9010

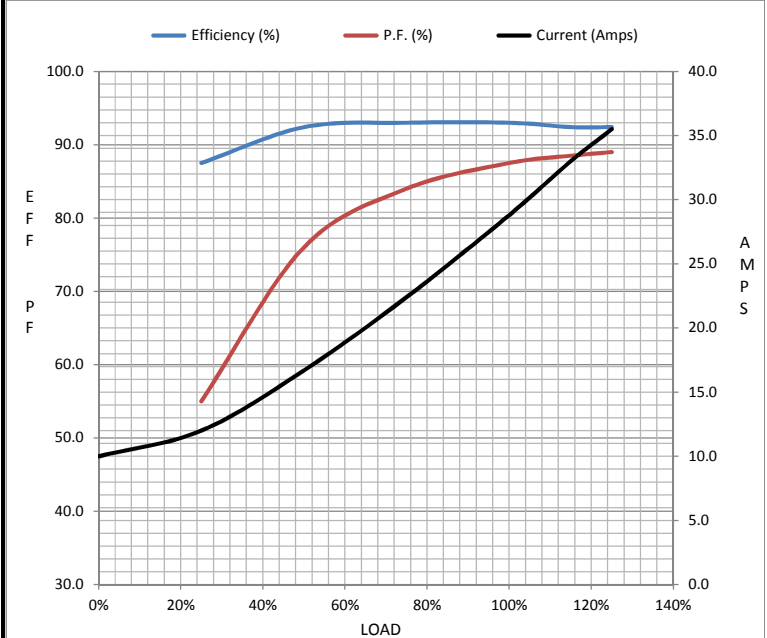

Speed - Torque Curve

