

# PRODUCT INFORMATION PACKET

Model No: 256TTFNA16825

Catalog No: U2140A

General Purpose Pump Motor, 20 & 15 HP, 3 Ph, 60 & 50 Hz, 230/460 & 190/380 V, 3600 & 3000 RPM,  
256 Frame, TEFC



Regal and Marathon are trademarks of Regal Rexnord Corporation or one of its affiliated companies.

©2023 Regal Rexnord Corporation, All Rights Reserved. MC017097E

### Nameplate Specifications

Phase	3	Output HP	20 & 15 Hp
Output KW	14.9 & 11.2 kW	Voltage	230/460 & 190/380 V
Speed	3537 & 2955 rpm	Service Factor	1.15 & 1.15
Frame	256	Enclosure	Totally Enclosed Fan Cooled
Thermal Protection	No Protection	Efficiency	92.4 & 92.4 %
Ambient Temperature	40 °C	Frequency	60 & 50 Hz
Current	47/23.4 & 42/21 A	Power Factor	86
Duty	Continuous	Insulation Class	F
Design Code	B	KVA Code	G
Drive End Bearing Size	6312	Opp Drive End Bearing Size	6210
UL	Recognized	CSA	Y
CE	Y	IP Code	55
Number of Speeds	1		

### Technical Specifications

Electrical Type	Squirrel Cage Inverter Rated	Starting Method	Line Or Inverter
Poles	2	Rotation	Reversible
Resistance Main	.394 Ohms	Mounting	Rigid Base
Motor Orientation	Horizontal	Drive End Bearing	Ball
Opp Drive End Bearing	Ball	Frame Material	Cast Iron
Shaft Type	Hyd Pump Adaptor Shaft	Overall Length	23.09 in
Frame Length	12.25 in	Shaft Diameter	1.750 in
Shaft Extension	4 in	Assembly/Box Mounting	F1/F2 Capable
Outline Drawing	B-SS208429-1225	Connection Drawing	A-EE7308

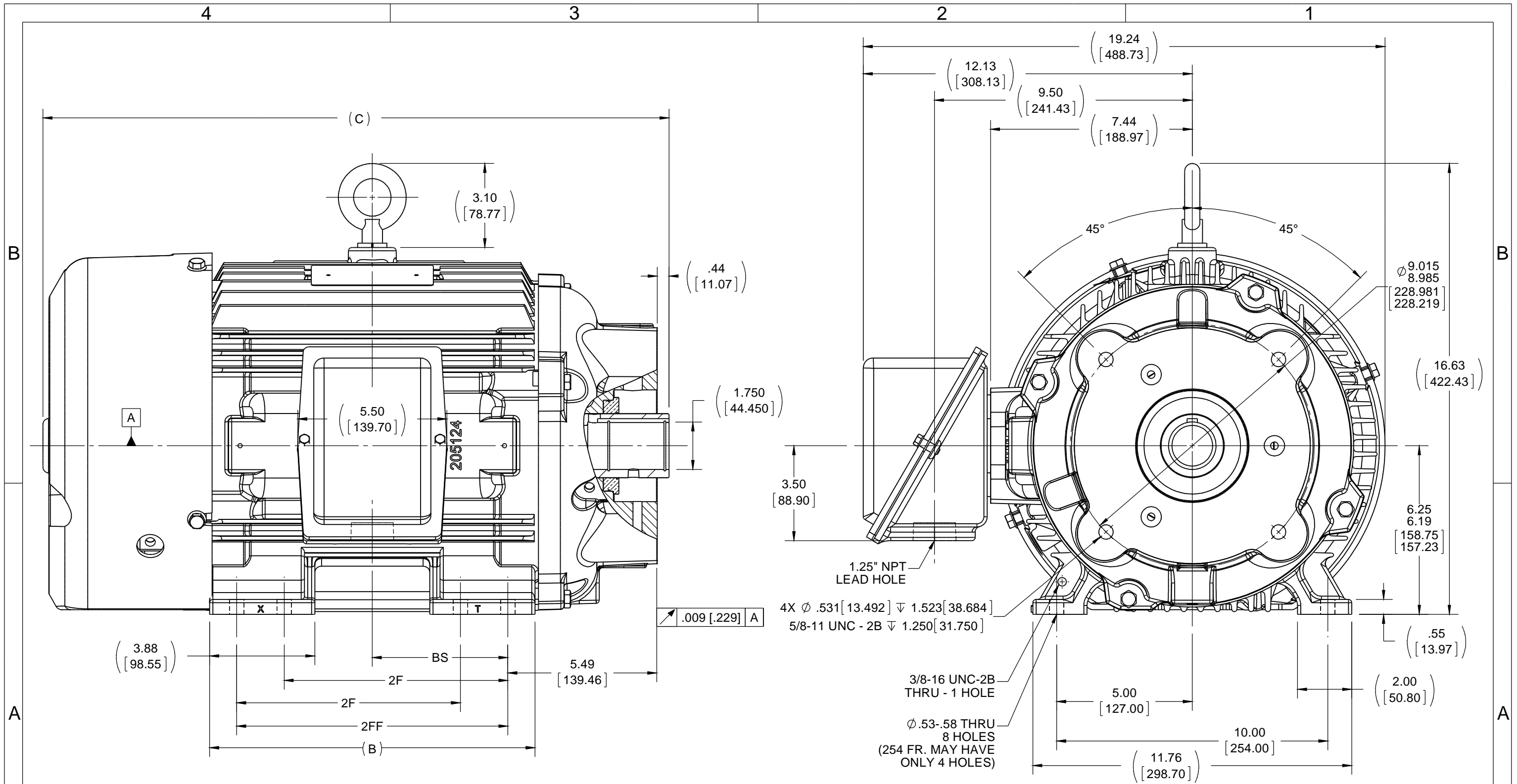

- NOTES:  
 1. CONDUIT BOX CAN BE ROTATED IN 90° STEPS.  
 2. NAMEPLATE READ FROM CONDUIT BOX SIDE OF MOTOR.

DRAWING REVISION A	REVISION BY	DATE	TOLERANCES UNLESS OTHERWISE SPECIFIED:		DRAWN BY D.FROEHLICH	Regal Beloit America, Inc.
ECO ECO-0071663	APPROVED BY	DATE	DEC.	INCH	DATE 02-10-2015	
ECO DESCRIPTION MU119319, NMR-0078152			.X	±0.1	DESCRIPTION OUTLINE	
COPYRIGHT REGAL BELOIT AMERICA, INC. ALL RIGHTS RESERVED. PROPRIETARY AND CONFIDENTIAL INFORMATION - THIS DOCUMENT IS THE PROPERTY OF REGAL BELOIT AMERICA, INC. ("OWNER") AND CONTAINS OWNER'S PROPRIETARY INFORMATION. ANY PERSON, CORPORATION OR OTHER FIRM RECEIVING IT IS DEEMED, BY RECEIVING IT, TO AGREE THAT IT, AND/OR ANY PART OF IT, SHALL NOT BE DISCLOSED TO ANY PERSON, CORPORATION OR OTHER ENTITY, DUPLICATED, AND/OR USED, EXCEPT AS EXPRESSLY APPROVED IN WRITING IN ADVANCE BY OWNER. THIS DOCUMENT SHALL BE RETURNED TO OWNER UPON REQUEST. IT MAY BE SUBJECT TO CERTAIN RESTRICTIONS UNDER APPLICABLE EXPORT CONTROL LAWS AND REGULATIONS.			.XX	±0.03	DATE 02-10-2015	
			.XXX	±0.005	REFERENCE	MATERIAL
			.XXXX	±0.0005	THIRD ANGLE PROJECTION	SIZE B
			REMOVE BURRS & BREAK SHARP EDGES: .003/.015 [0.076/.381] CORNER FILLETS: .02 [0.51] MACHINED SURFACES: 200 INCH/mm 5.1 mm SHOWN IN [BRACKETS]		DRAWING NUMBER SS208429	SHEET 1 OF 1

1050	254TYZ	21.34 [542.04]	10.25 [260.35]	---	8.25 [209.55]	4.13 [104.90]
1225	254/256TYZ	23.09 [586.49]	12.00 [304.80]	8.25 [209.55]	10.00 [254.00]	5.00 [127.00]
DASH	FRAME	C	B	2F	2FF	BS

EE7308

THREE PHASE  
DUAL VOLTAGE MOTOR

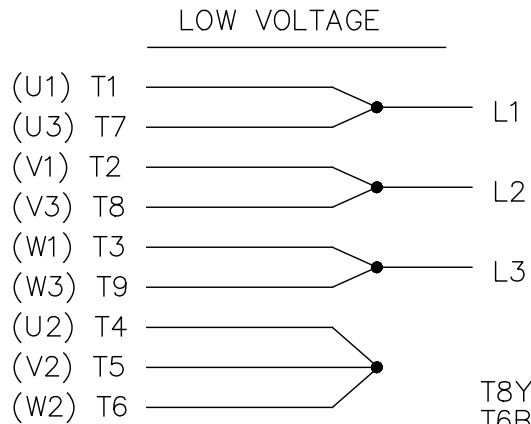
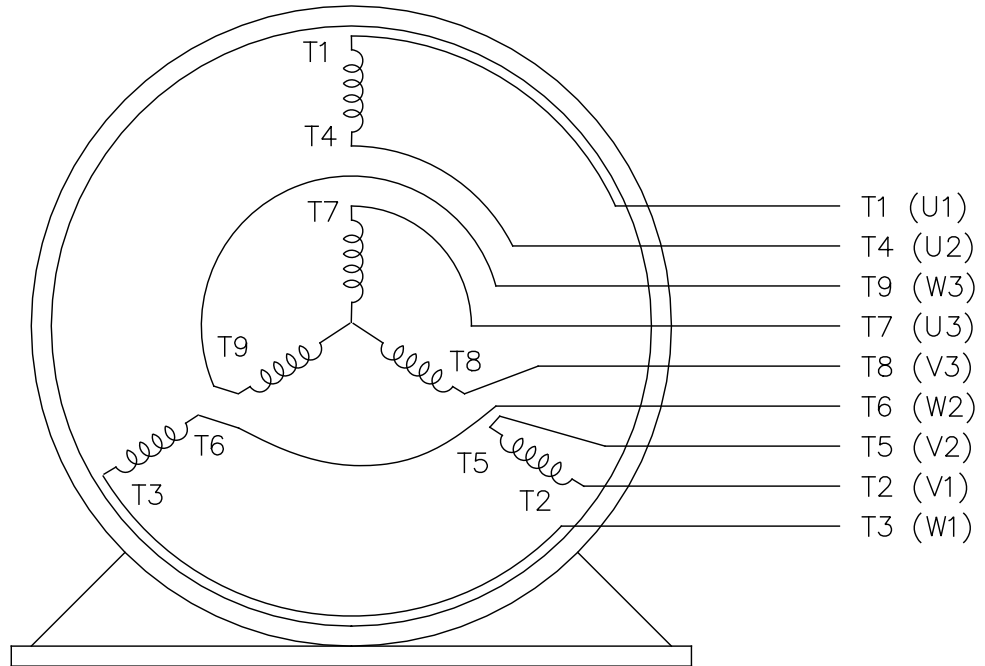

VIEW OF TERMINAL END

REF.  
WINDING DIAGRAM

T8Y, T2Y, T2BL, T4BX, T2EC, T2G  
T6BZ, T2B, T6BL, T4AV, T6B, T4B

OPTIONAL CORD  
CONNECTION

L1 — WHITE  
L2 — RED  
L3 — BLACK

NO.	REVISION	BY & DATE	CHK	ANG	TOLERANCES UNLESS SPECIFIED		FINISH	DRAWN RM 11/20/1990				
					DEC.	INCHES						
5	CHG TO REGAL LOGO	SL 09/10/2015	AB					CHK ML 11/21/1990				
4	REVISED IEC NOTATIONS	MSG 11/15/2011	CMN	.X	±.1			APPD SAS 04/24/2003				
3	ADDED IEC NOTATIONS... (U1), (V1) ETC. MU95194	MSG 5/10/2010	MJS	.XX	±.02		TITLE CONNECTION DIAGRAM	SCALE 1=1				
2	ADDED THE OPTIONAL CORD CONNECTION MU46318	RDH 04/24/2003	DRS	.XXX	±.005		3Ø - DUAL VOLTAGE MOTOR	REF				
1	REDRAWN	RM 11/20/1990		.XXXX	±.0005		MAT'L.	FMF				
					±7'30"			PREV				
THIS DRAWING IN DESIGN AND DETAIL IS OUR PROPERTY AND MUST NOT BE USED EXCEPT IN CONNECTION WITH OUR WORK ALL RIGHTS OF DESIGN AND INVENTION ARE RESERVED THIS IS AN ELECTRONICALLY GENERATED DOCUMENT - DO NOT SCALE THIS PRINT							RFP	CAD FILE ee7308	SIZE A	DRAWING NO. EE7308	PAGE OF 5	REV. 5
							DIST WP					



Regal Beloit America, Inc.

**CERTIFICATION DATA SHEET**

**Model#:** 256TTFNA16825 AA  
**CONN. DIAGRAM:** A-EE7308  
**OUTLINE:** B-SS208429-1225

**WINDING#:** K256288 NONE 10  
**ASSEMBLY:** F1/F2 CAPABLE

**TYPICAL MOTOR PERFORMANCE DATA**

HP	KW	SYNC. RPM	F.L. RPM	FRAME	ENCLOSURE	KVA CODE	DESIGN
20&15	14.9&11.2	3600	3537&2955	256	TEFC	G	B

PH	Hz	VOLTS	FL AMPS	START TYPE	DUTY	INSL	S.F	AMB°C	ELEVATION
3	60/50	230/460#190/ 380	47/23.4&42/21	LINE OR INVERTER	CONTINUOU S	F3	1.15/1.15	40	3300

FULL LOAD EFF: 92.4&92.4	3/4 LOAD EFF: 91.7	1/2 LOAD EFF: 91	GTD. EFF	ELEC. TYPE	NO LOAD AMPS
FULL LOAD PF: 86&86.5	3/4 LOAD PF: 85	1/2 LOAD PF: 78	91.7	SQ CAGE INV RATED	14 / 7

F.L. TORQUE	LOCKED ROTOR AMPS	L.R. TORQUE	B.D. TORQUE	F.L. RISE°C
29.7 LB-FT	290 / 145	55 LB-FT 185	84 LB-FT 283	55

SOUND PRESSURE @ 3 FT.	SOUND POWER	ROTOR WK^2	MAX. WK^2	SAFE STALL TIME	STARTS /HOUR	APPROX. MOTOR WGT
72 dBA	82 dBA	1.3 LB-FT^2	26 LB-FT^2	20 SEC.	2	370 LBS.

**\*\*\* SUPPLEMENTAL INFORMATION \*\*\***

DE BRACKET TYPE	ODE BRACKET TYPE	MOUNT TYPE	ORIENTATION	SEVERE DUTY	HAZARDOUS LOCATION	DRIP COVER	SCREENS	PAINT
HYD PUMP SAE MOUNT PAD	STANDARD	RIGID	HORIZONTAL	PREMIUM SEVERE DUTY	NONE	FALSE	NONE	BLUE (EPOXY)

BEARINGS		GREASE	SHAFT TYPE	SPECIAL DE	SPECIAL ODE	SHAFT MATERIAL	FRAME MATERIAL
DE	OPE						
BALL	BALL	POLYREX EM	HYD PUMP ADAPTOR SHAFT	NONE	NONE	1045 HOT ROLLED (C-204)	CAST IRON
6312	6210						

THERMO-PROTECTORS				THERMISTORS	CONTROL	SPACE /n HEATERS
THERMOSTATS	PROTECTORS	WDG RTDs	BRG RTDs			
NONE	NOT	NONE	NONE	NONE	FALSE	NONE VOLTS

If Inverter equals NONE, contact factory for further information

\*  
N  
O  
T  
E  
S  
\*

INVERTER TORQUE: CONSTANT 10:1 INV. HP SPEED RANGE: NONE
ENCODER: NONE NONE NONE NONE NONE PPR
BRAKE: NONE NONE NONE P/N NONE NONE NONE NONE FT-LB NONE V NONE Hz

DATE: 06/23/2017 07:09:14 AM  
 FORM 3531 REV.3 02/07/99

\*\* Subject to change without notice.

Data Sheet

Date: 6/20/2017

Customer: \_\_\_\_\_

Attention: \_\_\_\_\_

Submitted by: FAREEDA DUDEKULA



256TTFNA16825

Submittal

Data @ 460 V

Motor Load Data

Load	0%	25%	50%	75%	100%	115%	125%	LR
Current (Amps)	7.0	9.0	13.0	18.0	23.4	26.0	29.5	145
Torque (ft-lb)	0.00	7.5	15.0	22.0	29.7	31.0	37.5	55.0
RPM	3600	3585	3570	3555	3537	3,525	3515	0
Efficiency (%)		87.5	91.0	91.7	92.4	91.7	90.2	
P.F. (%)	10.5	58.5	78.0	85.0	86.0	87.0	88.5	37.0

Motor Speed Data

	LR	Pull-Up	BD	Rated	Idle
Speed (RPM)	0	1800	3155	3537	3600
Current (Amps)	145	131	100	23.4	7.0
Torque (ft-lb)	55.0	50.0	84.0	29.7	0.00

Information Block

HP	20.0
Sync. RPM	3600
Frame	256
Enclosure	TEFC
Construction	TFN
Voltage	30/460#190/381V
Frequency	60 Hz
Design	B
LR Code letter	G
Service Factor	1.15
Temp Rise @ FL	55 °C
Duty	CONT
Ambient	40 °C
Elevation	1,000 feet
Rotor/Shaft wk <sup>2</sup>	1.30 Lb-Ft <sup>2</sup>
Ref Wdg	K256288 NONE
Sound Pressure @ 1M	72 dBA
VFD Rating	CONSTANT 10:1
Outline Dwg	B-SS208429-1225
Conn. Diag	A-EE7308

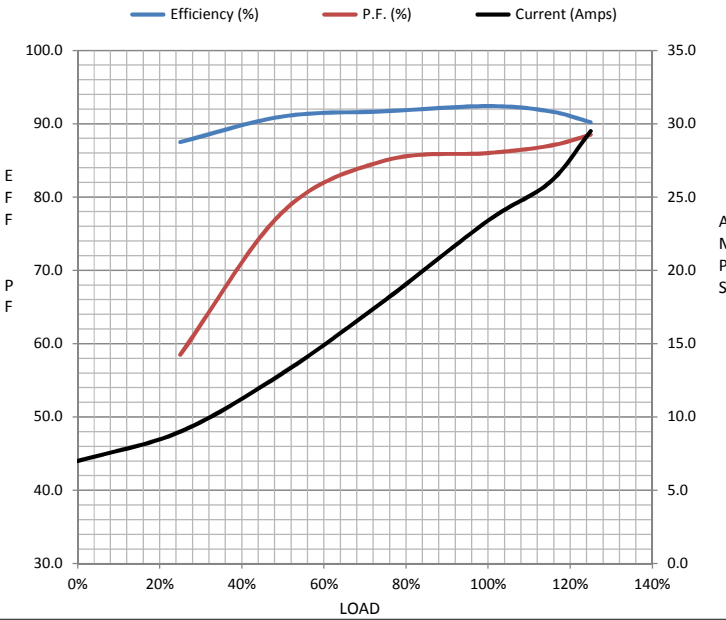

Additional Specifications:

0

0

EQUIV CKT (OHMS / PHASE)

R1	R2	X1	X2	Xm
0.2530	0.2230	1.0790	1.1190	37.7720

Speed -Torque Curve

