

# PRODUCT INFORMATION PACKET

Model No: 256TTFL16076

Catalog No: E2120

XRI® General Purpose General Purpose Motor, 10 & 10 HP, 3 Ph, 60 & 50 Hz, 230/460 & 190/380 V,  
1200 & 1000 RPM, 256T Frame, TEFC



Regal and Marathon are trademarks of Regal Rexnord Corporation or one of its affiliated companies.

©2023 Regal Rexnord Corporation, All Rights Reserved. MC017097E

### Nameplate Specifications

Phase	<b>3</b>	Output HP	<b>10 &amp; 10 Hp</b>
Output KW	<b>7.5 &amp; 7.5 kW</b>	Voltage	<b>230/460 &amp; 190/380 V</b>
Speed	<b>1176 &amp; 965 rpm</b>	Service Factor	<b>1.15 &amp; 1.15</b>
Frame	<b>256T</b>	Enclosure	<b>Totally Enclosed Fan Cooled</b>
Thermal Protection	<b>No Protection</b>	Efficiency	<b>91 &amp; 89.5 %</b>
Ambient Temperature	<b>40 °C</b>	Frequency	<b>60 &amp; 50 Hz</b>
Current	<b>26.2/13.1 &amp; 31/15.5 A</b>	Power Factor	<b>79</b>
Duty	<b>Continuous</b>	Insulation Class	<b>F</b>
Design Code	<b>B</b>	KVA Code	<b>H</b>
Drive End Bearing Size	<b>6309</b>	Opp Drive End Bearing Size	<b>6208</b>
UL	<b>Recognized</b>	CSA	<b>Y</b>
CE	<b>Y</b>	IP Code	<b>43</b>
Number of Speeds	<b>1</b>		

### Technical Specifications

Electrical Type	<b>Squirrel Cage Inverter Rated</b>	Starting Method	<b>Line Or Inverter</b>
Poles	<b>6</b>	Rotation	<b>Reversible</b>
Resistance Main	<b>.934 Ohms</b>	Mounting	<b>Rigid Base</b>
Motor Orientation	<b>Horizontal</b>	Drive End Bearing	<b>Ball</b>
Opp Drive End Bearing	<b>Ball</b>	Frame Material	<b>Aluminum</b>
Shaft Type	<b>T</b>	Overall Length	<b>25.26 in</b>
Frame Length	<b>13.75 in</b>	Shaft Diameter	<b>1.625 in</b>
Shaft Extension	<b>4.38 in</b>	Assembly/Box Mounting	<b>F1 ONLY</b>
Connection Drawing	<b>A-EE7308</b>	Outline Drawing	<b>B-SS321100-1375</b>

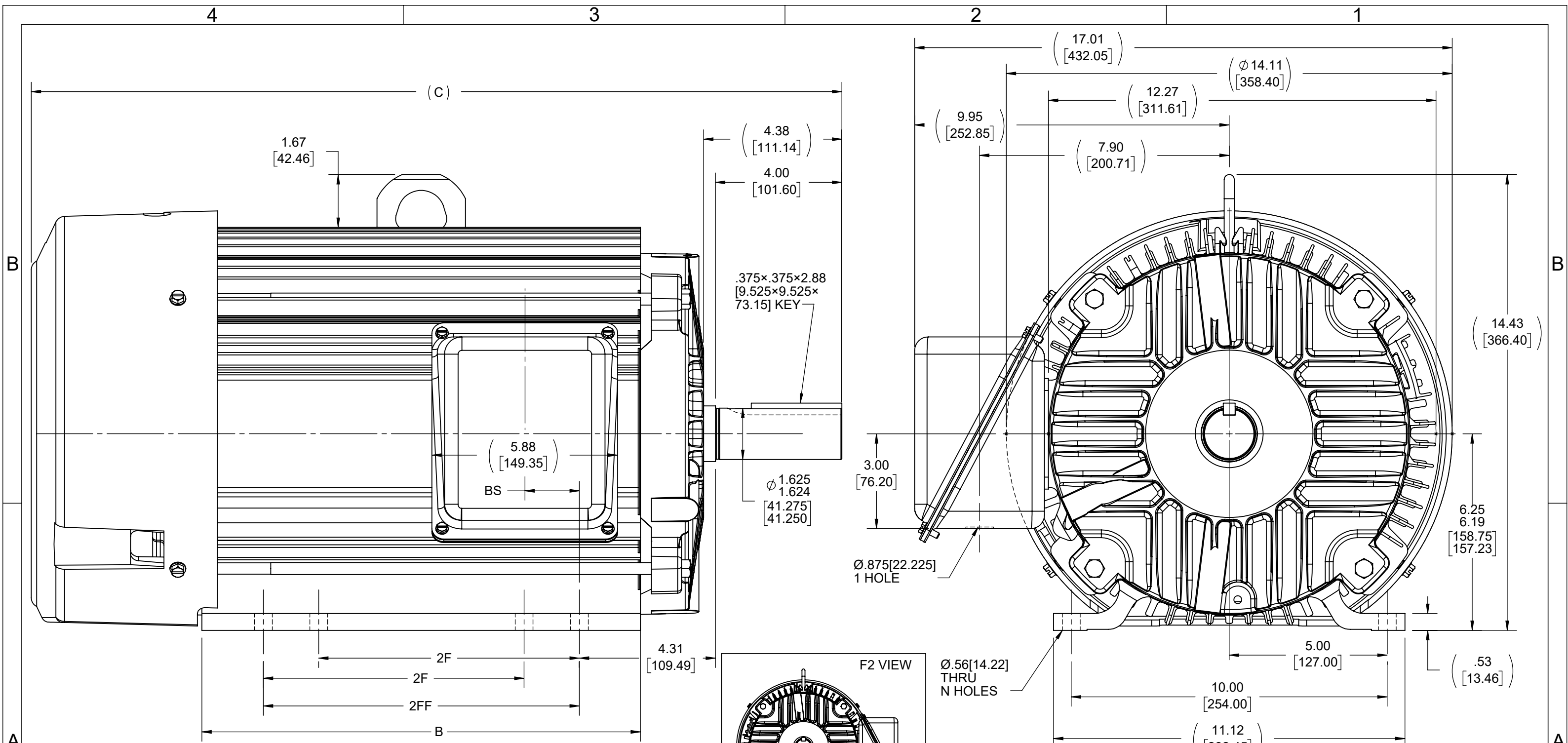

- NOTES:  
 1. CONDUIT BOX CAN BE ROTATED IN 90° STEPS.  
 2. NAMEPLATES TO BE READ FROM CONDUIT BOX SIDE OF MOTOR.

DASH	FRAME	C	B	2F	2FF	BS	N
1200	254T	23.78 [603.90]	12.13 [308.10]	8.25 [209.55]	-----	1.73 [43.94]	4
1375	254/6T	25.66 [651.65]	13.88 [352.55]	8.25 [209.55]	10.00 [254.00]	1.73 [43.94]	8

DRAWING REVISION D	REVISION BY SP	DATE 05-26-2021
ECO CR-0001205	APPROVED BY AS	DATE 05-26-2021
ECO DESCRIPTION REPLACED FAN GUARD 3C223-E3 TO 205016B		
<small>COPYRIGHT REGAL BELOIT AMERICA, INC. ALL RIGHTS RESERVED          PROPRIETARY AND CONFIDENTIAL INFORMATION - THIS DOCUMENT IS THE PROPERTY OF          REGAL BELOIT AMERICA, INC. ("OWNER") AND CONTAINS OWNER'S PROPRIETARY          INFORMATION. ANY PERSON, CORPORATION OR OTHER FIRM RECEIVING IT IS DEEMED,          BY RECEIVING IT, TO AGREE THAT IT, AND/OR ANY PART OF IT, SHALL NOT BE DISCLOSED          TO ANY PERSON, CORPORATION OR OTHER ENTITY, DUPLICATED, AND/OR USED, EXCEPT          AS EXPRESSLY APPROVED IN WRITING IN ADVANCE BY OWNER. THIS DOCUMENT SHALL          BE RETURNED TO OWNER UPON REQUEST. IT MAY BE SUBJECT TO CERTAIN          RESTRICTIONS UNDER APPLICABLE EXPORT CONTROL LAWS AND REGULATIONS.</small>		

TOLERANCES UNLESS OTHERWISE SPECIFIED:  
 DEC. INCH mm ANGLE  
 .X ±0.1 [±2.5]  
 .XX ±0.03 [±0.76]  
 .XXX ±0.005 [±0.127]  
 .XXXX ±0.0005 [±0.0127]  
 REMOVE BURRS & BREAK SHARP EDGES: .003/.015 [0.076/.381] X 45°  
 CORNER FILLETS: R.02 [51]  
 MACHINED SURFACES: 200 INCH mm 5.1  
 mm SHOWN IN [BRACKETS]

DRAWN BY  
RJW  
DATE  
02-01-2005  
APPROVED BY  
BW  
DATE  
02-01-2005  
REFERENCE  
THIRD ANGLE PROJECTION

**REGAL**™ Regal Beloit America, Inc.

DESCRIPTION  
**OUTLINE**  
250T FR.-ALUM. FR.-TEFC

MATERIAL PROCESS/FINISH

SIZE DRAWING NUMBER SHEET  
B SS321100 1 OF 1



NO.	REVISION	BY & DATE	CHK	ANG	TOLERANCES UNLESS SPECIFIED		FINISH	DRAWN RM	ML	REV.	
					DEC.	INCHES					
5	CHG TO REGAL LOGO	SL 09/10/2015	AB					RM	11/20/1990		
4	REVISED IEC NOTATIONS	MSG 11/15/2011	CMN	.X	±.1			CHK	ML 11/21/1990		
3	ADDED IEC NOTATIONS... (U1), (V1) ETC. MU95194	MSG 5/10/2010	MJS	.XX	±.02			APPD	SAS 04/24/2003		
2	ADDED THE OPTIONAL CORD CONNECTION MU46318	RDH 04/24/2003	DRS	.XXX	±.005			SCALE	1=1		
1	REDRAWN	RM 11/20/1990		.XXXX	±.0005			REF			
					±7'30"			FMP			
THIS DRAWING IN DESIGN AND DETAIL IS OUR PROPERTY AND MUST NOT BE USED EXCEPT IN CONNECTION WITH OUR WORK ALL RIGHTS OF DESIGN AND INVENTION ARE RESERVED THIS IS AN ELECTRONICALLY GENERATED DOCUMENT - DO NOT SCALE THIS PRINT							RFP	CAD FILE ee7308	SIZE	DRAWING NO. PAGE OF	REV.
							DIST WP		A	EE7308	5

**CERTIFICATION DATA SHEET**

**Model#:** 256TTFL16076 AN  
**CONN. DIAGRAM:** A-EE7308  
**OUTLINE:** B-SS321100-1375

**WINDING#:** 256674 R16 6  
**ASSEMBLY:** F1 ONLY

**TYPICAL MOTOR PERFORMANCE DATA**

HP	KW	SYNC. RPM	F.L. RPM	FRAME	ENCLOSURE	KVA CODE	DESIGN
10&10	7.5&7.5	1200	1176&965	256T	TEFC	H	B

PH	Hz	VOLTS	FL AMPS	START TYPE	DUTY	INSL	S.F	AMB°C	ELEVATION
3	60/50	230/460#190/ 380	26.2/13.1&31/ 15.5	LINE OR INVERTER	CONTINUOU S	F3	1.15/1.15	40	3300

FULL LOAD EFF: 91&89.5	3/4 LOAD EFF: 91	1/2 LOAD EFF: 90.2	GTD. EFF	ELEC. TYPE	NO LOAD AMPS
FULL LOAD PF: 79&82	3/4 LOAD PF: 72.5	1/2 LOAD PF: 61	90.2	SQ CAGE INV RATED	13 / 6.5

F.L. TORQUE	LOCKED ROTOR AMPS	L.R. TORQUE	B.D. TORQUE	F.L. RISE°C
44.7 LB-FT	162 / 81	92 LB-FT 206	139 LB-FT 311	40

SOUND PRESSURE @ 3 FT.	SOUND POWER	ROTOR WK^2	MAX. WK^2	SAFE STALL TIME	STARTS /HOUR	APPROX. MOTOR WGT
56 dBA	66 dBA	3 LB-FT^2	225 LB-FT^2	20 SEC.	2	450 LBS.

**\*\*\* SUPPLEMENTAL INFORMATION \*\*\***

DE BRACKET TYPE	ODE BRACKET TYPE	MOUNT TYPE	ORIENTATION	SEVERE DUTY	HAZARDOUS LOCATION	DRIP COVER	SCREENS	PAINT
STANDARD	STANDARD	RIGID	HORIZONTAL	FALSE	NONE	FALSE	NONE	BLUE (ENAMEL)

BEARINGS		GREASE	SHAFT TYPE	SPECIAL DE	SPECIAL ODE	SHAFT MATERIAL	FRAME MATERIAL
DE	OPE						
BALL	BALL	POLYREX EM	T	NONE	NONE	1045 HOT ROLLED (C-204)	ALUMINUM
6309	6208						

THERMO-PROTECTORS				THERMISTORS	CONTROL	SPACE /n HEATERS
THERMOSTATS	PROTECTORS	WDG RTDs	BRG RTDs			
NONE	NOT	NONE	NONE	NONE	FALSE	NONE VOLTS

If Inverter equals NONE, contact factory for further information

\*  
N  
O  
T  
E  
S  
\*

INVERTER TORQUE: CONSTANT 10:1
INV. HP SPEED RANGE: NONE
ENCODER: NONE
NONE NONE
NONE NONE PPR
BRAKE: NONE NONE
NONE P/N NONE
NONE NONE
- FT-LB NONE V NONE Hz

DATE: 06/23/2017 07:06:33 AM  
 FORM 3531 REV.3 02/07/99  
 \*\* Subject to change without notice.

Data Sheet

Date: 6/19/2017

Customer: \_\_\_\_\_

Attention: \_\_\_\_\_

Submitted by: FAREEDA DUDEKULA



256TTFL16076

Submittal

Data @ 460 V

Motor Load Data

Load	0%	25%	50%	75%	100%	115%	125%	LR
Current (Amps)	6.5	7.0	8.5	10.5	13.1	15.0	16.0	81.0
Torque (ft-lb)	0.00	11.0	22.0	33.5	44.7	51.0	56.0	92.0
RPM	1200	1195	1190	1180	1176	1,170	1165	0
Efficiency (%)		84.0	90.2	91.0	91.0	90.2	89.5	
P.F. (%)	5.5	39.5	61.0	72.5	79.0	80.0	81.5	41.0

Motor Speed Data

	LR	Pull-Up	BD	Rated	Idle
Speed (RPM)	0	400	1055	1176	1200
Current (Amps)	81.0	78.0	53.5	13.1	6.5
Torque (ft-lb)	92.0	86.0	139	44.7	0.00

Information Block

HP	10.0			
Sync. RPM	1200			
Frame	256			
Enclosure	TEFC			
Construction	TFY			
Voltage	30/460#190/381V			
Frequency	60 Hz			
Design	B			
LR Code letter	H			
Service Factor	1.15			
Temp Rise @ FL	40 °C			
Duty	CONT			
Ambient	40 °C			
Elevation	1,000 feet			
Rotor/Shaft wk <sup>2</sup>	3.0 Lb-Ft <sup>2</sup>			
Ref Wdg	256674 R16			
Sound Pressure @ 1M	56 dBA			
VFD Rating	CONSTANT 10:1			
Outline Dwg	B-SS321100-1375			
Conn. Diag	A-EE7308			
Additional Specifications:				
0				
0				
EQUIV CKT (OHMS / PHASE)				
R1	R2	X1	X2	Xm
0.5710	0.4910	2.2380	2.5130	43.1680

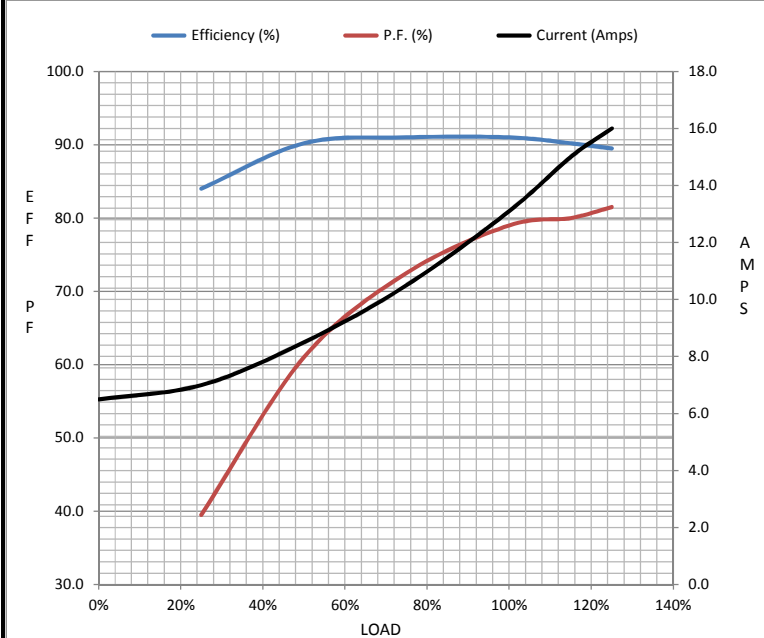

Speed -Torque Curve

