

PRODUCT INFORMATION PACKET

Model No: 254TTFL16077

Catalog No: E2142

7.50 HP General Purpose Motor, 3 phase, 1200 RPM, 575 V, 254T Frame, TEFC
General Purpose Motors





Nameplate Specifications

Output HP	7.50 Hp	Output KW	5.6 kW
Frequency	60 Hz	Voltage	575 V
Current	7.9 A	Speed	1175 rpm
Service Factor	1.15	Phase	3
Efficiency	91 %	Power Factor	78
Duty	Continuous	Insulation Class	F
Design Code	B	KVA Code	H
Frame	254T	Enclosure	Totally Enclosed Fan Cooled
Thermal Protection	No	Ambient Temperature	40 °C
Drive End Bearing Size	6309	Opp Drive End Bearing Size	6208
UL	Recognized	CSA	Y
CE	Y	IP Code	43
Number of Speeds	1		

Technical Specifications

Electrical Type	Squirrel Cage Inverter Rated	Starting Method	Line Or Inverter
Poles	6	Rotation	Reversible
Resistance Main	1.319 Ohms	Mounting	Rigid Base
Motor Orientation	Horizontal	Drive End Bearing	Ball
Opp Drive End Bearing	Ball	Frame Material	Aluminum
Shaft Type	T	Overall Length	23.51 in
Frame Length	12.00 in	Shaft Diameter	1.625 in
Shaft Extension	4.37 in	Assembly/Box Mounting	F1/F2 Capable
Connection Drawing	A-EE7300	Outline Drawing	B-SS321100-1200

This is an uncontrolled document once printed or downloaded and is subject to change without notice. Date Created:10/12/2021

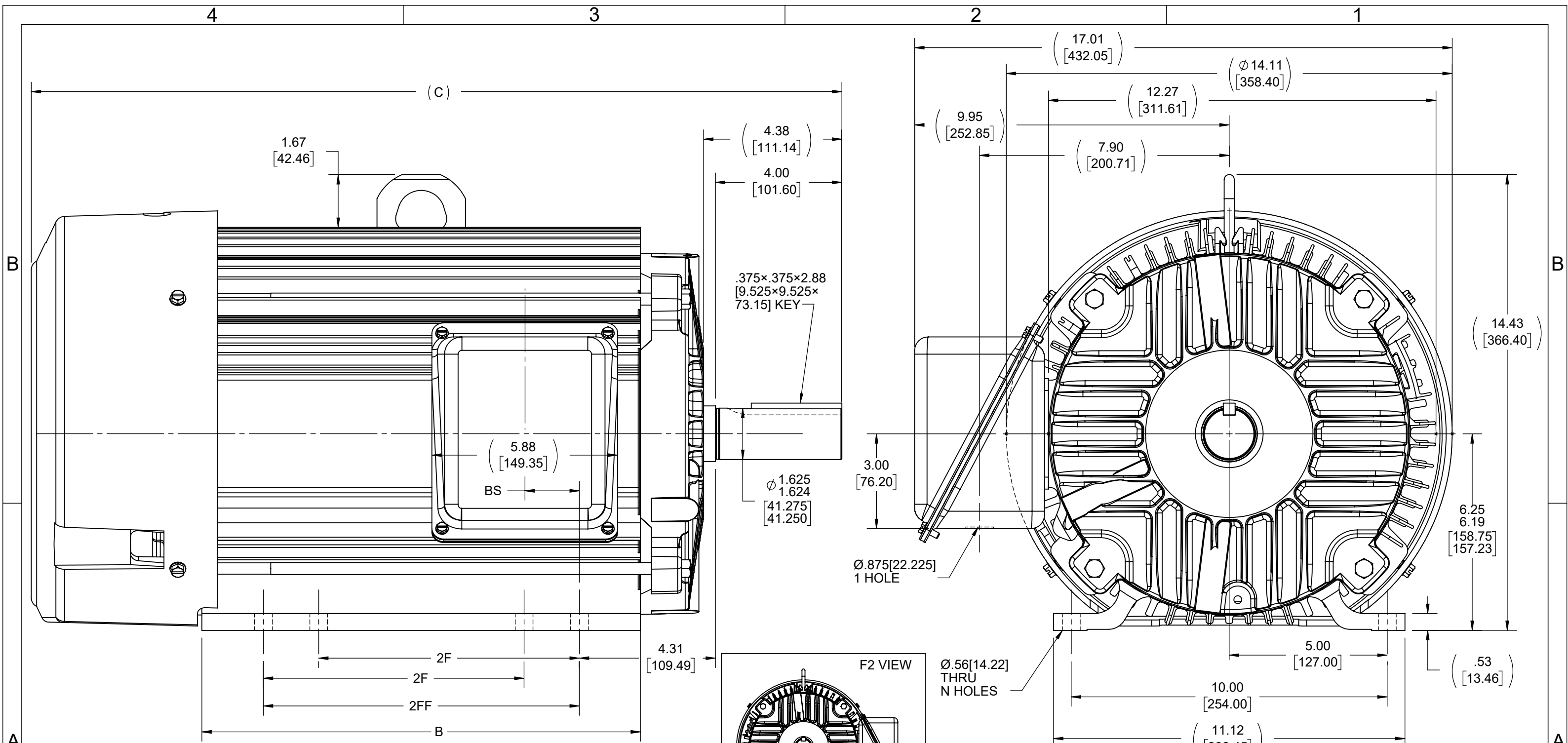

- NOTES:
1. CONDUIT BOX CAN BE ROTATED IN 90° STEPS.
 2. NAMEPLATES TO BE READ FROM CONDUIT BOX SIDE OF MOTOR.

DASH	FRAME	C	B	2F	2FF	BS	N
1200	254T	23.78 [603.90]	12.13 [308.10]	8.25 [209.55]	-----	1.73 [43.94]	4
1375	254/6T	25.66 [651.65]	13.88 [352.55]	8.25 [209.55]	10.00 [254.00]	1.73 [43.94]	8

DRAWING REVISION	REVISION BY	DATE
D	SP	05-26-2021
ECO	APPROVED BY	DATE
CR-0001205	AS	05-26-2021

ECO DESCRIPTION
REPLACED FAN GUARD 3C223-E3 TO 205016B
COPYRIGHT REGAL BELOIT AMERICA, INC. ALL RIGHTS RESERVED. PROPRIETARY AND CONFIDENTIAL INFORMATION - THIS DOCUMENT IS THE PROPERTY OF REGAL BELOIT AMERICA, INC. ("OWNER") AND CONTAINS OWNER'S PROPRIETARY INFORMATION. ANY PERSON, CORPORATION OR OTHER FIRM RECEIVING IT IS DEEMED, BY RECEIVING IT, TO AGREE THAT IT, AND/OR ANY PART OF IT, SHALL NOT BE DISCLOSED TO ANY PERSON, CORPORATION OR OTHER ENTITY, DUPLICATED, AND/OR USED, EXCEPT AS EXPRESSLY APPROVED IN WRITING IN ADVANCE BY OWNER. THIS DOCUMENT SHALL BE RETURNED TO OWNER UPON REQUEST. IT MAY BE SUBJECT TO CERTAIN RESTRICTIONS UNDER APPLICABLE EXPORT CONTROL LAWS AND REGULATIONS.

TOLERANCES UNLESS OTHERWISE SPECIFIED:

DEC.	INCH	mm	ANGLE
.X	±0.1	[±2.5]	±7° 30"
.XX	±0.03	[±0.76]	
.XXX	±0.005	[±0.127]	
.XXXX	±0.0005	[±0.0127]	

REMOVE BURRS & BREAK SHARP EDGES: .003/.015 [0.076/.381] X 45°
 CORNER FILLETS: R.02 [51]
 MACHINED SURFACES: 200 INCH 5.1 mm
 mm SHOWN IN [BRACKETS]

DRAWN BY	DATE
RJW	02-01-2005
APPROVED BY	DATE
BW	02-01-2005
REFERENCE	
THIRD ANGLE PROJECTION	

REGAL™ Regal Beloit America, Inc.	
DESCRIPTION	PROCESS/FINISH
OUTLINE 250T FR.-ALUM. FR.-TEFC	
SIZE	DRAWING NUMBER
B	SS321100
SHEET	1 OF 1

**THREE PHASE - SINGLE VOLTAGE
MOTOR - CONDUIT BOX @ 'A'**

**TO REVERSE ROTATION:
INTERCHANGE ANY TWO
LINE LEAD CONNECTIONS.**

TERMINAL BLOCK WHEN SPECIFIED



VIEW OF TERMINAL END

**IF MOTOR HAS
6 LEADS**



A-9806 DECAL

**OPTIONAL CORD
CONNECTION**



DRAWING REVISION AB	REVISION BY JJB	DATE 06-27-2017
ECO ECO-0125361	APPROVED BY TB	DATE 06-27-2017
ECO DESCRIPTION UPDATED TO CURRENT STANDARDS		
<small>COPYRIGHT REGAL BELOIT AMERICA, INC. ALL RIGHTS RESERVED. PROPRIETARY AND CONFIDENTIAL INFORMATION - THIS DOCUMENT IS THE PROPERTY OF REGAL BELOIT AMERICA, INC. ("OWNER") AND CONTAINS OWNER'S PROPRIETARY INFORMATION. ANY PERSON, CORPORATION OR OTHER FIRM RECEIVING IT IS DEEMED, BY RECEIVING IT, TO AGREE THAT IT, AND/OR ANY PART OF IT, SHALL NOT BE DISCLOSED TO ANY PERSON, CORPORATION OR OTHER ENTITY, DUPLICATED, AND/OR USED, EXCEPT AS EXPRESSLY APPROVED IN WRITING IN ADVANCE BY OWNER. THIS DOCUMENT SHALL BE RETURNED TO OWNER UPON REQUEST. IT MAY BE SUBJECT TO CERTAIN RESTRICTIONS UNDER APPLICABLE EXPORT CONTROL LAWS AND REGULATIONS.</small>		



DRAWN BY DA
DATE 03-26-1993
APPROVED BY TB
DATE 03-26-1993
REFERENCE
THIRD ANGLE PROJECTION

Regal Beloit America, Inc.		
		DESCRIPTION CONNECTION DIAGRAM EXTERNAL - SINGLE VOLTAGE - 3Ø MOTOR
MATERIAL	PROCESS/FINISH	
SIZE A	DRAWING NUMBER EE7300	SHEET 1 OF 1

CERTIFICATION DATA SHEET

Model#: 254TTFL16077 AN
CONN. DIAGRAM: A-EE7300
OUTLINE: B-SS321100-1200

WINDING#: 254653 R14 5
ASSEMBLY: F1/F2 CAPABLE

TYPICAL MOTOR PERFORMANCE DATA

HP	KW	SYNC. RPM	F.L. RPM	FRAME	ENCLOSURE	KVA CODE	DESIGN
7 1/2	5.60	1200	1175	254T	TEFC	H	B

PH	Hz	VOLTS	FL AMPS	START TYPE	DUTY	INSL	S.F	AMB°C	ELEVATION
3	60	575	7.9	LINE OR INVERTER	CONTINUOUS	F3	1.15	40	3300

FULL LOAD EFF: 91	3/4 LOAD EFF: 91	1/2 LOAD EFF: 90.2	GTD. EFF	ELEC. TYPE	NO LOAD AMPS
FULL LOAD PF: 78	3/4 LOAD PF: 72.5	1/2 LOAD PF: 61	90.2	SQ CAGE INV RATED	3.8

F.L. TORQUE	LOCKED ROTOR AMPS	L.R. TORQUE	B.D. TORQUE	F.L. RISE°C
33.5 LB-FT	50.8	72 LB-FT 215	103 LB-FT 307	40

SOUND PRESSURE @ 3 FT.	SOUND POWER	ROTOR WK^2	MAX. WK^2	SAFE STALL TIME	STARTS /HOUR	APPROX. MOTOR WGT
56 dBA	66 dBA	2.5 LB-FT^2	170 LB-FT^2	20 SEC.	2	350 LBS.

***** SUPPLEMENTAL INFORMATION *****

DE BRACKET TYPE	ODE BRACKET TYPE	MOUNT TYPE	ORIENTATION	SEVERE DUTY	HAZARDOUS LOCATION	DRIP COVER	SCREENS	PAINT
STANDARD	STANDARD	RIGID	HORIZONTAL	FALSE	NONE	FALSE	NONE	BLUE (ENAMEL)

BEARINGS		GREASE	SHAFT TYPE	SPECIAL DE	SPECIAL ODE	SHAFT MATERIAL	FRAME MATERIAL
DE	OPE						
BALL	BALL	POLYREX EM	T	NONE	NONE	1045 HOT ROLLED (C-204)	ALUMINUM
6309	6208						

THERMO-PROTECTORS				THERMISTORS	CONTROL	SPACE /n HEATERS
THERMOSTATS	PROTECTORS	WDG RTDs	BRG RTDs			
NONE	NOT	NONE	NONE	NONE	FALSE	NONE VOLTS

If Inverter equals NONE, contact factory for further information

*
N
O
T
E
S
*

INVERTER TORQUE: CONSTANT 10:1
INV. HP SPEED RANGE: NONE
ENCODER: NONE
NONE NONE
NONE NONE PPR
BRAKE: NONE NONE
NONE P/N NONE
NONE NONE
NONE FT-LB NONE V NONE Hz

DATE: 06/23/2017 04:16:33 AM
 FORM 3531 REV.3 02/07/99
 ** Subject to change without notice.

Data Sheet

Date: 19-06-2017
Customer: _____
Attention: _____
Submitted by: FAREEDA DUDEKULA



254TFL16077

Submittal

Data @ 575 V

Motor Load Data

Load	0%	25%	50%	75%	100%	115%	125%	LR
Current (Amps)	3.8	4.2	5.2	6.4	7.9	8.8	9.6	50.8
Torque (ft-lb)	0.00	8.0	16.5	25.0	33.5	38.5	42.0	72.0
RPM	1200	1195	1190	1180	1175	1,170	1165	0
Efficiency (%)		85.5	90.2	91.0	91.0	90.2	90.2	
P.F. (%)	7.0	40.0	61.0	72.5	78.0	80.0	80.5	42.0

Motor Speed Data

	LR	Pull-Up	BD	Rated	Idle
Speed (RPM)	0	600	1065	1175	1200
Current (Amps)	50.8	47.2	31.6	7.9	3.8
Torque (ft-lb)	72.0	69.0	103	33.5	0.00

Information Block				
HP	7.5			
Sync. RPM	1200			
Frame	254			
Enclosure	TEFC			
Construction	TFY			
Voltage	575 V			
Frequency	60 Hz			
Design	B			
LR Code letter	H			
Service Factor	1.15			
Temp Rise @ FL	40 ° C			
Duty	CONT			
Ambient	40 ° C			
Elevation	1,000 feet			
Rotor/Shaft wk ²	2.50 Lb-Ft ²			
Ref Wdg	254653 R14			
Sound Pressure @ 1M	56 dBA			
VFD Rating	CONSTANT 10:1			
Outline Dwg	B-SS321100-1200			
Conn. Diag	A-EE7300			
Additional Specifications:				
0				
365THFS8036				
EQUIV CKT (OHMS / PHASE)				
R1	R2	X1	X2	Xm
1.1520	1.0510	4.5360	4.9260	83.5730

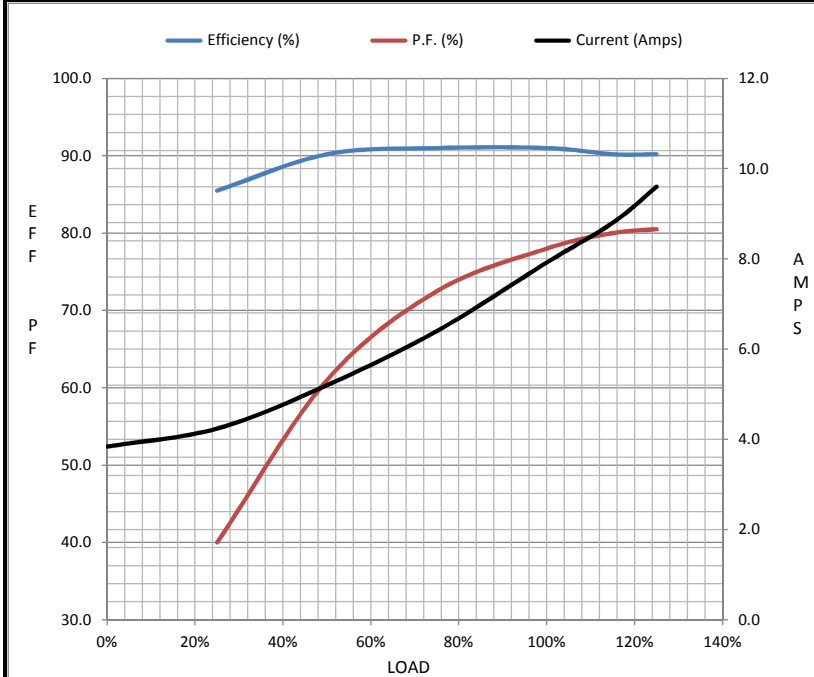

Speed - Torque Curve

