

# PRODUCT INFORMATION PACKET

Model No: 215TTWW14008

Catalog No: N664

PowerWash™ XT Wash Down Duty™ General Purpose Motor, 15 & 10 HP, 3 Ph, 60 & 50 Hz,  
230/460 & 190/380 V, 3600 & 3000 RPM, 215TC Frame, TEFC



Regal and Marathon are trademarks of Regal Rexnord Corporation or one of its affiliated companies.

©2023 Regal Rexnord Corporation, All Rights Reserved. MC017097E



### Nameplate Specifications

Phase	<b>3</b>	Output HP	<b>15 &amp; 10 Hp</b>
Output KW	<b>11.2 &amp; 7.5 kW</b>	Voltage	<b>230/460 &amp; 190/380 V</b>
Speed	<b>3520 &amp; 2940 rpm</b>	Service Factor	<b>1.15 &amp; 1.15</b>
Frame	<b>215TC</b>	Enclosure	<b>Totally Enclosed Fan Cooled</b>
Thermal Protection	<b>No Protection</b>	Efficiency	<b>90.2 &amp; 89.5 %</b>
Ambient Temperature	<b>40 °C</b>	Frequency	<b>60 &amp; 50 Hz</b>
Current	<b>36/18 &amp; 30/15 A</b>	Power Factor	<b>87</b>
Duty	<b>Continuous</b>	Insulation Class	<b>F</b>
Design Code	<b>B</b>	KVA Code	<b>G</b>
Drive End Bearing Size	<b>6309</b>	Opp Drive End Bearing Size	<b>6206</b>
UL	<b>Recognized</b>	CSA	<b>Y</b>
CE	<b>Y</b>	IP Code	<b>55</b>
Number of Speeds	<b>1</b>		

### Technical Specifications

Electrical Type	<b>Squirrel Cage Inverter Rated</b>	Starting Method	<b>Line Or Inverter</b>
Poles	<b>2</b>	Rotation	<b>Reversible</b>
Resistance Main	<b>.6 Ohms</b>	Mounting	<b>Round</b>
Motor Orientation	<b>Horizontal</b>	Drive End Bearing	<b>Ball</b>
Opp Drive End Bearing	<b>Ball</b>	Frame Material	<b>Rolled Steel</b>
Shaft Type	<b>T</b>	Overall Length	<b>20.58 in</b>
Frame Length	<b>11.15 in</b>	Shaft Diameter	<b>1.375 in</b>
Shaft Extension	<b>3.38 in</b>	Assembly/Box Mounting	<b>F1/F2 Capable</b>
Inverter Load	<b>VARIABLE 10:1</b>		
Outline Drawing	<b>A-SS88922-1115</b>	Connection Drawing	<b>A-EE7308</b>



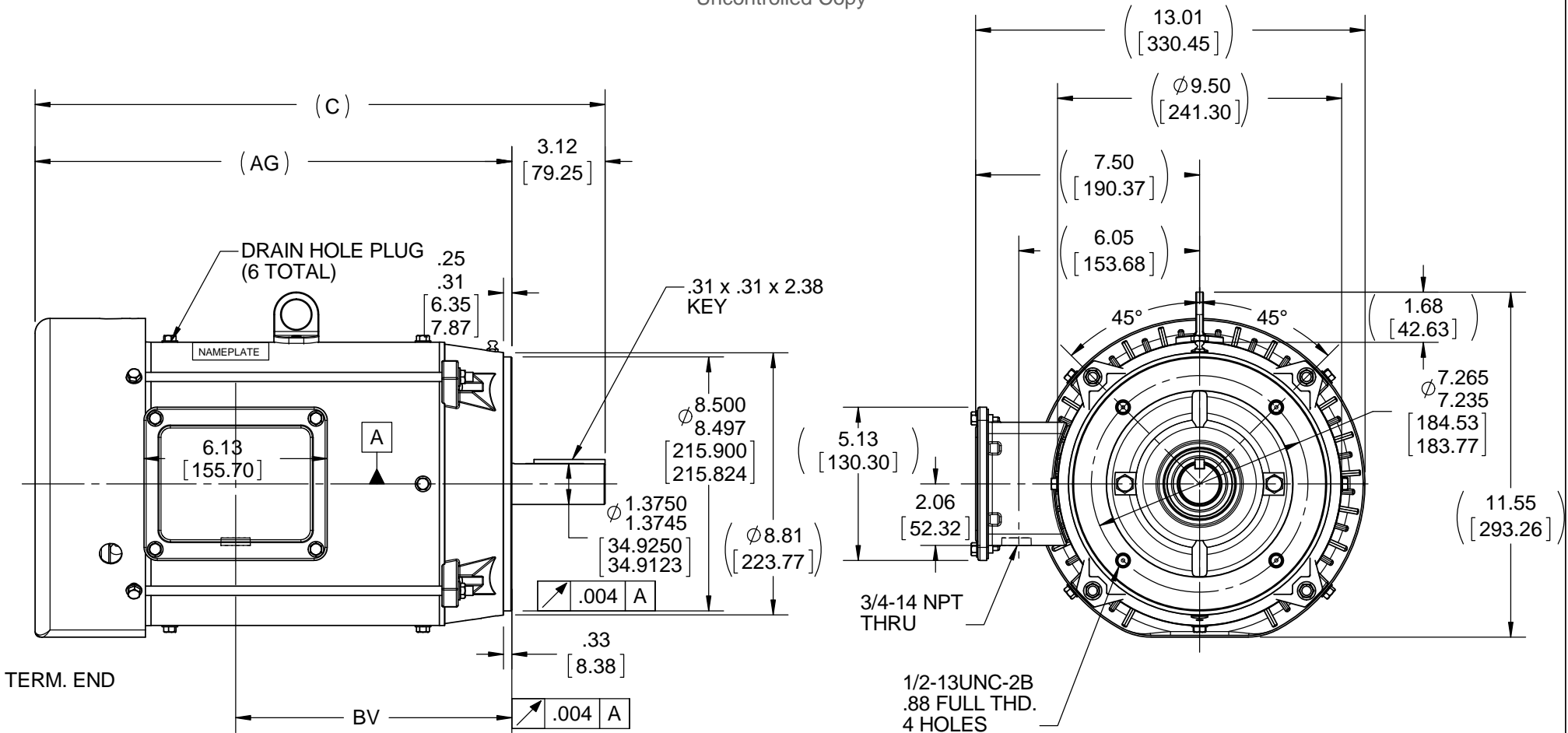

DASH	FRAME	C	AG	BV	MOUNTING
965	213T	19.08	15.96	9.26	
1115	213/15T	20.58	17.46	10.76	
1240	213/15T	21.83	18.71	12.01	F1 ONLY

NOTES:

- 1- NAMEPLATE TO BE READ FROM C'BOX SIDE OF MOTOR.
- 2- C'BOX CAN BE MOUNTED ON OPPOSITE SIDE BY REMOVING BRACKETS AND TURNING FRAME 180° (EXCEPT AS NOTED).
- 3- DASH 965 TO BE READ FROM OPPOSITE SHAFT END.

DRAWING REVISION <b>C</b>	REVISION BY <b>M. VERBICK</b>	DATE <b>6/2/2015</b>
ECO <b>ECO-0078542</b>	APPROVED BY	DATE
ECO DESCRIPTION <b>UPDATED TITLE BLOCK LOGO</b>		
<small>COPYRIGHT REGAL BELOIT AMERICA, INC. ALL RIGHTS RESERVED.                  PROPRIETARY AND CONFIDENTIAL INFORMATION - THIS DOCUMENT IS THE PROPERTY OF                  REGAL BELOIT AMERICA, INC. ('OWNER') AND CONTAINS OWNER'S PROPRIETARY                  INFORMATION. ANY PERSON, CORPORATION OR OTHER FIRM RECEIVING IT IS DEEMED,                  BY RECEIVING IT, TO AGREE THAT IT, AND/OR ANY PART OF IT, SHALL NOT BE DISCLOSED                  TO ANY PERSON, CORPORATION OR OTHER ENTITY, DUPLICATED, AND/OR USED, EXCEPT                  AS EXPRESSLY APPROVED IN WRITING IN ADVANCE BY OWNER. THIS DOCUMENT SHALL                  BE RETURNED TO OWNER UPON REQUEST. IT MAY BE SUBJECT TO CERTAIN                  RESTRICTIONS UNDER APPLICABLE EXPORT CONTROL LAWS AND REGULATIONS.</small>		

TOLERANCES UNLESS OTHERWISE SPECIFIED:			
DEC.	INCH	mm	ANGLE
.X	±0.1	[±2.5]	±7' 30"
.XX	±0.03	[±0.76]	
.XXX	±0.005	[±0.127]	
.XXXX	±0.0005	[±0.0127]	
REMOVE BURRS & BREAK SHARP EDGES: .003/.015 [.076/.381] X 45° CORNER FILLETS: R.02 [.51]			
MACHINED SURFACES: 200 INCH 5.1 mm			
mm SHOWN IN [BRACKETS]			

DRAWN BY <b>SR</b>
DATE <b>05/04/2011</b>
APPROVED BY <b>AK</b>
DATE <b>05/04/2011</b>
REFERENCE <b>SS88922LE</b>
THIRD ANGLE PROJECTION

Regal Beloit America, Inc.	
DESCRIPTION <b>OUTLINE</b>	
210 FR. - BB - TS - TEFC - R/S - C'FACE	
MATERIAL	PROCESS/FINISH
SIZE <b>A</b>	DRAWING NUMBER <b>SS88922</b>
SHEET <b>1 OF 1</b>	



NO.	REVISION	BY & DATE	CHK	ANG	TOLERANCES UNLESS SPECIFIED		FINISH	DRAWN RM 11/20/1990				
					DEC.	INCHES						
5	CHG TO REGAL LOGO	SL 09/10/2015	AB					CHK ML 11/21/1990				
4	REVISED IEC NOTATIONS	MSG 11/15/2011	CMN	.X	±.1			APPD SAS 04/24/2003				
3	ADDED IEC NOTATIONS... (U1), (V1) ETC. MU95194	MSG 5/10/2010	MJS	.XX	±.02		TITLE CONNECTION DIAGRAM	SCALE 1=1				
2	ADDED THE OPTIONAL CORD CONNECTION MU46318	RDH 04/24/2003	DRS	.XXX	±.005		3Ø - DUAL VOLTAGE MOTOR	REF				
1	REDRAWN	RM 11/20/1990		.XXXX	±.0005		MAT'L.	FMF				
					±7'30"			PREV				
THIS DRAWING IN DESIGN AND DETAIL IS OUR PROPERTY AND MUST NOT BE USED EXCEPT IN CONNECTION WITH OUR WORK ALL RIGHTS OF DESIGN AND INVENTION ARE RESERVED THIS IS AN ELECTRONICALLY GENERATED DOCUMENT - DO NOT SCALE THIS PRINT							RFP	CAD FILE ee7308	SIZE A	DRAWING NO. EE7308	PAGE OF 5	REV. 5
							DIST WP					