

# PRODUCT INFORMATION PACKET

Model No: 215TTWW14007

Catalog No: N214

PowerWash™ XT Wash Down Duty™ General Purpose Motor, 15 & 10 HP, 3 Ph, 60 & 50 Hz,  
230/460 & 190/380 V, 3600 & 3000 RPM, 215JM Frame, TEFC



Regal and Marathon are trademarks of Regal Rexnord Corporation or one of its affiliated companies.

©2023 Regal Rexnord Corporation, All Rights Reserved. MC017097E



### Nameplate Specifications

Phase	<b>3</b>	Output HP	<b>15 &amp; 10 Hp</b>
Output KW	<b>11.2 &amp; 7.5 kW</b>	Voltage	<b>230/460 &amp; 190/380 V</b>
Speed	<b>3520 &amp; 2940 rpm</b>	Service Factor	<b>1.15 &amp; 1.15</b>
Frame	<b>215JM</b>	Enclosure	<b>Totally Enclosed Fan Cooled</b>
Thermal Protection	<b>No Protection</b>	Efficiency	<b>90.2 &amp; 89.5 %</b>
Ambient Temperature	<b>40 °C</b>	Frequency	<b>60 &amp; 50 Hz</b>
Current	<b>36/18 &amp; 30/15 A</b>	Power Factor	<b>87</b>
Duty	<b>Continuous</b>	Insulation Class	<b>F</b>
Design Code	<b>B</b>	KVA Code	<b>G</b>
Drive End Bearing Size	<b>6309</b>	Opp Drive End Bearing Size	<b>6206</b>
UL	<b>Recognized</b>	CSA	<b>Y</b>
CE	<b>Y</b>	IP Code	<b>55</b>
Number of Speeds	<b>1</b>		

### Technical Specifications

Electrical Type	<b>Squirrel Cage Inverter Rated</b>	Starting Method	<b>Line Or Inverter</b>
Poles	<b>2</b>	Rotation	<b>Reversible</b>
Resistance Main	<b>.6 Ohms</b>	Mounting	<b>Rigid Base</b>
Motor Orientation	<b>Horizontal</b>	Drive End Bearing	<b>Ball</b>
Opp Drive End Bearing	<b>Ball</b>	Frame Material	<b>Rolled Steel</b>
Shaft Type	<b>JM</b>	Overall Length	<b>21.71 in</b>
Frame Length	<b>11.15 in</b>	Shaft Diameter	<b>1.000 in</b>
Shaft Extension	<b>4.28 in</b>	Assembly/Box Mounting	<b>F1/F2 Capable</b>
Inverter Load	<b>VARIABLE 10:1</b>		
Connection Drawing	<b>A-EE7308</b>	Outline Drawing	<b>SS88927-1115</b>



SS88927

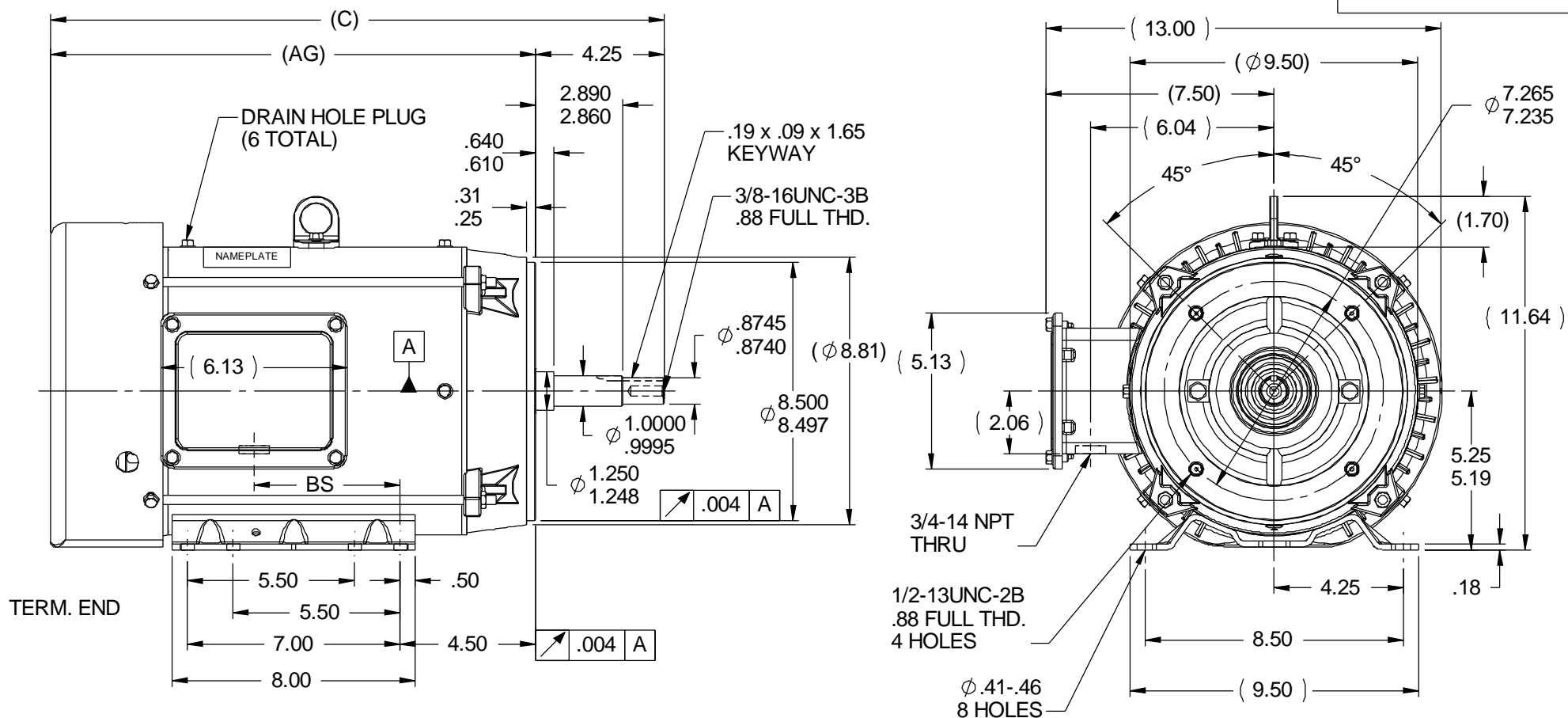

DASH	FRAME	C	BS	AG
965	213JM	20.21	4.81	15.96
1115	213/15JM	21.71	6.31	17.46
1240	215JM	22.96	7.56	18.71

NOTES:

- 1- NAMEPLATE TO BE READ FROM C'BOX SIDE OF MOTOR.
- 2- DASH 965 TO BE READ FROM OPPOSITE SHAFT END.
- 3- C'BOX CAN BE MOUNTED ON OPPOSITE SIDE BY REMOVING BRACKETS AND TURNING FRAME 180° (EXCEPT AS NOTED).

TOLERANCES UNLESS SPECIFIED		marathon <sup>®</sup> electric		DRAWN UD 08/21/13				
DEC	INCHES	TITLE OUTLINE - WASHDOWN 210FR. -TEFC - C'FACE - 3 PHASE		CHK SR 08/21/13				
.X	±.1			APPR				
.XX	±.03			SCALE 1:4				
.XXX	±.005			REF				
.XXXX	±.0005			FMF				
NO	REVISION	BY & DATE	CHK ANG ±1/2°	MAT'L	FINISH	PREV		
THIS DRAWING IN DESIGN AND DETAIL IS OUR PROPERTY AND MUST NOT BE USED EXCEPT IN CONNECTION WITH OUR WORK. ALL RIGHTS OF DESIGN AND INVENTION ARE RESERVED. THIS IS AN ELECTRONICALLY GENERATED DOCUMENT - DO NOT SCALE THIS PRINT				RFP	CAD FILE	SIZE	DRAWING NO	REV
				DIST	SS88927	A	SS88927	



NO.	REVISION	BY & DATE	CHK	ANG	TOLERANCES UNLESS SPECIFIED		FINISH	DRAWN RM 11/20/1990				
					DEC.	INCHES						
5	CHG TO REGAL LOGO	SL 09/10/2015	AB					CHK ML 11/21/1990				
4	REVISED IEC NOTATIONS	MSG 11/15/2011	CMN	.X	±.1			APPD SAS 04/24/2003				
3	ADDED IEC NOTATIONS... (U1), (V1) ETC. MU95194	MSG 5/10/2010	MJS	.XX	±.02		TITLE CONNECTION DIAGRAM	SCALE 1=1				
2	ADDED THE OPTIONAL CORD CONNECTION MU46318	RDH 04/24/2003	DRS	.XXX	±.005		3Ø - DUAL VOLTAGE MOTOR	REF				
1	REDRAWN	RM 11/20/1990		.XXXX	±.0005		MAT'L.	FMF				
					±7'30"			PREV				
THIS DRAWING IN DESIGN AND DETAIL IS OUR PROPERTY AND MUST NOT BE USED EXCEPT IN CONNECTION WITH OUR WORK ALL RIGHTS OF DESIGN AND INVENTION ARE RESERVED THIS IS AN ELECTRONICALLY GENERATED DOCUMENT - DO NOT SCALE THIS PRINT							RFP	CAD FILE ee7308	SIZE A	DRAWING NO. EE7308	PAGE OF 5	REV. 5
							DIST WP					