

# PRODUCT INFORMATION PACKET

marathon®  
Motors

Model No: 215TTWRD6026

Catalog No: N619B

PowerWash™ XT Wash Down Duty™ General Purpose Motor, 10 & 7.5 HP, 3 Ph, 60 & 50 Hz,  
208-230/460 & 190/380 V, 1800 & 1500 RPM, 215TC Frame, TEFC



Regal and Marathon are trademarks of Regal Rexnord Corporation or one of its affiliated companies.

©2023 Regal Rexnord Corporation, All Rights Reserved. MC017097E

RegalRexnord



### Nameplate Specifications

Phase	<b>3</b>	Output HP	<b>10 &amp; 7.50 Hp</b>
Output KW	<b>7.5 &amp; 5.6 kW</b>	Voltage	<b>208-230/460 &amp; 190/380 V</b>
Speed	<b>1760 &amp; rpm</b>	Service Factor	<b>1.15 &amp; 1.0</b>
Frame	<b>215TC</b>	Enclosure	<b>Totally Enclosed Fan Cooled</b>
Thermal Protection	<b>No Protection</b>	Efficiency	<b>91.7 %</b>
Ambient Temperature	<b>40 °C</b>	Frequency	<b>60 &amp; 50 Hz</b>
Current	<b>14-26.4/13.2 &amp; 27.4/13.7 A</b>	Power Factor	<b>77.5</b>
Duty	<b>Continuous</b>	Insulation Class	<b>F</b>
Design Code	<b>B</b>	KVA Code	<b>H</b>
Drive End Bearing Size	<b>6309</b>	Opp Drive End Bearing Size	<b>6206</b>
UL	<b>Recognized</b>	CSA	<b>Y</b>
CE	<b>Y</b>	IP Code	<b>43</b>
Number of Speeds	<b>1</b>		

### Technical Specifications

Electrical Type	<b>Squirrel Cage Inverter Rated</b>	Starting Method	<b>Line Or Inverter</b>
Poles	<b>4</b>	Rotation	<b>Reversible</b>
Resistance Main	<b>.9 Ohms</b>	Mounting	<b>Rigid Base</b>
Motor Orientation	<b>Horizontal</b>	Drive End Bearing	<b>Ball</b>
Opp Drive End Bearing	<b>Ball</b>	Frame Material	<b>Rolled Steel</b>
Shaft Type	<b>T</b>	Overall Length	<b>20.27 in</b>
Frame Length	<b>11.15 in</b>	Shaft Diameter	<b>1.375 in</b>
Shaft Extension	<b>3.12 in</b>	Assembly/Box Mounting	<b>F1/F2 CAPABLE</b>
Inverter Load	<b>CONSTANT 10:1</b>		
Connection Drawing	<b>005010.01</b>	Outline Drawing	<b>038033-1115</b>



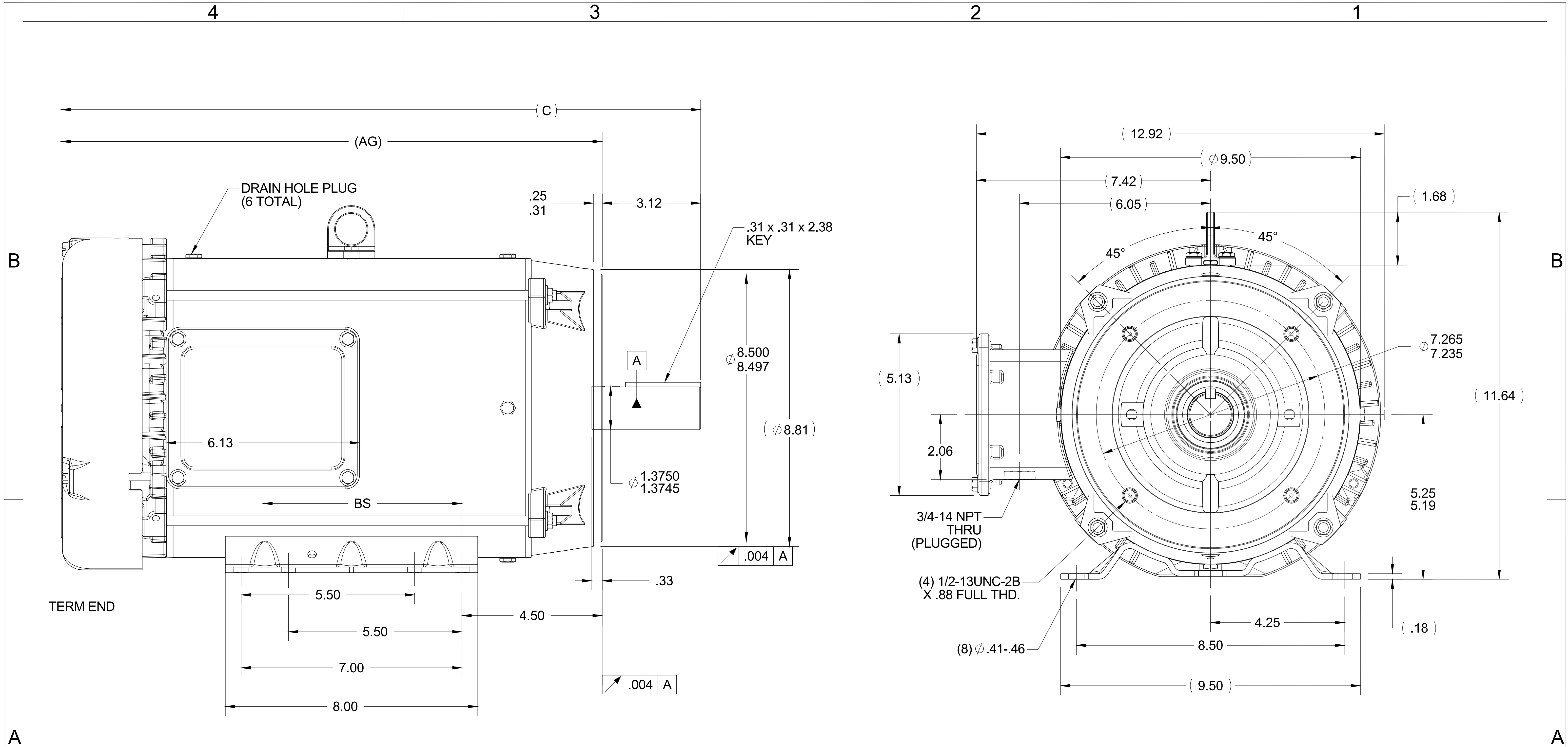

NOTES:  
 1- NAMEPLATE TO BE READ FROM C'BOX SIDE OF MOTOR.  
 DASH 965 TO BE READ FROM OPPOSITE SHAFT END  
 2- C'BOX CAN BE MOUNTED ON OPPOSITE SIDE BY REMOVING BRACKETS AND TURNING FRAME 180 DEGREES (EXCEPT AS NOTED).

ORACLE REV  
001

DRAWING REVISION B	REVISION BY SAJID	DATE 08/25/15
ECO ECO-0084019	APPROVED BY JD	DATE 08/25/15
ECO DESCRIPTION FAN GUARD UPDATED		
<small>COPYRIGHT REGAL BELOIT AMERICA, INC. ALL RIGHTS RESERVED. PROPRIETARY AND CONFIDENTIAL INFORMATION - THIS DOCUMENT IS THE PROPERTY OF REGAL BELOIT AMERICA, INC. ("OWNER") AND CONTAINS OWNER'S PROPRIETARY INFORMATION. ANY PERSON, CORPORATION OR OTHER FIRM RECEIVING IT IS DEEMED, BY RECEIVING IT, TO AGREE THAT IT, AND/OR ANY PART OF IT, SHALL NOT BE DISCLOSED TO ANY PERSON, CORPORATION OR OTHER ENTITY, DUPLICATED, AND/OR USED, EXCEPT AS EXPRESSLY APPROVED IN WRITING IN ADVANCE BY OWNER. THIS DOCUMENT SHALL BE RETURNED TO OWNER UPON REQUEST. IT MAY BE SUBJECT TO CERTAIN RESTRICTIONS UNDER APPLICABLE EXPORT CONTROL LAWS AND REGULATIONS.</small>		

TOLERANCES UNLESS OTHERWISE SPECIFIED:

DEC.	INCH	mm	ANGLE
.X	±0.1	[±2.5]	±0.5°
.XX	±0.03	[±0.76]	
.XXX	±0.005	[±0.127]	
.XXXX	±0.0005	[±0.0127]	

REMOVE BURRS & BREAK SHARP EDGES: .003/.015 [0.076/.381] X 45°  
 CORNER FILLETS: R.02 [.51]  
 MACHINED SURFACES: 125 INCH 3.2 mm mm SHOWN IN [BRACKETS]

DRAWN BY SS	DATE 08/20/15
APPROVED BY JD	DATE 08/20/15
REFERENCE	THIRD ANGLE PROJECTION

<b>REGAL</b> ™ Regal Beloit America, Inc.	
DESCRIPTION <b>OUTLINE</b>	
WASHDOWN 210FR-TEFC-C-FACE-3PH	
MATERIAL	PROCESS/FINISH
SIZE <b>B</b>	DRAWING NUMBER <b>038033</b>
	SHEET 1 OF 1

DASH	FRAME	C	BS	AG	MOUNTING
965	213T	18.77	4.82	15.65	
1115	213/15T	20.27	6.32	17.15	
1240	215T	21.52	7.57	18.40	F1 ONLY

005010-01

VIEW FROM OUTSIDE OF MOTOR AT SWITCH END.

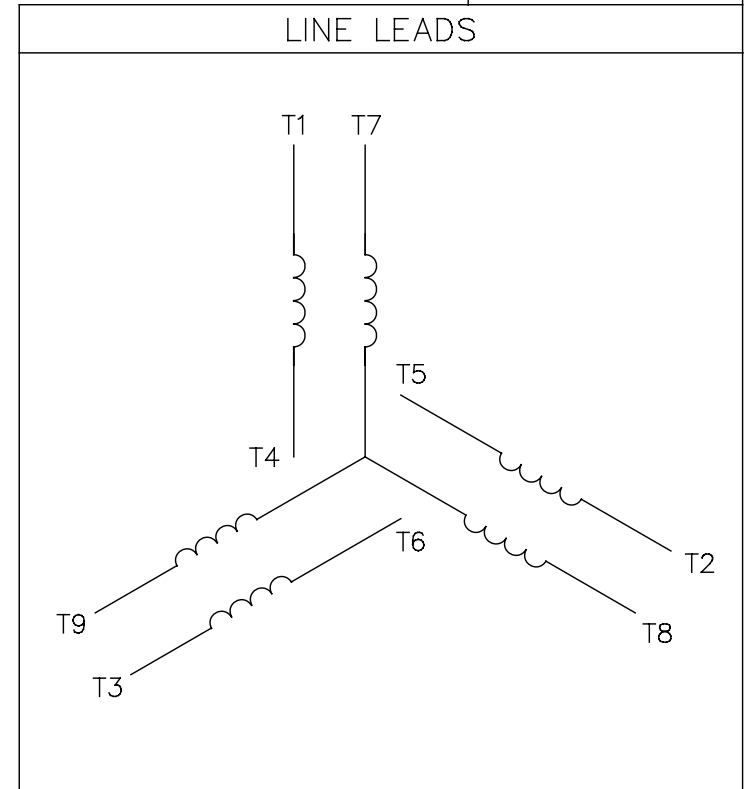

VOLTAGE	L1	L2	L3	JOIN & INSULATE
HIGH	T1	T2	T3	(T4,T7) (T5,T8) (T6,T9)
LOW	T1,T7	T2,T8	T3,T9	T4,T5,T6

				TOLERANCES UNLESS SPECIFIED		<b>REGAL</b> ™ <b>Regal Beloit America, Inc.</b>		DRAWN RDW 04/12/02				
				DEC.	INCHES			CHK				
				.X	±.1			APPD				
				.XX	±.01	TITLE EXTERNAL WIRING DIAGRAM 3 PHASE W/O PROTECTOR		SCALE 1=1				
				.XXX	±.005			REF FIG.2-51				
A	UPDATED TO REGAL LOGO			SAJ	06/26/15	AJY	.XXXX	±.0005	MAT'L. DECAL - 004014	FMF		
NO.	REVISION			BY & DATE	CHK	ANG	±1/2"	FINISH	PREV			
THIS DRAWING IN DESIGN AND DETAIL IS OUR PROPERTY AND MUST NOT BE USED EXCEPT IN CONNECTION WITH OUR WORK ALL RIGHTS OF DESIGN AND INVENTION ARE RESERVED THIS IS AN ELECTRONICALLY GENERATED DOCUMENT - DO NOT SCALE THIS PRINT				RFP	04/12/02		CAD FILE	00501001		SIZE	DRAWING NO.	REV.
				DIST	BRF-NLV			A	005010-01		A	



P.O. BOX 8003  
WAUSAU, WI 54401-8003  
PH. 715-675-3311

DATA VOLTS: 460

**CERTIFICATION DATA SHEET**

CUSTOMER: \_\_\_\_\_ CUSTOMER P.O. #: \_\_\_\_\_  
 ORDER #: \_\_\_\_\_ REFERENCE MODEL #: 215TTWRD6026  
 CONN. DIAGRAM: 005010.01 CAT #: N619A  
 OUTLINE: 038033-1115 CUSTOMER PART #: \_\_\_\_\_  
 WINDING: K2154513 NONE 3 MOUNTING: F1/F2 CAPABLE  
 SPEED: \_\_\_\_\_

**TYPICAL MOTOR PERFORMANCE DATA**

HP	KW	SYNC RPM	FL RPM	FRAME	ENCLOSURE	TYPE	KVA CODE	DESIGN	
10	7.5	1800	1760	215TC	TEFC	TFW	H	B	
PH	HZ	VOLTS	AMPS	START TYPE	DUTY	INSL	S.F.	AMB	ELEV.
3	60/50	208-230/460#190/380	14-26.4/13.2&27.4/13.7	LINE OR INVERTER	CONT	F	1.15	40	3300
F.L. EFF	91.7	3/4 LD EFF	91.7	1/2 LD EFF	91.0	GTD EFF	90.2	ELECT. TYPE	
F.L. PF	77.5	3/4 LD PF	69.6	1/2 LD PF	57.2	SQ CAGE INV RATED			
F.L. TORQUE	LR AMPS @ 460 V	L.R. TORQUE	B.D. TORQUE	F.L. RISE (°C)					
29.9 LB-FT	81.0	76.0 LB-FT 254%	90.0 LB-FT 301%	65					
@ 3 FT.	POWER	ROTOR WK <sup>2</sup>	MAX. LOAD WK <sup>2</sup>	SAFE STALL TIME	STARTS/HOUR	MOTOR WGT			
62 dBA	71 dBA	1.10 LB-FT <sup>2</sup>	50 LB-FT <sup>2</sup>	20 SEC.	2	150	LB.		
*** SUPPLEMENTAL INFORMATION ***									
DE BRACKET TYPE	ODE BRACKET TYPE	MOUNT TYPE	MOTOR ORIENTATION	SEVERE DUTY	HAZARDOUS LOCATION	DRIP COVER	SCREENS	PAINT	
C-FACE	STANDARD	RIGID	HORIZONTAL	NO	NONE	NO	NONE	HITE - LEESON (EPO)	
BEARINGS		GREASE	SHAFT TYPE	SPECIAL DE	SPECIAL ODE	SHAFT MATERIAL	FRAME MATERIAL		
DE	ODE	POLYREX EM	T	NONE	NONE	303 STAINLESS (C-501)	ROLLED STEEL		
BALL	BALL								
6309	6206								
THERMOSTATS	PROTECTORS	WDG RTD's	BRG RTD's	THERMISTORS	CONTROL	SPACE HEATERS			
NONE	NOT	NONE	NONE	NONE	FALSE	NA			
R1 (ohms/ph)	R2 (ohms/ph)	X1 (ohms/ph)	X2 (ohms/ph)	Xm (ohms/ph)	VIBRATION (in/sec)	FLOAT			
0.584	0.505	1.764	2.136	36.032	0.150	ODE			

* N O T E S *						INVERTER TORQUE: CONSTANT 10:1 INV. HP SPEED RANGE: NONE				
						ENCODER: NONE NONE NONE NONE PPR				
	PREPARED BY: FAREEDA DUDEKULA DATE: 11/5/2018					BRAKE: NONE NONE NONE FT-LB: NA VOLTAGE: NONE HZ:				
						UL: V-INS, CONST UL REC				

FORM: 3531 REV\_4 2/27/06

Data Sheet

213TTWRD6002

Date: 12/5/2018  
 Customer: \_\_\_\_\_  
 Attention: \_\_\_\_\_  
 Submitted by: FAREEDA DUDEKULA



Submittal

Data @ 460 V

Motor Load Data

Load	0%	25%	50%	75%	100%	115%	125%	LR
Current (Amps)	4.1	4.5	5.8	7.4	9.3	10.2	11.4	63.0
Torque (ft-lb)	0.00	2.70	5.5	8.3	11.2	12.5	14.0	19.3
RPM	3600	3585	3565	3545	3525	3,520	3505	0
Efficiency (%)		81.8	88.1	88.9	89.5	89.9	88.1	
P.F. (%)	8.0	46.9	68.4	79.7	84.6	85.5	87.1	0.0

Motor Speed Data

	LR	Pull-Up	BD	Rated	Idle
Speed (RPM)	0	552	3130	3525	3600
Current (Amps)	63.0	60.0	38.0	9.3	4.1
Torque (ft-lb)	19.3	19.0	33.0	11.2	0.00

Information Block

HP	7.5			
Sync. RPM	3600			
Frame	213			
Enclosure	TEFC			
Construction	TFR			
Voltage	208-230/460#190/380 V			
Frequency	60 Hz			
Design	B			
LR Code letter	H			
Service Factor	1.15			
Temp Rise @ FL	55 °C			
Duty	CONT			
Ambient	40 °C			
Elevation	1,000 feet			
Rotor/Shaft wk <sup>2</sup>	0.55 Lb-Ft <sup>2</sup>			
Ref Wdg	K2132124 NONE			
Sound Pressure @ 1M	72 dBA			
VFD Rating	CONSTANT 10:1			
Outline Dwg	038033			
Conn. Diag	005010.01			
Additional Specifications:				
0				
0				
EQUIV CKT (OHMS / PHASE)				
R1	R2	X1	X2	Xm
1.0550	0.5750	2.5440	1.4140	56.7000

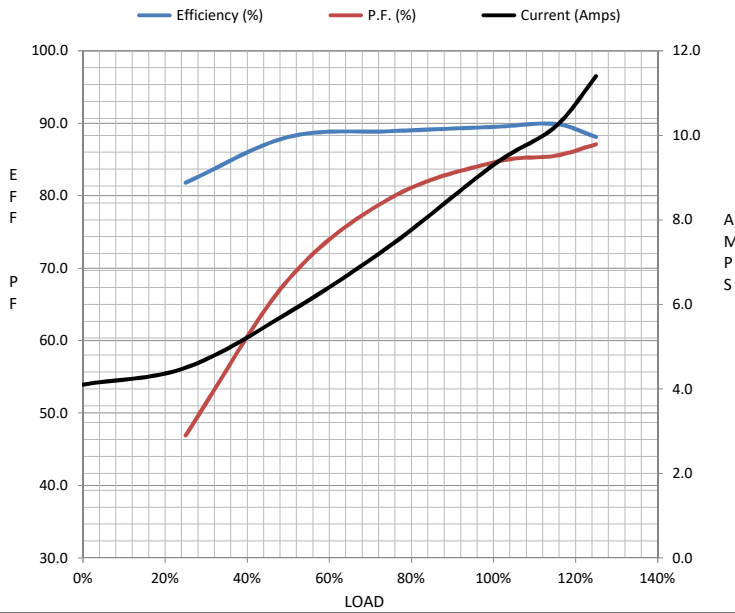

Speed - Torque Curve

