

PRODUCT INFORMATION PACKET

Model No: 215TTWD14032

Catalog No: N163

General Purpose Motor, 10 & 7.5 HP, 3 Ph, 60 & 50 Hz, 230/460 & 190/380 V, 1800 & 1500 RPM,
215JM Frame, TEFC



Regal and Marathon are trademarks of Regal Rexnord Corporation or one of its affiliated companies.

©2023 Regal Rexnord Corporation, All Rights Reserved. MC017097E

Nameplate Specifications

Phase	3	Output HP	10 & 7.50 Hp
Output KW	7.5 & 5.6 kW	Voltage	230/460 & 190/380 V
Speed	1760 & 1450 rpm	Service Factor	1.15 & 1.15
Frame	215JM	Enclosure	Totally Enclosed Fan Cooled
Thermal Protection	No Protection	Efficiency	89.5 & 90.2 %
Ambient Temperature	40 °C	Frequency	60 & 50 Hz
Current	28/14 & 26/13 A	Power Factor	76
Duty	Continuous	Insulation Class	F
Design Code	B	KVA Code	J
Drive End Bearing Size	6209	Opp Drive End Bearing Size	6207
UL	Recognized	CSA	Y
CE	Y	IP Code	56
Number of Speeds	1		

Technical Specifications

Electrical Type	Squirrel Cage Inverter Rated	Starting Method	Line Or Inverter
Poles	4	Rotation	Reversible
Resistance Main	.99 Ohms	Mounting	Rigid Base
Motor Orientation	Horizontal	Drive End Bearing	Ball
Opp Drive End Bearing	Ball	Frame Material	Stainless Steel
Shaft Type	JM	Overall Length	24.50 in
Shaft Diameter	1.375 in	Shaft Extension	4.28 in
Assembly/Box Mounting	F1 ONLY	Inverter Load	CONSTANT 3:1
Outline Drawing	037618ME	Connection Drawing	005010.01ME

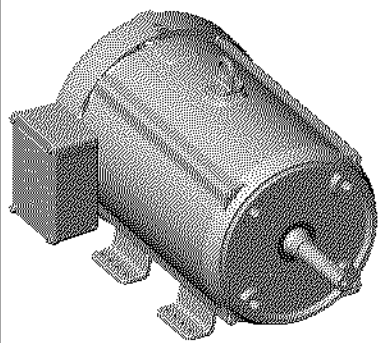
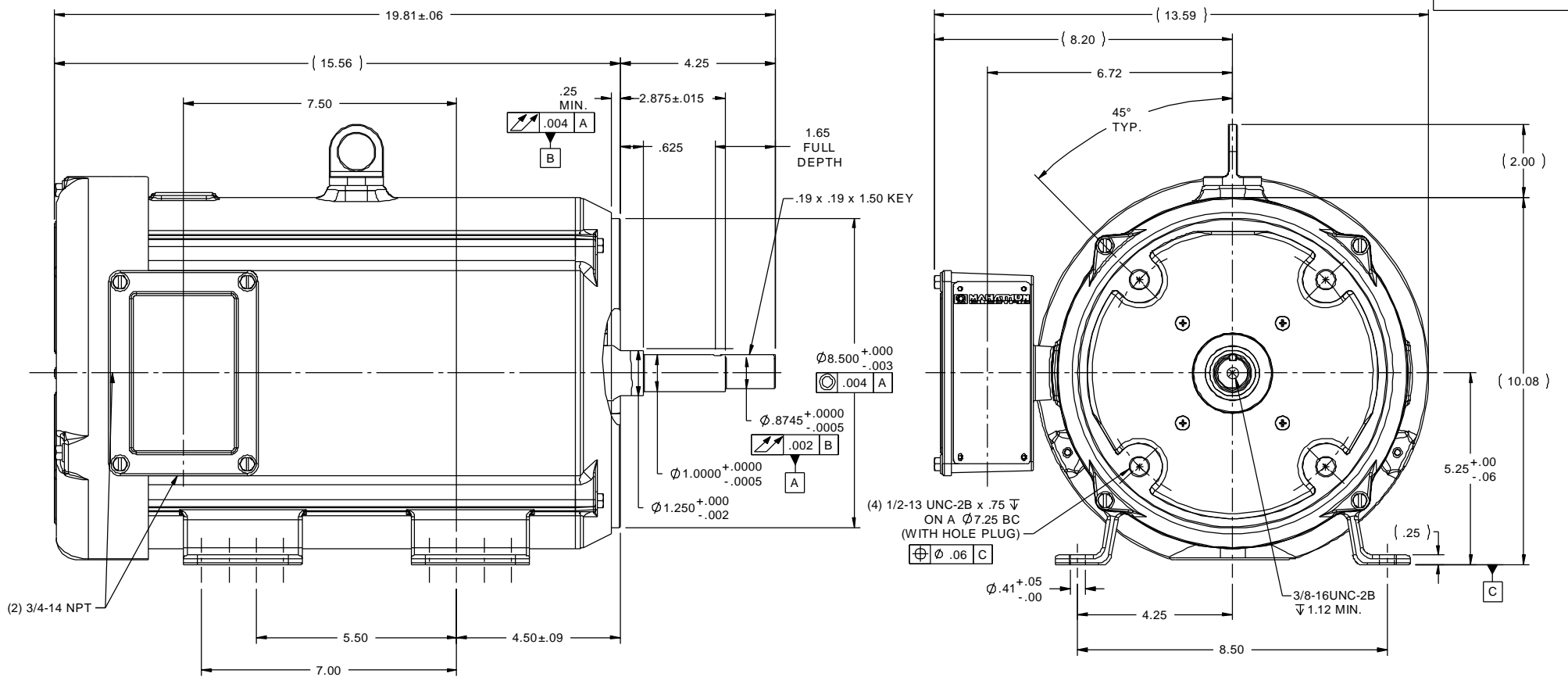

TOLERANCES UNLESS SPECIFIED		DEC INCHES		marathon electric		DRAWN PVR 10/24/13	
							CHK JD 10/24/13
		X	±.1				APPR
		XX	±.03				SCALE 3:8
		XXX	±.005				REF 037618
		XXXX	±.0005				FMF 213TTWD14002
NO	REVISION	BY & DATE	CHK	ANG ±1/2°	FINISH		PREV
THIS DRAWING IN DESIGN AND DETAIL IS OUR PROPERTY AND MUST NOT BE USED EXCEPT IN CONNECTION WITH OUR WORK. ALL RIGHTS OF DESIGN AND INVENTION ARE RESERVED.				RFP	CAD FILE	SIZE	DRAWING NO
THIS IS AN ELECTRONICALLY GENERATED DOCUMENT - DO NOT SCALE THIS PRINT				DIST	037618ME	B	037618ME
							REV

VIEW FROM OUTSIDE OF MOTOR AT SWITCH END.



VOLTAGE	L1	L2	L3	JOIN & INSULATE
HIGH	T1	T2	T3	(T4,T7) (T5,T8) (T6,T9)
LOW	T1,T7	T2,T8	T3,T9	T4,T5,T6

		TOLERANCES UNLESS SPECIFIED		DRAWN RDW 04/12/02					
		DEC.	INCHES	CHK					
		.X	±.1	APPD					
		.XX	±.01	SCALE 1=1					
		.XXX	±.005	REF FIG.2-51					
		.XXXX	±.0005	FMF					
NO.	REVISION	BY & DATE	CHK	ANG	FINISH	PREV			
				±1/2'					
THIS DRAWING IN DESIGN AND DETAIL IS OUR PROPERTY AND MUST NOT BE USED EXCEPT IN CONNECTION WITH OUR WORK ALL RIGHTS OF DESIGN AND INVENTION ARE RESERVED THIS IS AN ELECTRONICALLY GENERATED DOCUMENT - DO NOT SCALE THIS PRINT			RFP	04/12/02	CAD FILE	00501001ME	SIZE	DRAWING NO.	REV.
			DIST				A	005010-01ME	



TITLE EXTERNAL WIRING DIAGRAM
3 PHASE W/O PROTECTOR
MAT'L. DECAL - 004014