

PRODUCT INFORMATION PACKET

Model No: 215TTFND6807

Catalog No: E478A

10 HP Severe Duty Motor, 3 phase, 3600 RPM, 230/460 V, 215T Frame, TEFC
Severe Duty Motors



Regal and Marathon are trademarks of Regal Rexnord Corporation or one of its affiliated companies.
©2021 Regal Rexnord Corporation, All Rights Reserved. MC017097E



Nameplate Specifications

Output HP	10 Hp	Output KW	7.5 kW
Frequency	60 Hz	Voltage	230/460 V
Current	23.8/11.9 A	Speed	3520 rpm
Service Factor	1.15	Phase	3
Efficiency	90.2 %	Power Factor	87.1
Duty	Continuous	Insulation Class	F
Design Code	B	KVA Code	H
Frame	215T	Enclosure	Totally Enclosed Fan Cooled
Thermal Protection	No	Ambient Temperature	40 °C
Drive End Bearing Size	6307	Opp Drive End Bearing Size	6208
UL	Recognized	CSA	Y
CE	Y	IP Code	54
Number of Speeds	1		

Technical Specifications

Electrical Type	Squirrel Cage Inverter Rated	Starting Method	Line Or Inverter
Poles	2	Rotation	Reversible
Resistance Main	.8 Ohms	Mounting	Rigid Base
Motor Orientation	Horizontal	Drive End Bearing	Ball
Opp Drive End Bearing	Ball	Frame Material	Cast Iron
Shaft Type	T	Shaft Diameter	1.375 in
Assembly/Box Mounting	F1/F2 CAPABLE		
Connection Drawing	A-EE7308	Outline Drawing	037657-912

This is an uncontrolled document once printed or downloaded and is subject to change without notice. Date Created:10/11/2021

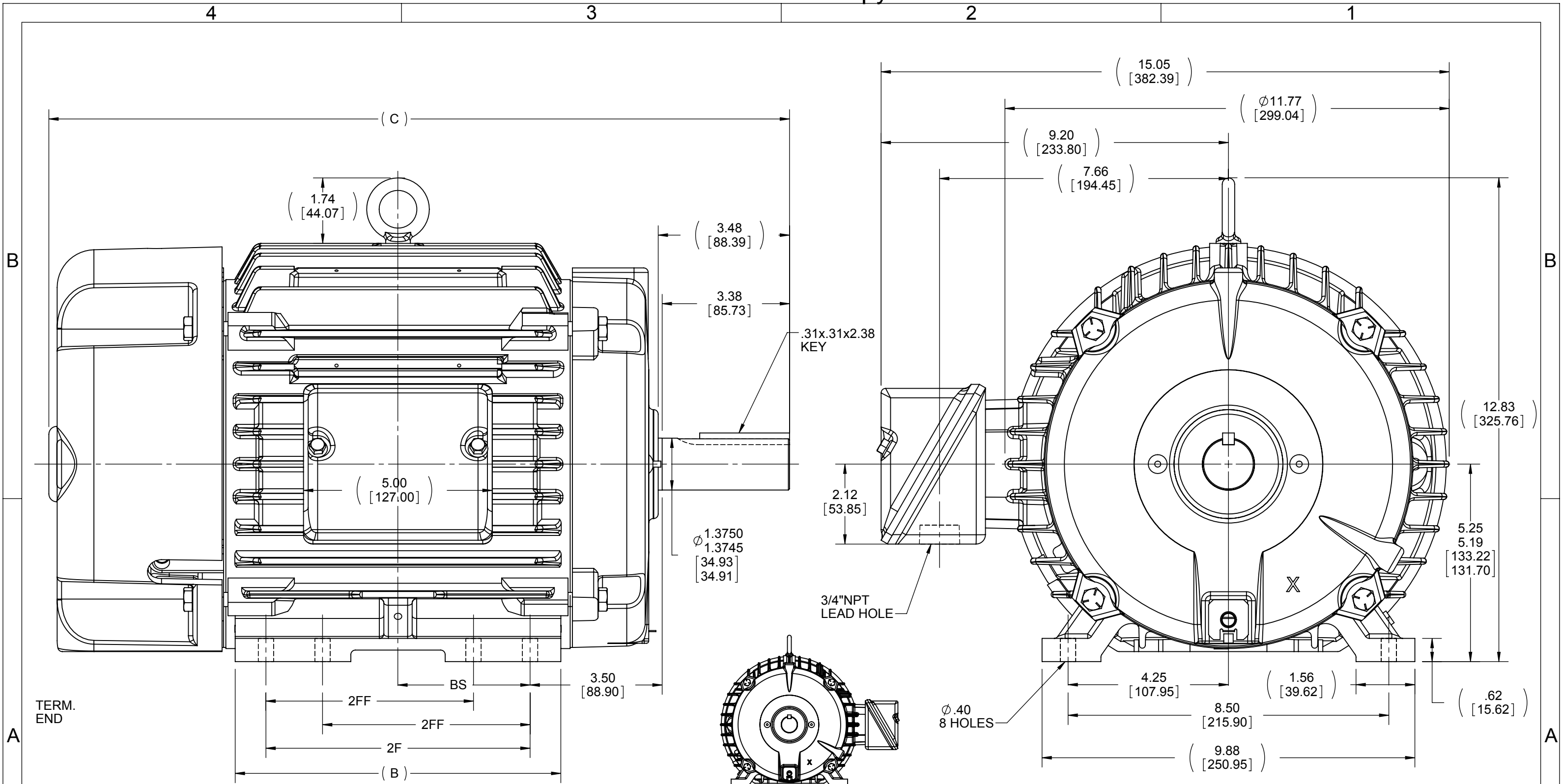

NOTES:

1. CONDUIT BOX CAN BE ROTATED IN 90° STEPS.
2. CONDUIT BOX CAN BE MOUNTED IN OPPOSITE SIDE BY REMOVING BRACKETS AND TURNING FRAME 180°.
3. NAMEPLATE TO BE READ FROM CONDUIT BOX SIDE OF MOTOR.

1212	213/215	22.63	11.76	10	7	5
912	213/215	19.63	8.63	7	5.5	3.5
DASH	FRAME	C	B	2F	2FF	BS

DRAWING REVISION E	REVISION BY UD	DATE 02/13/14
ECO ECO-0044824	APPROVED BY SR	DATE 02/13/14
ECO DESCRIPTION ADDED F2 VIEW		
<small>COPYRIGHT REGAL BELOIT AMERICA, INC. ALL RIGHTS RESERVED. PROPRIETARY AND CONFIDENTIAL INFORMATION - THIS DOCUMENT IS THE PROPERTY OF REGAL BELOIT AMERICA, INC. ("OWNER") AND CONTAINS OWNER'S PROPRIETARY INFORMATION. ANY PERSON, CORPORATION OR OTHER FIRM RECEIVING IT IS DEEMED, BY RECEIVING IT, TO AGREE THAT IT, AND/OR ANY PART OF IT, SHALL NOT BE DISCLOSED TO ANY PERSON, CORPORATION OR OTHER ENTITY, DUPLICATED, AND/OR USED, EXCEPT AS EXPRESSLY APPROVED IN WRITING IN ADVANCE BY OWNER. THIS DOCUMENT SHALL BE RETURNED TO OWNER UPON REQUEST. IT MAY BE SUBJECT TO CERTAIN RESTRICTIONS UNDER APPLICABLE EXPORT CONTROL LAWS AND REGULATIONS.</small>		

TOLERANCES UNLESS OTHERWISE SPECIFIED:

DEC.	INCH	mm	ANGLE
.X	±0.1	[±2.5]	±0.5°
.XX	±0.01	[±0.25]	
.XXX	±0.005	[±0.127]	
.XXXX	±0.0005	[±0.0127]	

REMOVE BURRS & BREAK SHARP
 EDGES: .003/.015 [0.076/.381]
 CORNER FILLETS: .02 [0.51]
 MACHINED SURFACES: 125 INCH 3.2 mm
 mm SHOWN IN [BRACKETS]

DRAWN BY AK	DATE 09/09/2009
APPROVED BY	DATE
PROCESS/FINISH	THIRD ANGLE PROJECTION

Regal Beloit America, Inc.	
DESCRIPTION OUTLINE	
SIZE B	DRAWING NUMBER 037657
SHEET 1 OF 1	



NO.	REVISION	BY & DATE	CHK	ANG	TOLERANCES UNLESS SPECIFIED		FINISH	DRAWN RM 11/20/1990				
					DEC.	INCHES						
5	CHG TO REGAL LOGO	SL 09/10/2015	AB					CHK ML 11/21/1990				
4	REVISED IEC NOTATIONS	MSG 11/15/2011	CMN	.X	±.1			APPD SAS 04/24/2003				
3	ADDED IEC NOTATIONS... (U1), (V1) ETC. MU95194	MSG 5/10/2010	MJS	.XX	±.02		TITLE CONNECTION DIAGRAM	SCALE 1=1				
2	ADDED THE OPTIONAL CORD CONNECTION MU46318	RDH 04/24/2003	DRS	.XXX	±.005		3Ø - DUAL VOLTAGE MOTOR	REF				
1	REDRAWN	RM 11/20/1990		.XXXX	±.0005		MAT'L.	FMF				
					±7'30"			PREV				
THIS DRAWING IN DESIGN AND DETAIL IS OUR PROPERTY AND MUST NOT BE USED EXCEPT IN CONNECTION WITH OUR WORK ALL RIGHTS OF DESIGN AND INVENTION ARE RESERVED THIS IS AN ELECTRONICALLY GENERATED DOCUMENT - DO NOT SCALE THIS PRINT							RFP	CAD FILE ee7308	SIZE A	DRAWING NO. EE7308	PAGE OF 5	REV. 5
							DIST WP					



**P.O. BOX 8003
WAUSAU, WI 54401-8003
PH. 715-675-3311**

CERTIFICATION DATA SHEET

CUSTOMER:
ORDER #:
CONN. DIAGRAM: A-EE7308
OUTLINE: 037657-912
WINDING #: K2152227 2

CUSTOMER PO#:
MODEL #: 215TTFND6807 AA
CUSTOMER PART #:
MOUNTING: F1/F2 CAPABLE

TYPICAL MOTOR PERFORMANCE DATA

HP	kW	SYNC. RPM	F.L. RPM	FRAME	ENCLOSURE	KVA CODE	DESIGN
10	7.50	3600	3520	215T	TEFC	H	B

PH	Hz	VOLTS	AMPS	START TYPE	DUTY	INSL	S.F.	AMB°C
3	60	230/460	23.8/11.9	LINE OR INVERTER	CONTINUOUS	F3	1.15	40

FULL LOAD EFF:	90.2	3/4 LOAD EFF:	90.6	1/2 LOAD EFF:	89.8	GTD. EFF		ELEC. TYPE	
FULL LOAD PF:	87.1	3/4 LOAD PF:	83.3	1/2 LOAD PF:	74.4	88.5		SQ CAGE INV RATED	

F.L. TORQUE	LOCKED ROTOR AMPS	L.R. TORQUE	B.D. TORQUE	F.L. RISE°C
14.9 LB-FT	156 / 78	29 LB-FT 195 %	46 LB-FT 309 %	60

SOUND PRESSURE @ 3 FT.	SOUND POWER	ROTOR WK^2	MAX. WK^2	SAFE STALL TIME	STARTS / HOUR	APPROX. MOTOR WGT
72 dBA	82 dBA	0.55 LB-FT^2	18 LB-FT^2	15 SEC.	2	120 LBS.

***** SUPPLEMENTAL INFORMATION *****

DE BRACKET TYPE	ODE BRACKET TYPE	MOUNT TYPE	ORIENTATION	SEVERE DUTY	HAZARDOUS LOCATION	DRIP COVER	SCREENS	PAINT
STANDARD	STANDARD	RIGID	HORIZONTAL	PREMIUM SEVERE DUTY	DIVISION 2 T2B	FALSE	NONE	BLUE (EPOXY)

BEARINGS		GREASE	SHAFT TYPE	SPECIAL DE	SPECIAL ODE	SHAFT MATERIAL	FRAME MATERIAL
DE	ODE						
BALL	BALL	POLYREX EM	T	NONE	NONE	1144 STRESSPROOF (C-223)	CAST IRON
6307	6208						

THERMO-PROTECTORS				THERMISTORS	CONTROL	SPACE HEATERS
THERMOSTATS	PROTECTORS	WDG RTDs	BRG RTDs			
NONE	NOT	NONE	NONE	NONE	FALSE	NONE VOLTS

*
N
O
T
E
S
*

INVERTER TORQUE: CONSTANT 20:1
INV. HP SPEED RANGE: 1.5 X BASE SPEED
ENCODER: NONE NONE NONE NONE NONE PPR
BRAKE: NONE NONE NONE P/N NONE NONE NONE NONE FT-LB NONE V NONE Hz

PREPARED BY: Dinesh
Suddula **DATE:**
02/14/2019 02:52:23 AM
FORM 3531 REV.3 02/07/99
** Subject to change without notice.

Data Sheet

215TTFND6807

Date: 1/4/2019
 Customer: _____
 Attention: _____
 Submitted by: FAREEDA DUDEKULA



Submittal

Data @ 460 V

Motor Load Data

Load	0%	25%	50%	75%	100%	115%	125%	LR
Current (Amps)	4.4	5.1	7.0	9.3	11.9	13.4	14.7	78.0
Torque (ft-lb)	0.00	3.7	7.4	11.1	14.9	17.2	18.8	29.0
RPM	3600	3580	3560	3540	3520	3,515	3495	0
Efficiency (%)		84.8	89.8	90.6	90.2	90.0	89.2	
P.F. (%)	8.6	54.1	74.4	83.3	87.1	89.5	89.1	40.0

Motor Speed Data

	LR	Pull-Up	BD	Rated	Idle
Speed (RPM)	0	1800	3065	3520	3600
Current (Amps)	78.0	72.0	50.0	11.9	4.4
Torque (ft-lb)	29.0	27.0	46.0	14.9	0.00

Information Block

HP	10.0			
Sync. RPM	3600			
Frame	215			
Enclosure	TEFC			
Construction	TFN			
Voltage	230/460 V			
Frequency	60 Hz			
Design	B			
LR Code letter	H			
Service Factor	1.15			
Temp Rise @ FL	60 °C			
Duty	CONT			
Ambient	40 °C			
Elevation	1,000 feet			
Rotor/Shaft wk ²	0.55 Lb-Ft ²			
Ref Wdg	K2152227 NONE			
Sound Pressure @ 1M	72 dBA			
VFD Rating	CONSTANT 20:1			
Outline Dwg	037657-912			
Conn. Diag	A-EE7308			
Additional Specifications:				
0				
0				
EQUIV CKT (OHMS / PHASE)				
R1	R2	X1	X2	Xm
0.8280	0.5020	1.9740	1.3470	58.5630

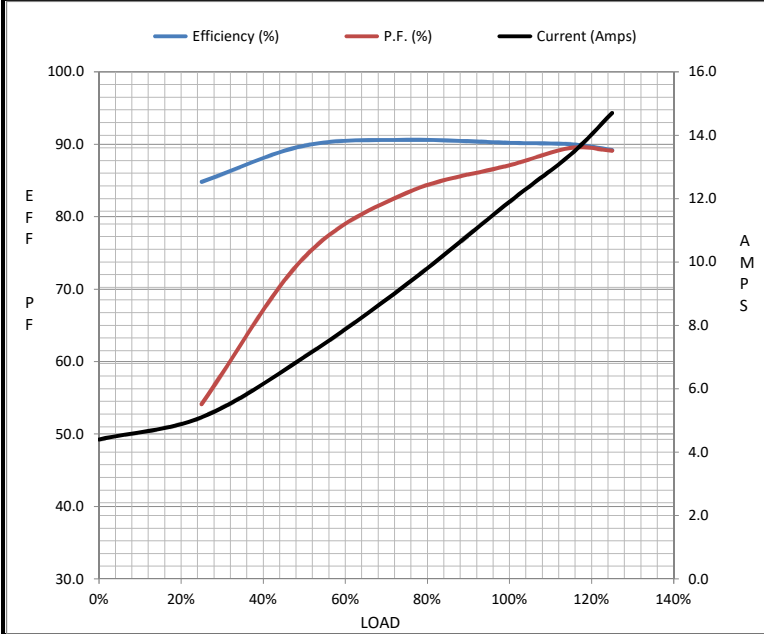

Speed - Torque Curve

