

# PRODUCT INFORMATION PACKET

Model No: 215TTFN6546

Catalog No: U870A

XRI®-SD Severe Duty Motor, 10 & 7.5 HP, 3 Ph, 60 & 50 Hz, 230/460 & 190/380 V, 1800 & 1500 RPM,  
215T Frame, TEFC



Regal and Marathon are trademarks of Regal Rexnord Corporation or one of its affiliated companies.

©2023 Regal Rexnord Corporation, All Rights Reserved. MC017097E

### Nameplate Specifications

Phase	<b>3</b>	Output HP	<b>10 &amp; 7.50 Hp</b>
Output KW	<b>7.5 &amp; 5.6 kW</b>	Voltage	<b>230/460 &amp; 190/380 V</b>
Speed	<b>1765 &amp; 1470 rpm</b>	Service Factor	<b>1.15 &amp; 1.15</b>
Frame	<b>215T</b>	Enclosure	<b>Totally Enclosed Fan Cooled</b>
Thermal Protection	<b>No Protection</b>	Efficiency	<b>91.7 &amp; 91.5 %</b>
Ambient Temperature	<b>40 °C</b>	Frequency	<b>60 &amp; 50 Hz</b>
Current	<b>25/12.5 &amp; 23/11.5 A</b>	Power Factor	<b>82</b>
Duty	<b>Continuous</b>	Insulation Class	<b>F</b>
Design Code	<b>B</b>	KVA Code	<b>G</b>
Drive End Bearing Size	<b>6307</b>	Opp Drive End Bearing Size	<b>6208</b>
UL	<b>Recognized</b>	CSA	<b>Y</b>
CE	<b>Y</b>	IP Code	<b>55</b>
Number of Speeds	<b>1</b>		

### Technical Specifications

Electrical Type	<b>Squirrel Cage Induction Run</b>	Starting Method	<b>Across The Line</b>
Poles	<b>4</b>	Rotation	<b>Reversible</b>
Resistance Main	<b>.894 Ohms</b>	Mounting	<b>Rigid Base</b>
Motor Orientation	<b>Horizontal</b>	Drive End Bearing	<b>Ball</b>
Opp Drive End Bearing	<b>Ball</b>	Frame Material	<b>Cast Iron</b>
Shaft Type	<b>T</b>	Overall Length	<b>22.63 in</b>
Frame Length	<b>12.12 in</b>	Shaft Diameter	<b>1.375 in</b>
Shaft Extension	<b>3.48 in</b>	Assembly/Box Mounting	<b>F1/F2 Capable</b>
Outline Drawing	<b>037657-1212</b>	Connection Drawing	<b>A-EE7308</b>

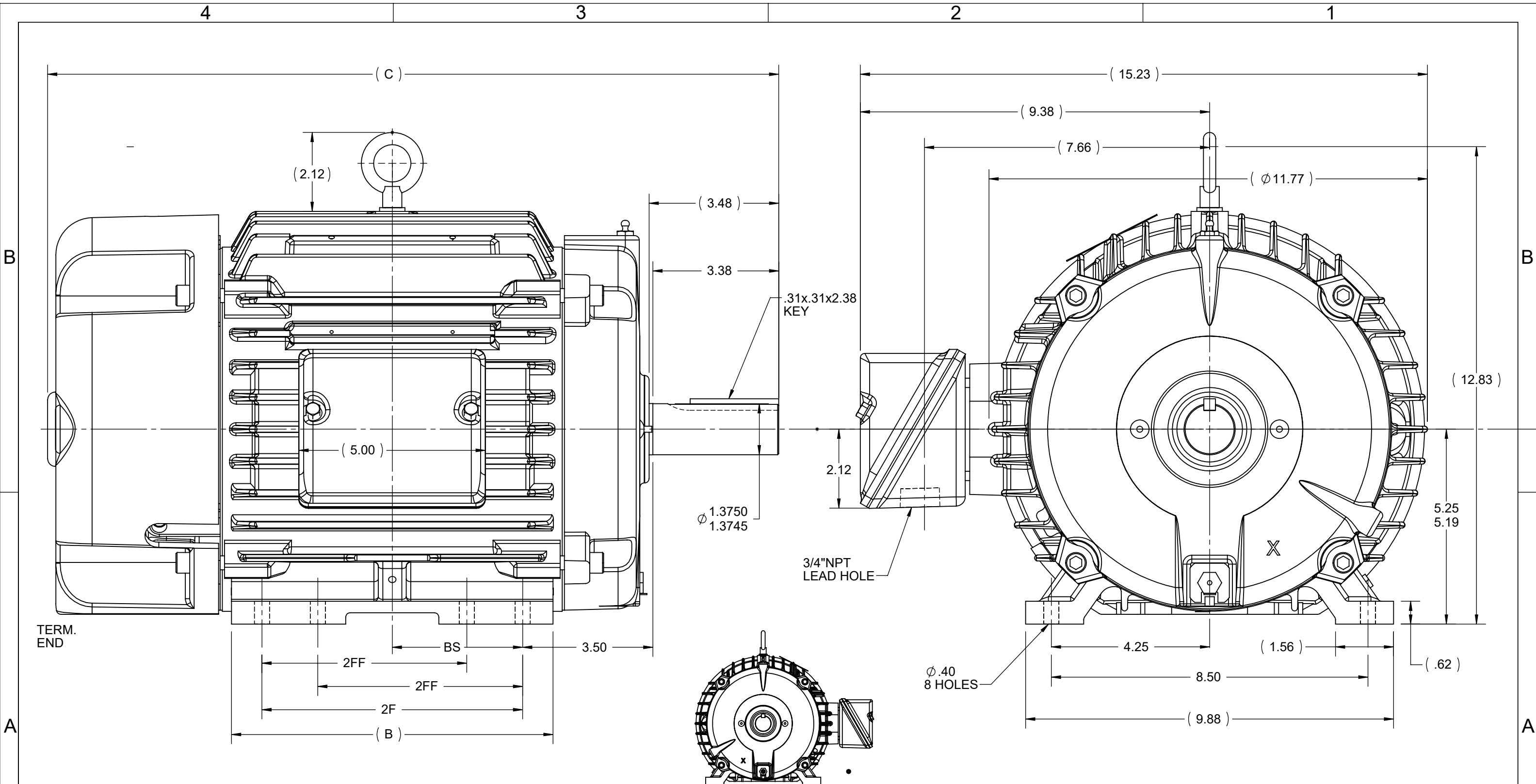

- NOTES:
1. CONDUIT BOX CAN BE ROTATED IN 90° STEPS.
  2. CONDUIT BOX CAN BE MOUNTED IN OPPOSITE SIDE BY REMOVING BRACKETS AND TURNING FRAME 180°.
  3. NAMEPLATE TO BE READ FROM CONDUIT BOX SIDE OF MOTOR.

1212	213/215	22.63	11.76	10	7	5
912	213/215	19.63	8.63	7	5.5	3.5
DASH	FRAME	C	B	2F	2FF	BS

DRAWING REVISION F	REVISION BY PB	REV DATE/© DATE 06/23/22	TOLERANCES (EXCEPT AS NOTED): DEC. INCH mm ANGLE .X ±0.1 [±3] ±7' 30" .XX ±0.03 [±0.8] .XXX ±0.005 [±0.13] .XXXX ±0.0005 [±0.013] REMOVE BURRS & BREAK SHARP EDGES: .003/.015 [.08/.38] X 45° CORNER FILLETS: R.02 [.5] MACHINED SURFACES: 200 INCH/mm 5.1 mm DIMENSIONS IN [BRACKETS] ARE FOR REFERENCE ONLY	DRAWN BY AK	<b>Regal Rexnord</b> Regal Beloit America, Inc.
REQUEST NUMBER NMR-0214901	APPROVED BY PB	DATE 06/23/22		DATE 09/09/2009	
REQUEST NUMBER DESCRIPTION UPDATE WITH NEW TEMPLATE				APPROVED BY	DESCRIPTION OUTLINE
COPYRIGHT (PER REVISION DATE) REGAL BELOIT AMERICA, INC. ALL RIGHTS RESERVED. PROPRIETARY AND CONFIDENTIAL INFORMATION - THIS DOCUMENT IS THE PROPERTY OF REGAL BELOIT AMERICA, INC. ("OWNER") AND CONTAINS OWNER'S PROPRIETARY INFORMATION. ANY PERSON, CORPORATION OR OTHER FIRM RECEIVING IT IS DEEMED, BY RECEIVING IT, TO AGREE THAT IT, AND/OR ANY PART OF IT, SHALL NOT BE DISCLOSED TO ANY PERSON, CORPORATION OR OTHER ENTITY, DUPLICATED, AND/OR USED, EXCEPT AS EXPRESSLY APPROVED IN WRITING IN ADVANCE BY OWNER. THIS DOCUMENT SHALL BE RETURNED TO OWNER UPON REQUEST. IT MAY BE SUBJECT TO CERTAIN RESTRICTIONS UNDER APPLICABLE EXPORT CONTROL LAWS AND REGULATIONS.				DATE	210T FR.-TEFC-BB-STD.
				REFERENCE	MATERIAL
				THIRD ANGLE PROJECTION	PROCESS/FINISH
				SIZE B	DRAWING NUMBER 037657
					SHEET 1 OF 1



NO.	REVISION	BY & DATE	CHK	ANG	TOLERANCES UNLESS SPECIFIED		FINISH	DRAWN RM 11/20/1990				
					DEC.	INCHES						
5	CHG TO REGAL LOGO	SL 09/10/2015	AB					CHK ML 11/21/1990				
4	REVISED IEC NOTATIONS	MSG 11/15/2011	CMN	.X	±.1			APPD SAS 04/24/2003				
3	ADDED IEC NOTATIONS... (U1), (V1) ETC. MU95194	MSG 5/10/2010	MJS	.XX	±.02		TITLE CONNECTION DIAGRAM	SCALE 1=1				
2	ADDED THE OPTIONAL CORD CONNECTION MU46318	RDH 04/24/2003	DRS	.XXX	±.005		3Ø - DUAL VOLTAGE MOTOR	REF				
1	REDRAWN	RM 11/20/1990		.XXXX	±.0005		MAT'L.	FMF				
					±7'30"			PREV				
THIS DRAWING IN DESIGN AND DETAIL IS OUR PROPERTY AND MUST NOT BE USED EXCEPT IN CONNECTION WITH OUR WORK ALL RIGHTS OF DESIGN AND INVENTION ARE RESERVED THIS IS AN ELECTRONICALLY GENERATED DOCUMENT - DO NOT SCALE THIS PRINT							RFP	CAD FILE ee7308	SIZE A	DRAWING NO. EE7308	PAGE OF 5	REV. 5
							DIST WP					

**CERTIFICATION DATA SHEET**

**Model#:** 215TTFN6546 AA      **WINDING#:** K2154249 NONE 1  
**CONN. DIAGRAM:** A-EE7308      **ASSEMBLY:** F1/F2 CAPABLE  
**OUTLINE:** 037657-1212

**TYPICAL MOTOR PERFORMANCE DATA**

HP	KW	SYNC. RPM	F.L. RPM	FRAME	ENCLOSURE	KVA CODE	DESIGN
10&7 1/2	7.50&5.60	1800	1765&1470	215T	TEFC	G	B

PH	Hz	VOLTS	FL AMPS	START TYPE	DUTY	INSL	S.F	AMB°C	ELEVATION
3	60/50	230/460#190/ 380	25/12.5&23/11 .5	ACROSS THE LINE	CONTINUOU S	F3	1.15/1.15	40	3300

FULL LOAD EFF: 91.7&91.5	3/4 LOAD EFF: 91.7	1/2 LOAD EFF: 91	GTD. EFF	ELEC. TYPE	NO LOAD AMPS
FULL LOAD PF: 82&81	3/4 LOAD PF: 78	1/2 LOAD PF: 68	91	SQ CAGE IND RUN	10 / 5

F.L. TORQUE	LOCKED ROTOR AMPS	L.R. TORQUE	B.D. TORQUE	F.L. RISE°C
29.8 LB-FT	160 / 80	60 LB-FT 201	81 LB-FT 272	55

SOUND PRESSURE @ 3 FT.	SOUND POWER	ROTOR WK^2	MAX. WK^2	SAFE STALL TIME	STARTS /HOUR	APPROX. MOTOR WGT
62 dBA	72 dBA	1.2 LB-FT^2	192 LB-FT^2	20 SEC.	2	240 LBS.

**\*\*\* SUPPLEMENTAL INFORMATION \*\*\***

DE BRACKET TYPE	ODE BRACKET TYPE	MOUNT TYPE	ORIENTATION	SEVERE DUTY	HAZARDOUS LOCATION	DRIP COVER	SCREENS	PAINT
STANDARD	STANDARD	RIGID	HORIZONTAL	PREMIUM SEVERE DUTY	NONE	FALSE	NONE	BLUE (EPOXY)

BEARINGS		GREASE	SHAFT TYPE	SPECIAL DE	SPECIAL ODE	SHAFT MATERIAL	FRAME MATERIAL
DE	OPE						
BALL	BALL	POLYREX EM	T	NONE	NONE	1045 HOT ROLLED (C-204)	CAST IRON
6307	6208						

THERMO-PROTECTORS				THERMISTORS	CONTROL	SPACE /n HEATERS
THERMOSTATS	PROTECTORS	WDG RTDs	BRG RTDs			
NONE	NOT	NONE	NONE	NONE	FALSE	NONE VOLTS

If Inverter equals NONE, contact factory for further information

\*  
N  
O  
T  
E  
S  
\*

INVERTER TORQUE: NONE
INV. HP SPEED RANGE: NONE
ENCODER: NONE
NONE NONE
NONE NONE PPR
BRAKE: NONE NONE
NONE P/N NONE
NONE NONE
- FT-LB NONE V NONE Hz

DATE: 06/22/2017 07:58:36 AM  
 FORM 3531 REV.3 02/07/99  
 \*\* Subject to change without notice.

Data Sheet

Date: 20-06-2017  
 Customer: \_\_\_\_\_  
 Attention: \_\_\_\_\_  
 Submitted by: FAREEDA DUDEKULA



215TTFN6546

Submittal

Data @ 460 V

Motor Load Data

Load	0%	25%	50%	75%	100%	115%	125%	LR
Current (Amps)	5.0	5.5	7.5	10.0	12.5	14.0	15.5	80.0
Torque (ft-lb)	0.00	7.5	14.5	22.0	29.8	34.5	37.5	60.0
RPM	1800	1790	1785	1775	1765	1,755	1750	0
Efficiency (%)		87.5	91.0	91.7	91.7	91.0	90.2	
P.F. (%)	6.5	47.0	68.0	78.0	82.0	83.5	83.5	42.0

Motor Speed Data

	LR	Pull-Up	BD	Rated	Idle
Speed (RPM)	0	900	1675	1765	1800
Current (Amps)	80.0	72.0	46.0	12.5	5.0
Torque (ft-lb)	60.0	54.0	81.0	29.8	0.00

Information Block				
HP	10.0			
Sync. RPM	1800			
Frame	215			
Enclosure	TEFC			
Construction	TFN			
Voltage	230/460#190/38(V)			
Frequency	60 Hz			
Design	B			
LR Code letter	G			
Service Factor	1.15			
Temp Rise @ FL	55 ° C			
Duty	CONT			
Ambient	40 ° C			
Elevation	1,000 feet			
Rotor/Shaft wk <sup>2</sup>	1.20 Lb-Ft <sup>2</sup>			
Ref Wdg	K2154249 NONE			
Sound Pressure @ 1M	62 dBA			
VFD Rating	NONE			
Outline Dwg	037657-1212			
Conn. Diag	A-EE7308			
Additional Specifications:				
0				
365THFS8036				
EQUIV CKT (OHMS / PHASE)				
R1	R2	X1	X2	Xm
0.5400	0.4880	2.0930	3.2090	51.1200

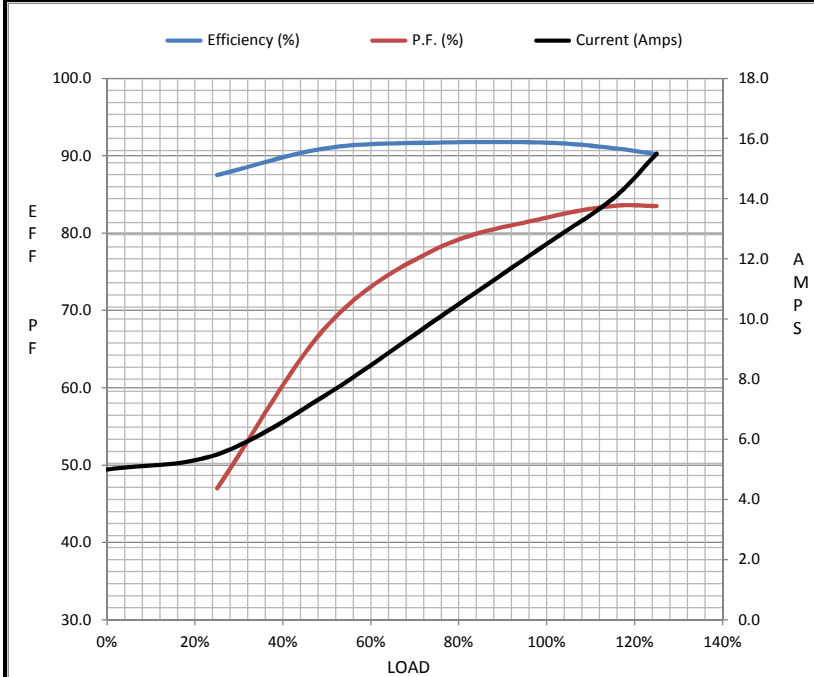

Speed - Torque Curve

