

PRODUCT INFORMATION PACKET

Model No: 213TTTL7034

Catalog No: C407

Brake Motor, 7.50 & 5 HP, 3 Ph, 60 & 50 Hz, 230/460 & 190/380 V, 1800 & 1500 RPM, 213TC Frame, TENV



Regal and Marathon are trademarks of Regal Rexnord Corporation or one of its affiliated companies.

©2023 Regal Rexnord Corporation, All Rights Reserved. MC017097E

Nameplate Specifications

Phase	3	Output HP	7.50 & 5 Hp
Output KW	5.6 & 3.7 kW	Voltage	230/460 & 190/380 V
Speed	1770 & 1470 rpm	Service Factor	1.0 & 1.0
Frame	213TC	Enclosure	Totally Enclosed Non Ventilated
Thermal Protection	No Protection	Efficiency	91 & 89.5 %
Ambient Temperature	40 °C	Frequency	60 & 50 Hz
Current	19.2/9.6 & 16.4/8.2 A	Power Factor	80
Duty	Continuous	Insulation Class	F
Design Code	B	KVA Code	H
Drive End Bearing Size	6309	Opp Drive End Bearing Size	6307
UL	Recognized	CSA	Y
CE	Y	IP Code	43
Number of Speeds	1		

Technical Specifications

Electrical Type	Squirrel Cage Induction Run	Starting Method	Across The Line
Poles	4	Rotation	Reversible
Resistance Main	1.17 Ohms	Mounting	Rigid Base
Motor Orientation	Horizontal	Drive End Bearing	Ball
Opp Drive End Bearing	Ball	Frame Material	Aluminum
Shaft Type	T	Overall Length	27.04 in
Frame Length	11.15 in	Shaft Diameter	1.375 in
Shaft Extension	3.38 in	Assembly/Box Mounting	F1/F2 Capable
Connection Drawing	A-EE7308	Outline Drawing	B-SS330106-1115

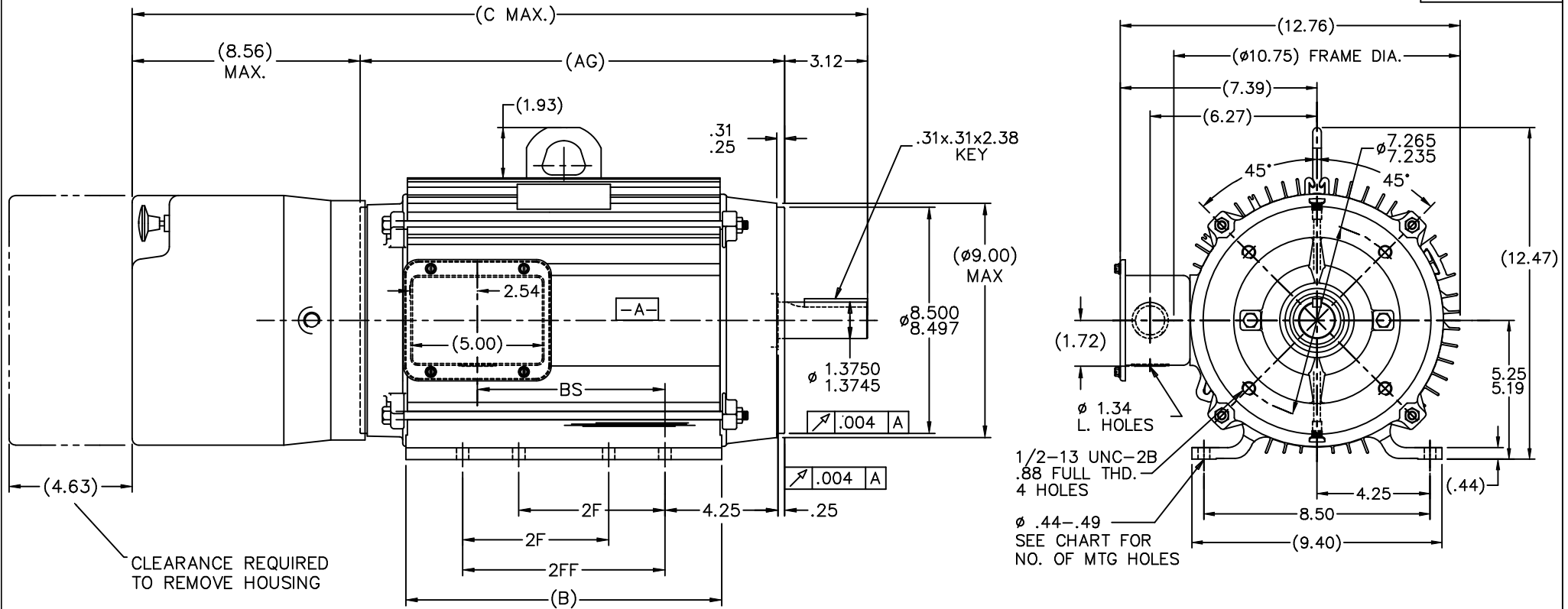

- NOTES:
 1. BOX CAN BE ROTATED IN 180° STEPS.
 2. NAMEPLATE TO BE READ FROM CONDUIT BOX SIDE OF MOTOR.
 3. SEE CHART FOR F2 CAPABILITY. IF YES, BOX CAN BE MOUNTED ON OPPOSITE SIDE BY REMOVING BRACKETS AND TURNING FRAME 180°

DASH	FR.	B	C	2F	2FF	AG	BS	F2 CAPABLE	NO. OF MTG HOLES
875	213	8.87	24.64	5.50	—	12.96	4.05	YES	8
950	213	9.62	25.39	5.50	—	13.71	4.80	NO	4
1025	213	10.37	26.14	5.50	—	14.46	5.55	NO	4
1025	215	10.37	26.14	7.00	—	14.46	5.55	YES	8
1115	213/215	11.27	27.04	5.50	/7.00	15.36	6.45	YES	8
1175	213	11.87	27.64	5.50	—	15.96	7.05	YES	8
1175	215	11.87	27.64	7.00	—	15.96	7.05	NO	4
1275	213	12.87	28.64	5.50	—	16.96	8.05	YES	8
1275	215	12.87	28.64	7.00	—	16.96	8.05	YES	8

		TOLERANCES UNLESS SPECIFIED		REGAL-BELOIT CORPORATION		DRAWING/MLIST 03-02-05	
		DEC.	INCHES	REGAL-BELOIT CORPORATION		CHK	ML 10-11-05
		.X	±.1	TITLE OUTLINE		APPD	GK 10-11-05
		.XX	±.03	210 TC FR. - STEARNS 87,000 SERIES BRK		SCALE	9-32
		.XXX	±.005	MATL		REF	
1	ADDED "2FF" COLUMN CN40215	JJB	06/01/2006	.XXXX	±.0005	FMF	
NO.	REVISION	BY & DATE	CHK	ANG	FINISH	PREV	
				±1/2"			
THIS DRAWING IN DESIGN AND DETAIL IS OUR PROPERTY AND MUST NOT BE USED EXCEPT IN CONNECTION WITH OUR WORK ALL RIGHTS OF DESIGN AND INVENTION ARE RESERVED THIS IS AN ELECTRONICALLY GENERATED DOCUMENT - DO NOT SCALE THIS PRINT						RFP	
						CAD FILE	ss330106
						SIZE	DRAWING NO. PAGE 1 OF 1 REV.
						B	SS330106 1



NO.	REVISION	BY & DATE	CHK	ANG	TOLERANCES UNLESS SPECIFIED		FINISH	DRAWN RM	ML	REV.	
					DEC.	INCHES					
5	CHG TO REGAL LOGO	SL 09/10/2015	AB					11/20/1990			
4	REVISED IEC NOTATIONS	MSG 11/15/2011	CMN	.X	±.1				11/21/1990		
3	ADDED IEC NOTATIONS... (U1), (V1) ETC. MU95194	MSG 5/10/2010	MJS	.XX	±.02				04/24/2003		
2	ADDED THE OPTIONAL CORD CONNECTION MU46318	RDH 04/24/2003	DRS	.XXX	±.005						
1	REDRAWN	RM 11/20/1990		.XXXX	±.0005						
					±7'30"						
THIS DRAWING IN DESIGN AND DETAIL IS OUR PROPERTY AND MUST NOT BE USED EXCEPT IN CONNECTION WITH OUR WORK ALL RIGHTS OF DESIGN AND INVENTION ARE RESERVED THIS IS AN ELECTRONICALLY GENERATED DOCUMENT - DO NOT SCALE THIS PRINT							RFP	CAD FILE ee7308	SIZE A	DRAWING NO. EE7308	PAGE OF 5
							DIST WP				



TITLE CONNECTION DIAGRAM
3Ø - DUAL VOLTAGE MOTOR