

PRODUCT INFORMATION PACKET

Model No: 213TTDW7053

Catalog No: H955

50 Hz Motor, 7.50 HP, 3 Ph, 50 Hz, 190-200-208/380-400-415 V, 1500 RPM, 213T Frame, DP



Regal and Marathon are trademarks of Regal Rexnord Corporation or one of its affiliated companies.
©2023 Regal Rexnord Corporation, All Rights Reserved. MC017097E

Nameplate Specifications

Phase	3	Output HP	7.50 Hp
Output KW	5.6 kW	Voltage	190-200-208/380-400-415 V
Speed	1460 rpm	Service Factor	1.15
Frame	213T	Enclosure	Drip Proof
Thermal Protection	No Protection	Efficiency	87.7 %
Ambient Temperature	40 °C	Frequency	50 Hz
Current	23.2-23.0-22.6/11.6- A	Power Factor	79
Duty	Continuous	Insulation Class	F
Design Code	B	KVA Code	J
Drive End Bearing Size	6307	Opp Drive End Bearing Size	6206
UL	Recognized	CSA	Y
CE	Y	IP Code	22
Number of Speeds	1		

Technical Specifications

Electrical Type	Squirrel Cage Induction Run	Starting Method	Part Wdg Start Low Volt Only & Wye Start Delta Run
Poles	4	Rotation	Reversible
Resistance Main	1.39 Ohms	Mounting	Rigid Base
Motor Orientation	Horizontal	Drive End Bearing	Ball
Opp Drive End Bearing	Ball	Frame Material	Rolled Steel
Shaft Type	T	Overall Length	17.30 in
Frame Length	11.15 in	Shaft Diameter	1.375 in
Shaft Extension	3.47 in	Assembly/Box Mounting	F1/F2 CAPABLE
Outline Drawing	A-SS86500-1115	Connection Drawing	A-EE7358

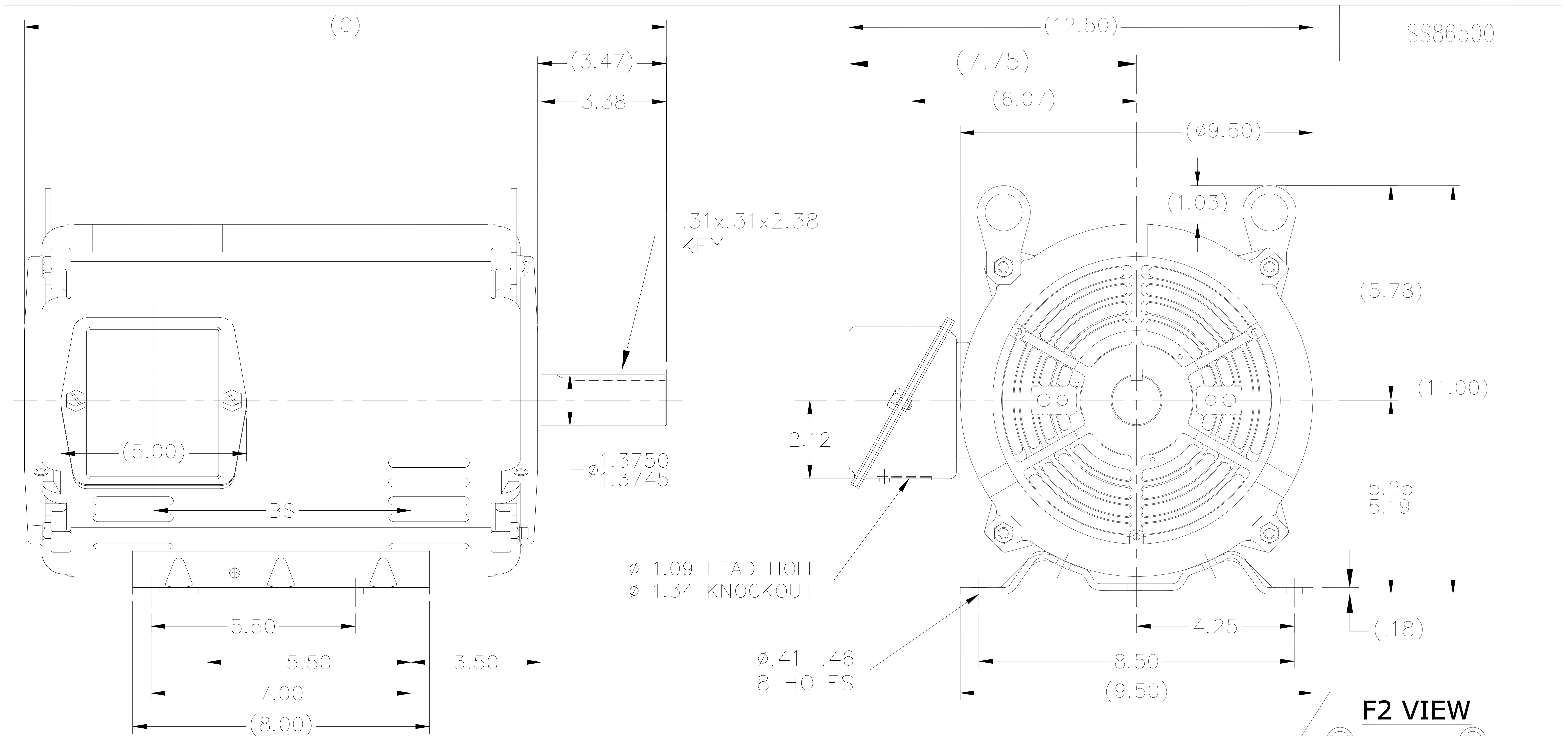

SS86500

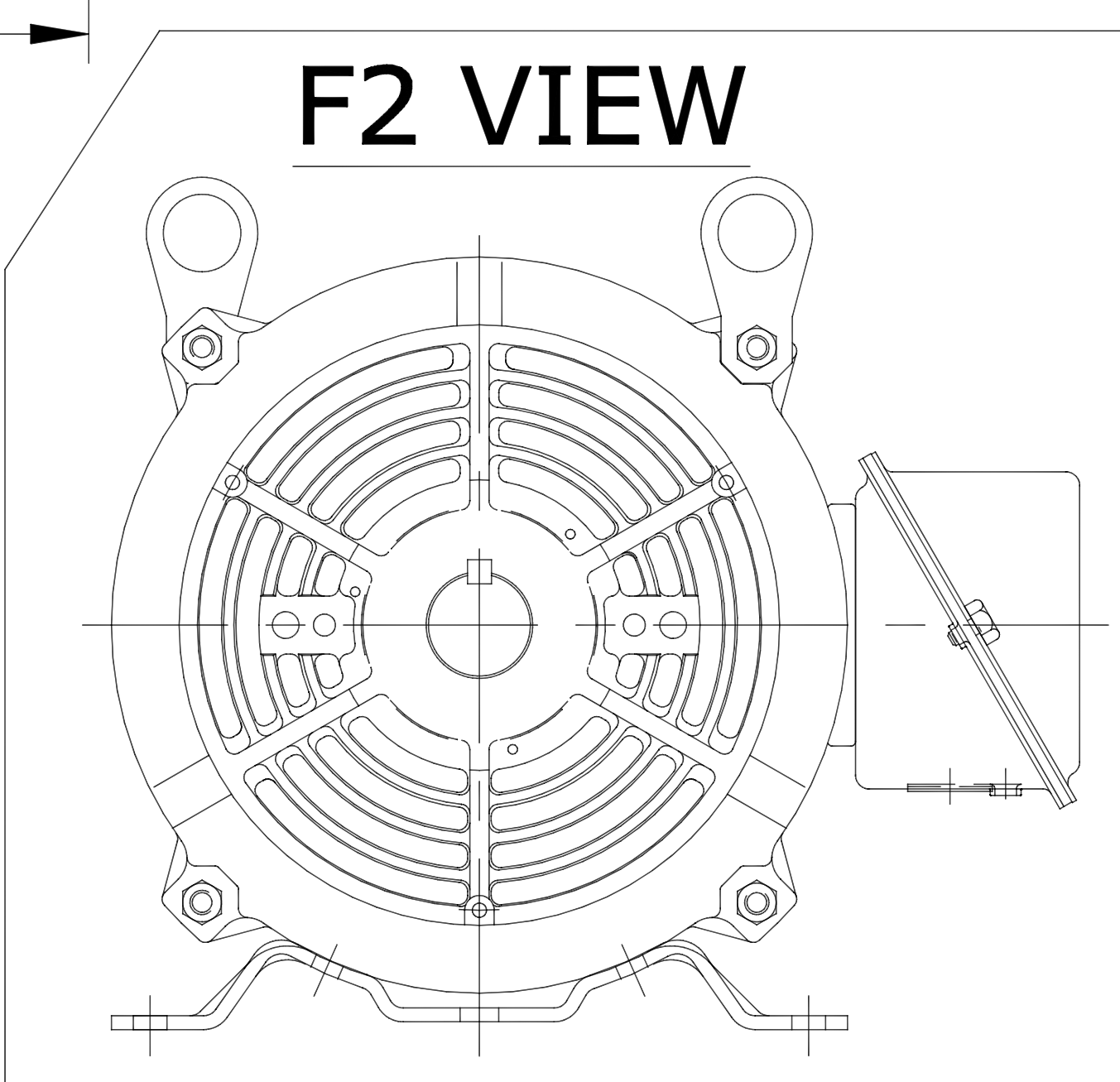

- NOTES:
1. NAMEPLATE TO BE READ FROM C'BOX SIDE OF MOTOR.
 2. BOX CAN BE MOUNTED IN 90° STEPS.
 3. BOX CAN BE MOUNTED ON OPPOSITE SIDE BY REMOVING BRACKETS AND TURNING FRAME 180°. (EXCEPT AS NOTED.)

DASH	FR.	C	BS	MOUNTING
1115	213/15T	17.30	6.93	F1/F2
1240	213/15T	18.55	8.18	F1 ONLY

14	TITLE BLOCK LOGO CHANGE PER ECO-0078542	MDV 06/09/2015	MDV	TOLERANCES UNLESS SPECIFIED		 Regal Beloit America, Inc.	DRAWN SMC 04-13-1993
13	FOR FRAME 11.15 MOUNTING NOTE ADDED	UD 12/13/12	SR	DEC.	INCHES		CHK MOL 04-04-1993
12	ADDED: F2 VIEW.	KVN 2/10/2009	SVL	.X	±.1		APPD DRN 04-13-1993
11	UPDATED DRAWING	TJW 04/27/2007		.XX	±.03	TITLE OUTLINE	SCALE 1=4
10	REM'VD. DASH 965 FROM SERIES CN38252	RWR 07-20-2004	ML	.XXX	±.005	210 FR. - BB - TS - DR. PR.	REF
9	REDRAWN IN AUTOCAD	TAT 06-29-2004	ML	.XXXX	±.0005	MAT'L.	FMF
NO.	REVISION	BY & DATE	CHK	ANG	±7'30"	FINISH	PREV

THIS DRAWING IN DESIGN AND DETAIL IS OUR PROPERTY AND MUST NOT BE USED EXCEPT IN CONNECTION WITH OUR WORK ALL RIGHTS OF DESIGN AND INVENTION ARE RESERVED THIS IS AN ELECTRONICALLY GENERATED DOCUMENT - DO NOT SCALE THIS PRINT

RFP	CAD FILE ss86500	SIZE A	DRAWING NO. SS86500	PAGE 1 OF 1	REV. 14
DIST LB					

HIGH VOLTAGE

WYE START

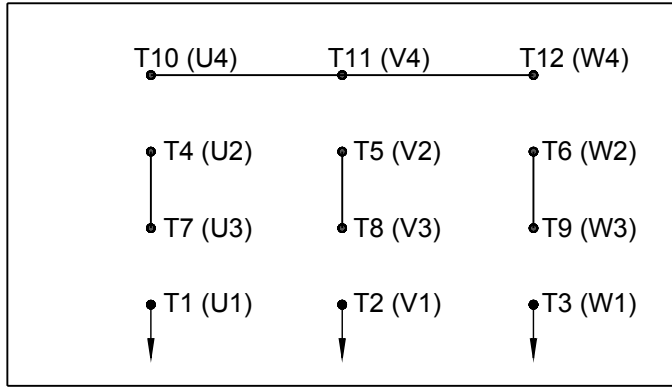

DELTA RUN

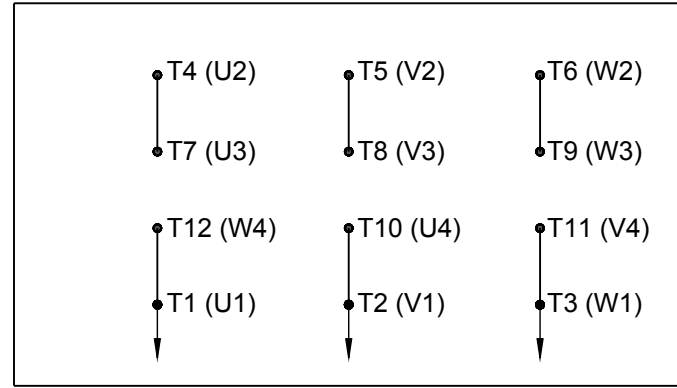

WYE START

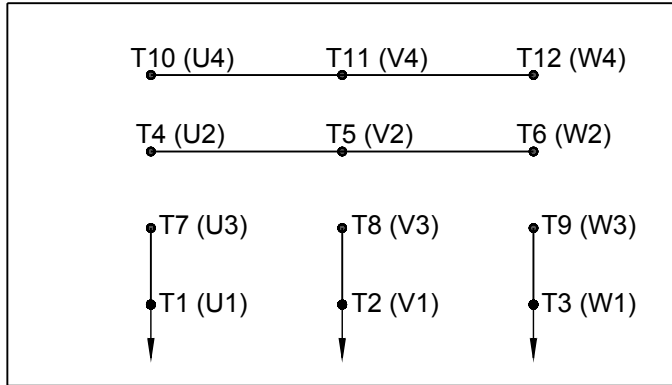

LOW VOLTAGE

DELTA RUN

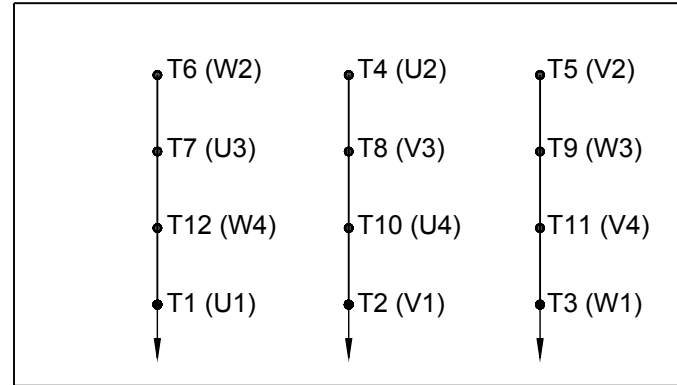

4/2 CKTY \triangle

DRAWING REVISION D	REVISION BY JWO	DATE 01-26-2016
ECO ECO-0092547	APPROVED BY TB	DATE 01-26-2016

ECO DESCRIPTION
ADDED IEC MARKINGS

COPYRIGHT REGAL BELOIT AMERICA, INC. ALL RIGHTS RESERVED. PROPRIETARY AND CONFIDENTIAL INFORMATION - THIS DOCUMENT IS THE PROPERTY OF REGAL BELOIT AMERICA, INC. ("OWNER") AND CONTAINS OWNER'S PROPRIETARY INFORMATION. ANY PERSON, CORPORATION OR OTHER FIRM RECEIVING IT IS DEEMED, BY RECEIVING IT, TO AGREE THAT IT, AND/OR ANY PART OF IT, SHALL NOT BE DISCLOSED TO ANY PERSON, CORPORATION OR OTHER ENTITY, DUPLICATED, AND/OR USED, EXCEPT AS EXPRESSLY APPROVED IN WRITING IN ADVANCE BY OWNER. THIS DOCUMENT SHALL BE RETURNED TO OWNER UPON REQUEST. IT MAY BE SUBJECT TO CERTAIN RESTRICTIONS UNDER APPLICABLE EXPORT CONTROL LAWS AND REGULATIONS.

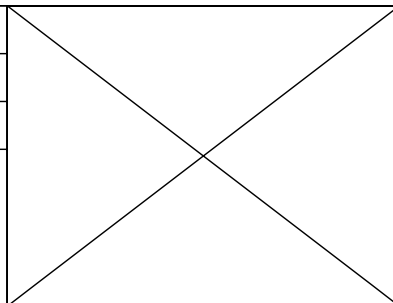

DRAWN BY BLR	Regal Beloit America, Inc.		
DATE 03-09-1998			
APPROVED BY GK	DESCRIPTION CONN DIAGRAM-EXTERNAL 12 LEAD - DUAL VOLT. - WYE START - DELTA RUN		
DATE 03-23-1998			
REFERENCE	MATERIAL	PROCESS/FINISH	
THIRD ANGLE PROJECTION	SIZE A	DRAWING NUMBER EE7358	SHEET 1 OF 1

DRAWN BY BLR	Regal Beloit America, Inc.		
DATE 03-09-1998			
APPROVED BY GK	DESCRIPTION CONN DIAGRAM-EXTERNAL 12 LEAD - DUAL VOLT. - WYE START - DELTA RUN		
DATE 03-23-1998			
REFERENCE	MATERIAL	PROCESS/FINISH	
THIRD ANGLE PROJECTION	SIZE A	DRAWING NUMBER EE7358	SHEET 1 OF 1

CERTIFICATION DATA SHEET

Model#: 213TTDW7053 BB
CONN. DIAGRAM: A-EE7358
OUTLINE: A-SS86500-1115

WINDING#: K2134219 NONE 2
ASSEMBLY: F1/F2 CAPABLE

TYPICAL MOTOR PERFORMANCE DATA

HP	KW	SYNC. RPM	F.L. RPM	FRAME	ENCLOSURE	KVA CODE	DESIGN
7 1/2	5.6	1500	1460	213T	DP	J	B

PH	Hz	VOLTS	FL AMPS	START TYPE	DUTY	INSL	S.F	AMB°C	ELEVATION
3	50	190-200- 208/380-400- 415	23.2-23- 22.6/11.6- 11.5-11.3	PWS(LV ONLY) & YDRUN	CONTINUOU S	F4	1.15	40	3300

FULL LOAD EFF: 87.7	3/4 LOAD EFF: 88	1/2 LOAD EFF: 85	GTD. EFF	ELEC. TYPE	NO LOAD AMPS
FULL LOAD PF: 79	3/4 LOAD PF: 73	1/2 LOAD PF: 62	85.5	SQ CAGE IND RUN	11.4 / 5.7

F.L. TORQUE	LOCKED ROTOR AMPS	L.R. TORQUE	B.D. TORQUE	F.L. RISE°C
27 LB-FT	166 / 83	61 LB-FT 226	88.5 LB-FT 328	32

SOUND PRESSURE @ 3 FT.	SOUND POWER	ROTOR WK^2	MAX. WK^2	SAFE STALL TIME	STARTS /HOUR	APPROX. MOTOR WGT
63 dBA	73 dBA	0.65 LB-FT^2	60 LB-FT^2	15 SEC.	2	100 LBS.

***** SUPPLEMENTAL INFORMATION *****

DE BRACKET TYPE	ODE BRACKET TYPE	MOUNT TYPE	ORIENTATION	SEVERE DUTY	HAZARDOUS LOCATION	DRIP COVER	SCREENS	PAINT
STANDARD	STANDARD	RIGID	HORIZONTAL	FALSE	NONE	FALSE	NONE	GRAY (ENAMEL)

BEARINGS		GREASE	SHAFT TYPE	SPECIAL DE	SPECIAL ODE	SHAFT MATERIAL	FRAME MATERIAL
DE	OPE						
BALL	BALL	POLYREX EM	T	NONE	NONE	AISI 1045 (C-240)	ROLLED STEEL
6307	6206						

THERMO-PROTECTORS				THERMISTORS	CONTROL	SPACE /n HEATERS
THERMOSTATS	PROTECTORS	WDG RTDs	BRG RTDs			
NONE	NOT	NONE	NONE	NONE	FALSE	NONE VOLTS

If Inverter equals NONE, contact factory for further information

*
N
O
T
E
S
*

INVERTER TORQUE: NONE
INV. HP SPEED RANGE: NONE
ENCODER: NONE
NONE NONE
NONE NONE PPR
BRAKE: NONE NONE
NONE P/N NONE
NONE NONE
- FT-LB NONE V NONE Hz

DATE: 06/22/2017 05:02:07 AM
 FORM 3531 REV.3 02/07/99
 ** Subject to change without notice.

Data Sheet

Date: 19-06-2017
Customer: _____
Attention: _____
Submitted by: FAREEDA DUDEKULA



213TTDW7053

Submittal

Data @ 415 V

Motor Load Data

Load	0%	25%	50%	75%	100%	115%	125%	LR
Current (Amps)	5.5	6.0	6.3	9.2	11.3	12.7	13.7	80.0
Torque (ft-lb)	0.00	6.6	13.5	20.0	27.0	31.1	34.0	61.0
RPM	1500	1490	1475	1470	1460	1,455	1445	0
Efficiency (%)		80.0	85.0	88.0	87.7	87.0	86.0	
P.F. (%)	9.3	41.0	62.0	73.0	79.0	81.5	82.0	51.0

Motor Speed Data

	LR	Pull-Up	BD	Rated	Idle
Speed (RPM)	0	600	1250	1460	1500
Current (Amps)	80.0	72.0	48.0	11.3	5.5
Torque (ft-lb)	61.0	55.0	88.5	27.0	0.00

Information Block				
HP	7.5			
Sync. RPM	1500			
Frame	213			
Enclosure	DP			
Construction	TDW			
Voltage	200-208/380-400 V			
Frequency	50 Hz			
Design	A			
LR Code letter	J			
Service Factor	1.15			
Temp Rise @ FL	32 ° C			
Duty	CONT			
Ambient	40 ° C			
Elevation	1,000 feet			
Rotor/Shaft wk ²	0.65 Lb-Ft ²			
Ref Wdg	K2134219 NONE			
Sound Pressure @ 1M	63 dBA			
VFD Rating	NONE			
Outline Dwg	A-SS86500-1115			
Conn. Diag	A-EE7358			
Additional Specifications:				
0				
365THFS8036				
EQUIV CKT (OHMS / PHASE)				
R1	R2	X1	X2	Xm
0.9030	0.7220	2.1670	3.1480	55.7280

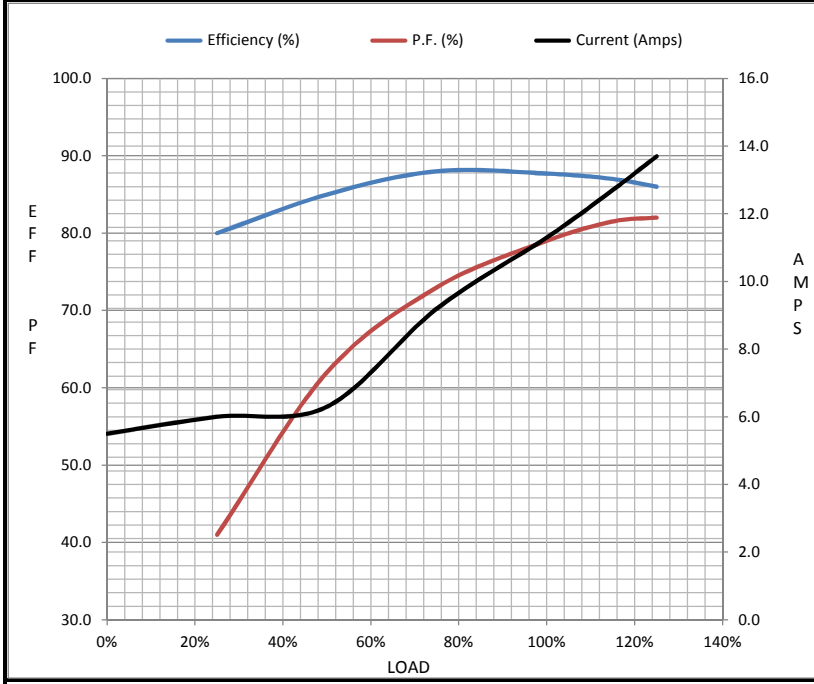

Speed - Torque Curve

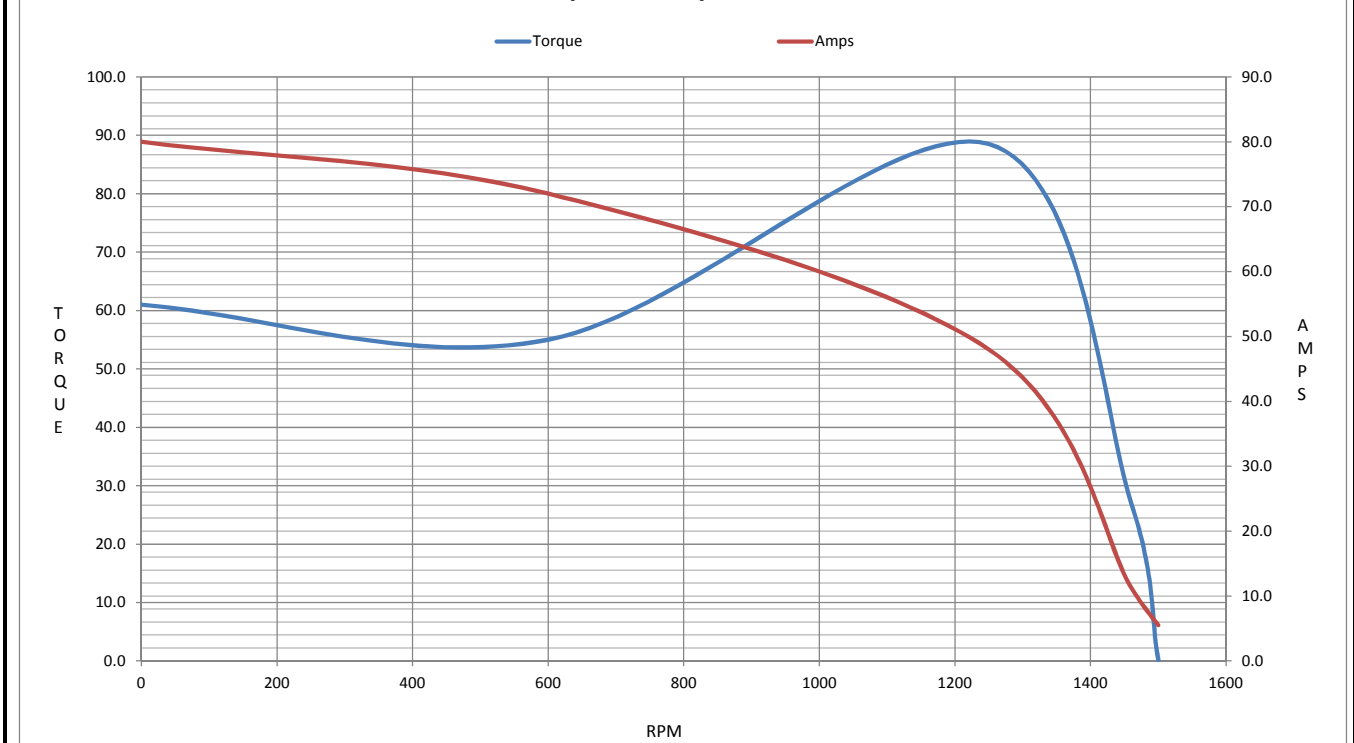

EC Declaration of Conformity

The undersigned representing
the manufacturer:

Regal Beloit America
100 East Randolph St.
Wausau, WI 54401

and the authorized representative
established within the Community:

Marathon Electric UK
6F Thistleton Road Ind. Estate
Market Overton
Oakham, Rutland LE15 7PP UK

are committed to providing customers with products that comply with applicable regulations and international protocols to which they are subject, including the requirements of the European Parliament Directive on the Harmonization of the laws relating to electrical equipment designed for use within certain voltage limits (2014/35/EU).

Regal Beloit America declares that the following product(s), to which this declaration relates, are in conformity with the relevant sections of the EC standards listed below.

This statement supersedes any statements previously issued pertaining to the product(s) listed below and is subject to change without notice.

Model No : 213TTDW7053

(Model No. may contain prefix and/or suffix characters)

Catalog No : H955

Rework No : N/A

Directives :

Low Voltage Directive 2014/35/EU

Harmonized Standards Used :

EN 60034-1: 2010 (IEC 60034-1: 2010)

EN 60034-5: 2001/A1:2007 (IEC 60034-5: 2000/A1:2006)

Authorized Representative:



Michael A. Logsdon
Vice President, Technology

Authorized Representative in the Community:



Julian Clark
Marketing Engineer

Created on 09/01/2022

CE 22