

# PRODUCT INFORMATION PACKET



Model No: 194288.00

Catalog No: 194288.00

SST Duck™ General Purpose Motor, 7.50 HP, 3 Ph, 60 Hz, 575 V, 3600 RPM, 213TC Frame, TEFC



Regal and Leeson are trademarks of Regal Rexnord Corporation or one of its affiliated companies.

©2022 Regal Rexnord Corporation, All Rights Reserved. MC017097E





**Nameplate Specifications**

Output HP	<b>7.50 Hp</b>	Output KW	<b>5.6 kW</b>
Frequency	<b>60 Hz</b>	Voltage	<b>575 V</b>
Current	<b>- A</b>	Service Factor	<b>1.15</b>
Phase	<b>3</b>	Duty	<b>Continuous</b>
Insulation Class	<b>F</b>	Design Code	<b>B</b>
KVA Code	<b>-</b>	Frame	<b>213TC</b>
Enclosure	<b>Totally Enclosed Fan Cooled</b>	Thermal Protection	<b>No Protection</b>
Ambient Temperature	<b>40 °C</b>	Drive End Bearing Size	<b>6306</b>
Opp Drive End Bearing Size	<b>6306</b>	UL	<b>Recognized</b>
CSA	<b>Y</b>	CE	<b>Y</b>
IP Code	<b>43</b>	Number of Speeds	<b>1</b>

**Technical Specifications**

Electrical Type	<b>Squirrel Cage Inverter Rated</b>	Starting Method	<b>Line Or Inverter</b>
Poles	<b>2</b>	Rotation	<b>Reversible</b>
Mounting	<b>Rigid Base</b>	Motor Orientation	<b>Horizontal</b>
Drive End Bearing	<b>Ball</b>	Opp Drive End Bearing	<b>Ball</b>
Frame Material	<b>Stainless Steel</b>	Shaft Type	<b>T</b>
Shaft Diameter	<b>1.375 in</b>	Assembly/Box Mounting	<b>F1 ONLY</b>
Inverter Load	<b>VARIABLE 10:1</b>		
Connection Drawing	<b>005010.01</b>	Outline Drawing	<b>OL210TCSST</b>

This is an uncontrolled document once printed or downloaded and is subject to change without notice. Date Created:11/30/2022

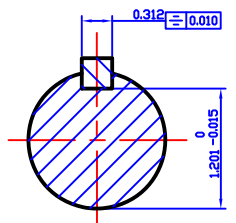
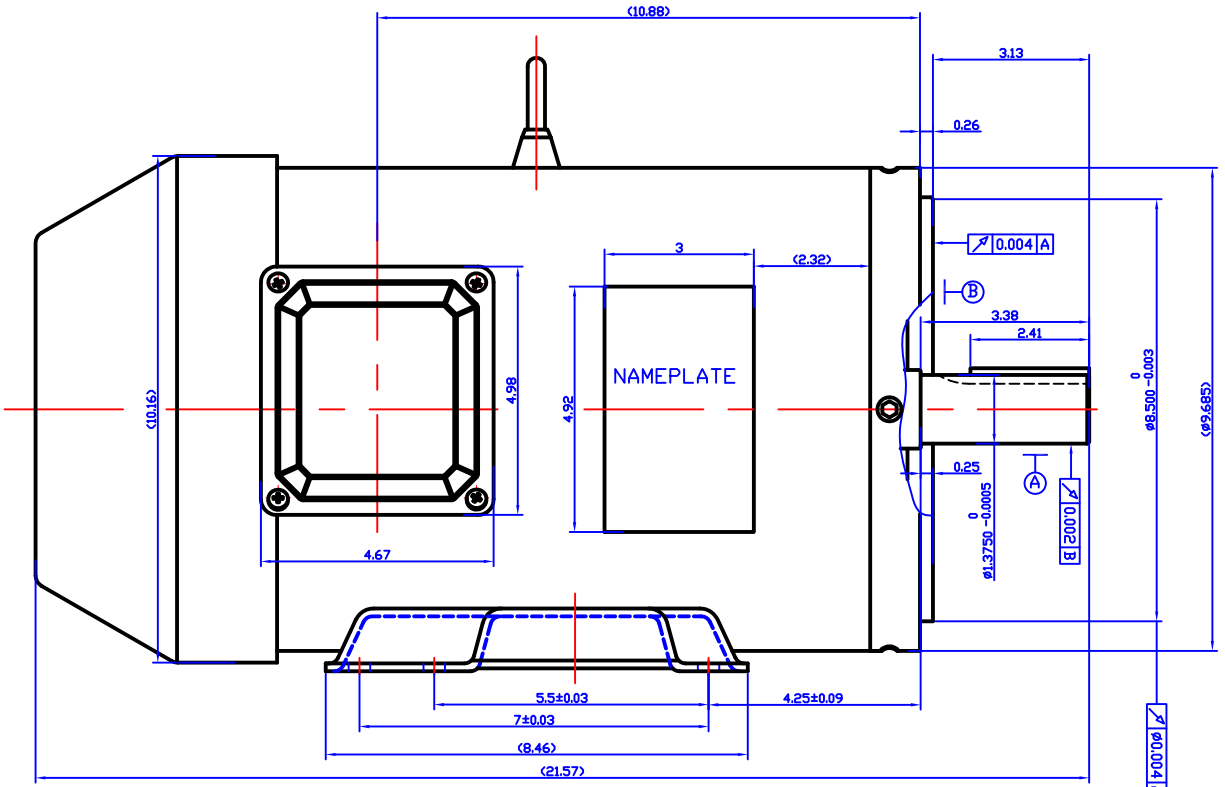
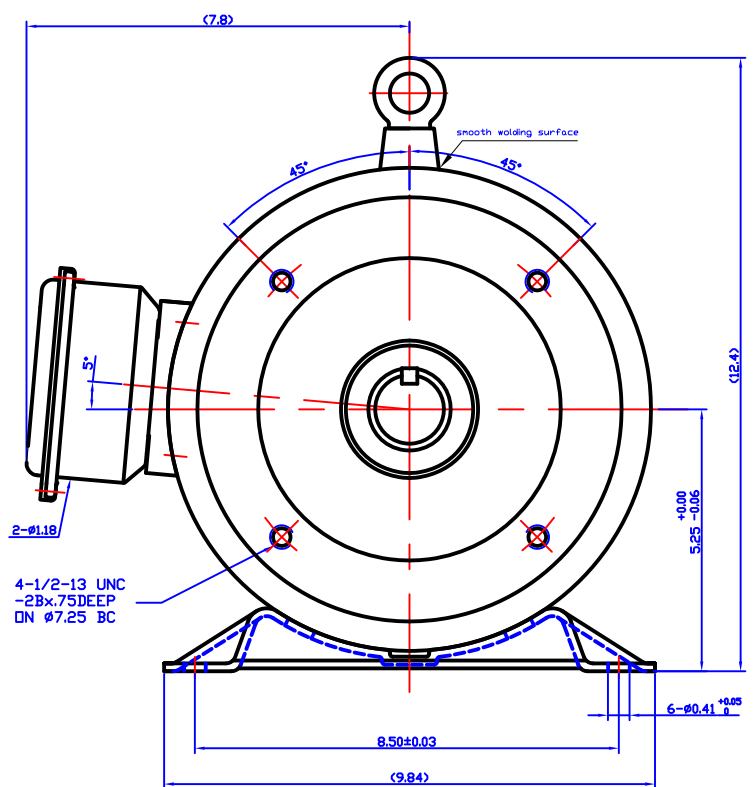

CAT NO.	GW MODEL NO	FRAME	HP	VOLTS	Hz	RPM	MOUNTING	S.F	DUTY	ENCL.	PH
194004.00	GWS7.5-2-213TC	213TC-2	7.5	230/460	60	3600	RIGID+C FLANGE	1.15	CONT.	TEFC	3
194288.00	GWS7.5-2-575-213TC	213TC-2	7.5	575	60	3600	RIGID+C FLANGE	1.15	CONT.	TEFC	3
194005.00	GWS7.5-4-213TC	213TC-4	7.5	230/460	60	1800	RIGID+C FLANGE	1.15	CONT.	TEFC	3
194106.00	GWS7.5-4-575-213TC	213TC-4	7.5	575	60	1800	RIGID+C FLANGE	1.15	CONT.	TEFC	3
194006.00	GWS10-2-215TC	215TC-2	10	230/460	60	3600	RIGID+C FLANGE	1.15	CONT.	TEFC	3
194107.00	GWS10-2-575-215TC	215TC-2	10	575	60	3600	RIGID+C FLANGE	1.15	CONT.	TEFC	3
194007.00	GWS10-4-215TC	215TC-4	10	230/460	60	1800	RIGID+C FLANGE	1.15	CONT.	TEFC	3
194108.00	GWS10-4-575-215TC	215TC-4	10	575	60	1800	RIGID+C FLANGE	1.15	CONT.	TEFC	3

DR BY: ZHAOQING 2016-08-18

APPD:

FIRST ANGLE PROJECTION

EDS DATE VERSION REV5

CONFIDENTIAL: THIS DRAWING AND ITS INFORMATION ARE THE EXCLUSIVE AND CONFIDENTIAL PROPERTY OF REGAL BELOIT CORPORATION AND ARE NOT TO BE DISCLOSED, DUPLICATED, DISTRIBUTED OR OTHERWISE USED WITHOUT THE WRITTEN CONSENT OF REGAL BELOIT CORPORATION

-ALL RIGHTS RESERVED.

**REGAL** REGAL-BELOIT CORPORATION

DESCRIPTION  
OUTLINE OF SST MOTORS FOR 210 FR

SIZE A3 DWG NO **OL210TCSST**

SCALE 1:2 SHEET

005010-01

VIEW FROM OUTSIDE OF MOTOR AT SWITCH END.



VOLTAGE	L1	L2	L3	JOIN & INSULATE
HIGH	T1	T2	T3	(T4,T7) (T5,T8) (T6,T9)
LOW	T1,T7	T2,T8	T3,T9	T4,T5,T6

				TOLERANCES UNLESS SPECIFIED		<b>REGAL</b> ™ <b>Regal Beloit America, Inc.</b>		DRAWN RDW 04/12/02				
				DEC.	INCHES			CHK				
				.X	±.1			APPD				
				.XX	±.01			SCALE 1=1				
				.XXX	±.005	TITLE		REF FIG.2-51				
A	UPDATED TO REGAL LOGO			SAJ	06/26/15	AJY	.XXXX	±.0005	MAT'L. DECAL - 004014	FMF		
NO.	REVISION			BY & DATE	CHK	ANG	±1/2"	FINISH	PREV			
THIS DRAWING IN DESIGN AND DETAIL IS OUR PROPERTY AND MUST NOT BE USED EXCEPT IN CONNECTION WITH OUR WORK ALL RIGHTS OF DESIGN AND INVENTION ARE RESERVED THIS IS AN ELECTRONICALLY GENERATED DOCUMENT - DO NOT SCALE THIS PRINT				RFP	04/12/02		CAD FILE	00501001		SIZE	DRAWING NO.	REV.
				DIST	BRF-NLV				A	005010-01		A

## EC Declaration of Conformity

The undersigned representing  
the manufacturer:

Regal Beloit America  
100 East Randolph St.  
Wausau, WI 54401

and the authorized representative  
established within the Community:

Marathon Electric UK  
6F Thistleton Road Ind. Estate  
Market Overton  
Oakham, Rutland LE15 7PP UK

are committed to providing customers with products that comply with applicable regulations and international protocols to which they are subject, including the requirements of the European Parliament Directive on the Harmonization of the laws relating to electrical equipment designed for use within certain voltage limits (2014/35/EU).

Regal Beloit America declares that the following product(s), to which this declaration relates, are in conformity with the relevant sections of the EC standards listed below.

This statement supersedes any statements previously issued pertaining to the product(s) listed below and is subject to change without notice.

Model No : 194288.00

(Model No. may contain prefix and/or suffix characters)

Catalog No : 194288.00

Rework No : N/A

Directives :

Low Voltage Directive 2014/35/EU

Harmonized Standards Used :

EN 60034-1: 2010 (IEC 60034-1: 2010)

EN 60034-5: 2001/A1:2007 (IEC 60034-5: 2000/A1:2006)

Authorized Representative:



Michael A. Logsdon  
Vice President, Technology

Authorized Representative in the Community:



Julian Clark  
Marketing Engineer

Created on 09/01/2022

**CE 22**