

PRODUCT INFORMATION PACKET



Model No: 193420.60
Catalog No: 193420.60
75 HP General Purpose, 3 phase, 1800 RPM, 230/460 V, 250M Frame, TEFC



Regal and Leeson are trademarks of Regal Rexnord Corporation or one of its affiliated companies.
©2023 Regal Rexnord Corporation, All Rights Reserved. MC017097E





Nameplate Specifications

Phase	3	Output HP	75 & 60 Hp
Output KW	56.0 & 45.0 kW	Voltage	230/460 & 200/400 V
Speed	1785 & 1488 rpm	Service Factor	1.15 & 1.15
Frame	250M	Enclosure	Totally Enclosed Fan Cooled
Thermal Protection	No Protection	Efficiency	95.4 & 95 %
Ambient Temperature	40 °C	Frequency	60 & 50 Hz
Current	174/87 & 164/82 A	Power Factor	84.5
Duty	Continuous	Insulation Class	F
Design Code	B	KVA Code	G
Drive End Bearing Size	6316	Opp Drive End Bearing Size	6313
UL	Recognized	CSA	Y
CE	Y	IP Code	55
Number of Speeds	1		

Technical Specifications

Electrical Type	Squirrel Cage Inverter Rated	Starting Method	Part Wdg Start & Wye Start Delta Run Or Inverter
Poles	4	Rotation	Reversible
Mounting	Rigid Base	Motor Orientation	Horizontal
Drive End Bearing	Ball	Opp Drive End Bearing	Ball
Frame Material	Cast Iron	Shaft Type	IEC
Overall Length	36.29 in	Shaft Diameter	2.555 in
Shaft Extension	5.51 in	Assembly/Box Mounting	F3
Inverter Load	CONSTANT 10:1		
Connection Drawing	00417203	Outline Drawing	SS622318

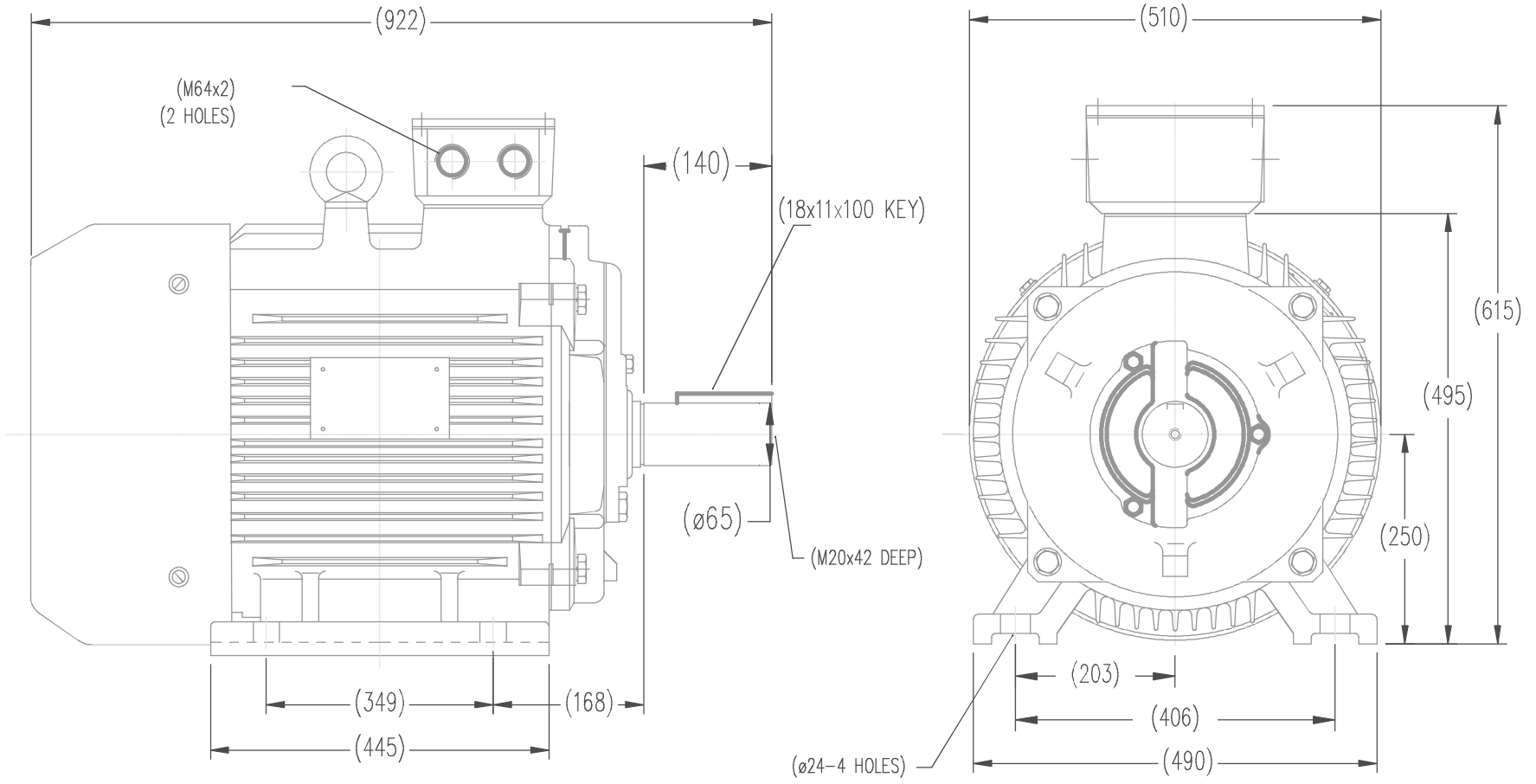

DRAWING NOT TO SCALE

			TOLERANCES UNLESS SPECIFIED		REGAL - BELOIT CORPORATION		DRAWN MOL 06-16-2011				
			DEC.	INCHES			CHK MOL 06-16-2011				
			.X	±2.5	TITLE OUTLINE		SCALE 1=1				
			.XX	±.75			REF 183667.60				
			.XXX	±.127	MATERIAL		PREV				
			.XXXX	±.0127			FINISH				
NO.	REVISION	BY & DATE	CHK	ANG	±1/2	RFP	CAD FILE	SS622318	SIZE	DRAWING NO.	REV.
THIS DRAWING IN DESIGN AND DETAIL IS OUR PROPERTY AND MUST NOT BE USED EXCEPT IN CONNECTION WITH OUR WORK ALL RIGHTS OF DESIGN AND INVENTION ARE RESERVED THIS IS AN ELECTRONICALLY GENERATED DOCUMENT - DO NOT SCALE THIS PRINT						DIST			B	SS622318	

WYE - DELTA STARTING USEABLE ON 2,4 AND 6 POLE MOTORS.

LOW VOLTAGE CONNECTION

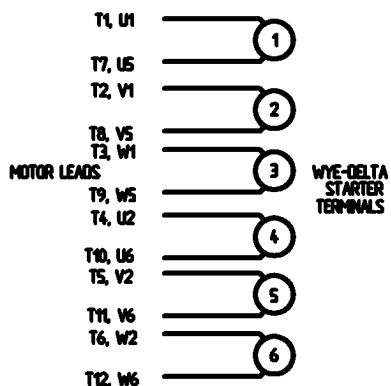

HIGH VOLTAGE CONNECTION

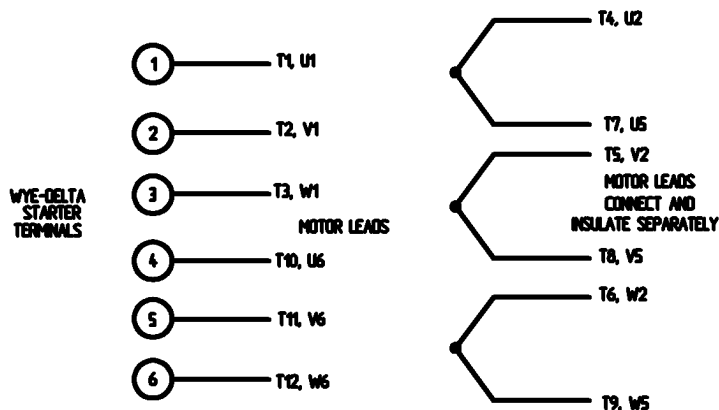

REFER TO THE WYE-DELTA STARTER CONNECTION INSTRUCTIONS FOR PROPER CONNECTION OF POWER LINES TO STARTER.

PART WINDING START USABLE ON 4 & 6 POLE MOTORS
LOW VOLTAGE CONNECTION ONLY

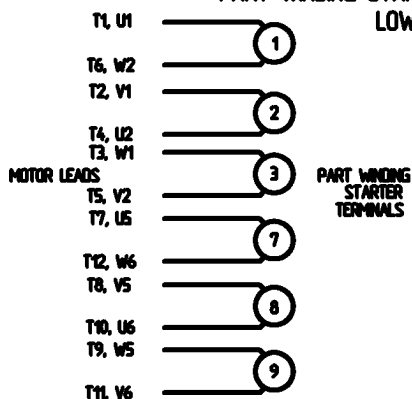

REFER TO THE PART WINDING STARTER INSTRUCTIONS FOR PROPER CONNECTION OF POWER LINES TO STARTER.

REFER TO THE CUTLER - HAMMER OR EQUIV. FOR PROPER SELECTION OF OVERLOAD HEATER COILS.

LINE LEADS

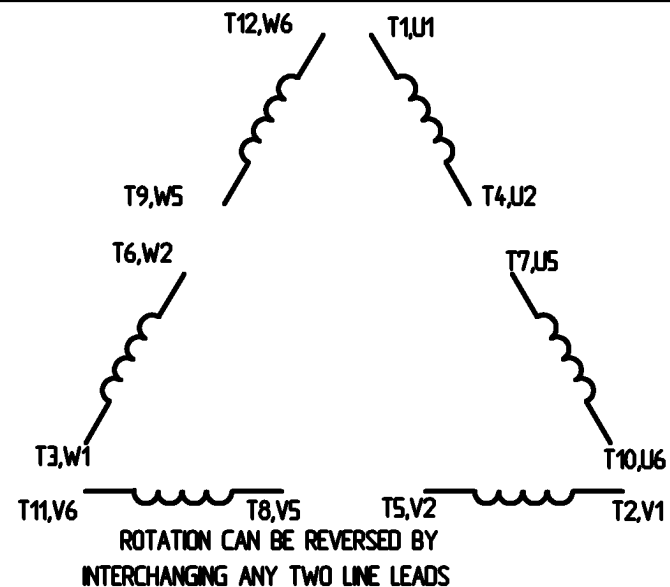

12 LEAD DELTA CONNECTION ACROSS THE LINE START
(FOR Y START DELTA RUN, REMOVE THE JUMPERS)

LOW VOLTAGE
MUST BE REWIRED
AS SHOWN

HIGH VOLTAGE
FACTORY WIRED FOR HIGH
VOLTAGE AS SHOWN

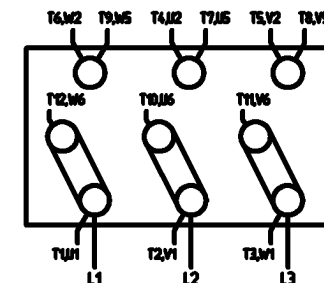
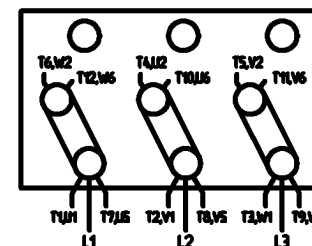

				TOLERANCES UNLESS SPECIFIED			DRAWN CW 08/28/02		
				DEC.	INCHES		CHK		
				X	+ .1		APPO		
				XX	+ .01		SCALE 1:1		
				XXX	+ .005		REF		
				XXXX	+ .0005	FMF			
NO.	REVISION	BY & DATE	CHK	ANG	+ 1/2°	FINISH	PREV		
THIS DRAWING IN DESIGN AND DETAIL IS OUR PROPERTY AND MUST NOT BE USED EXCEPT IN CONNECTION WITH OUR WORK ALL RIGHTS OF DESIGN AND INVENTION ARE RESERVED THIS IS AN ELECTRONICALLY GENERATED DOCUMENT - DO NOT SCALE THIS PRINT				RFP	CAD FILE	00417203	SIZE A	DRAWING NO. 004172-03	REV.
				DST					

ERROR: syntaxerror
OFFENDING COMMAND: --nostringval--

STACK:

/CB
-dictionary-
/Pscript_WinNT_Compat
-dictionary-



1051 CHEYENNE AVE.
GRAFTON, WI 53024
PH. 262-277-8810

DATA VOLTS: 460

CERTIFICATION DATA SHEET

CONN. DIAGRAM: 00417203
OUTLINE: SS622318
WINDING: T19604019

CAT #: 193420.60

NONE 3

TYPICAL MOTOR PERFORMANCE DATA

HP	KW	SYNC RPM	FL RPM	FRAME	ENCLOSURE	TYPE	KVA CODE	DESIGN
75	56	1800	1785	250M	TEFC	TFC	G	B

PH	HZ	VOLTS	AMPS	START TYPE	DUTY	INSL	S.F.	AMB	ELEV.
3	60/50	230/460#200/400	174/87&164/82	PWS & YDRUN OR INV	CONT	F	1.15	40	3300

F.L. EFF	95.4	3/4 LD EFF	95.4	1/2 LD EFF	95.0	GTD EFF	ELECT. TYPE
F.L. PF	84.5	3/4 LD PF	81.5	1/2 LD PF	74.5	95.0	SQ CAGE INV RATED

F.L. TORQUE	LR AMPS @ 460 V	L.R. TORQUE	B.D. TORQUE	F.L. RISE (° C)
221 LB-FT	542	440 LB-FT 199%	575 LB-FT 260%	45

PRESSURE @ 3	SOUND	POWER	ROTOR WK²	MAX. LOAD WK²	SAFE STALL TIME	STARTS/HOUR	MOTOR WGT
75 dBA	84 dBA		25.0 LB-FT²	0 LB-FT²	20 SEC.	2	1250 LB.

***** SUPPLEMENTAL INFORMATION *****

DE BRACKET TYPE	ODE BRACKET TYPE	MOUNT TYPE	MOTOR ORIENTATION	SEVERE DUTY	HAZARDOUS LOCATION	DRIP COVER	SCREENS	PAINT
STANDARD	STANDARD	RIGID	HORIZONTAL	UM SEVERE	NONE	NO	NONE	WATTSAVER

BEARINGS		GREASE	SHAFT TYPE	SPECIAL DE	SPECIAL ODE	SHAFT MATERIAL	FRAME MATERIAL
DE	ODE	POLYREX EM	STANDARD IEC	NONE	NONE	1045 HOT ROLLED (C-204)	CAST IRON
BALL	BALL						
6316	6313						

THERMOSTATS	PROTECTORS	WDG RTD's	BRG RTD's	THERMISTORS	CONTROL	SPACE HEATERS
NONE	NOT	NONE	NONE	NONE	FALSE	NA

R1 (ohms/ph)	R2 (ohms/ph)	X1 (ohms/ph)	X2 (ohms/ph)	Xm (ohms/ph)	VIBRATION (in/sec)	FLOAT
0	0	0	0	0	0.080	ODE

* N O T E S *	INVERTER TORQUE: CONSTANT 10:1 INV. HP SPEED RANGE: 1.5 X BASE SPEED					
	ENCODER: NONE NONE NONE					
	BRAKE: NONE NONE NONE					
	FT-LB: NA VOLTAGE: NONE					
	HZ: NONE PPR					

DATE:	8/29/2018	UL: Y-(LEESON UL REC)
-------	-----------	-----------------------

Data Sheet

Date: 8/29/2018

193420.60



Data @ **460 V**

Motor Load Data

Load	0%	25%	50%	75%	100%	115%	125%	LR
Current (Amps)	27.0	34.5	49.5	67.5	87.0	100	110	542
Torque (ft-lb)	0.00	55.0	110	165	221	254	277	440
RPM	1800	1795	1792	1788	1785	1,782	1780	0
Efficiency (%)		92.4	95.0	95.4	95.4	95.4	95.0	
P.F. (%)	4.5	54.5	74.5	81.5	84.5	85.0	85.0	30.0

Motor Speed Data

	LR	Pull-Up	BD	Rated	Idle
Speed (RPM)	0	900	1730	1785	1800
Current (Amps)	542	475	325	87.0	27.0
Torque (ft-lb)	440	400	575	221	0.00

Information Block				
HP	75.0			
Sync. RPM	1800			
Frame	365			
Enclosure	TEFC			
Construction	TFC			
Voltage	230/460#200/400 V			
Frequency	60 Hz			
Design	A			
LR Code letter	G			
Service Factor	1.15			
Temp Rise @ FL	45 ° C			
Duty	CONT			
Ambient	40 ° C			
Elevation	1,000 feet			
Rotor/Shaft wk ²	25.0 Lb-Ft ²			
Ref Wdg	T19604019 NONE			
Sound Pressure @ 1M	75 dBA			
VFD Rating	CONSTANT 10:1			
Outline Dwg	SS622318			
Conn. Diag	00417203			
Additional Specifications:				
0				
0				
EQUIV CKT (OHMS / PHASE)				
R1	R2	X1	X2	Xm
0.0000	0.0000	0.0000	0.0000	0.0000

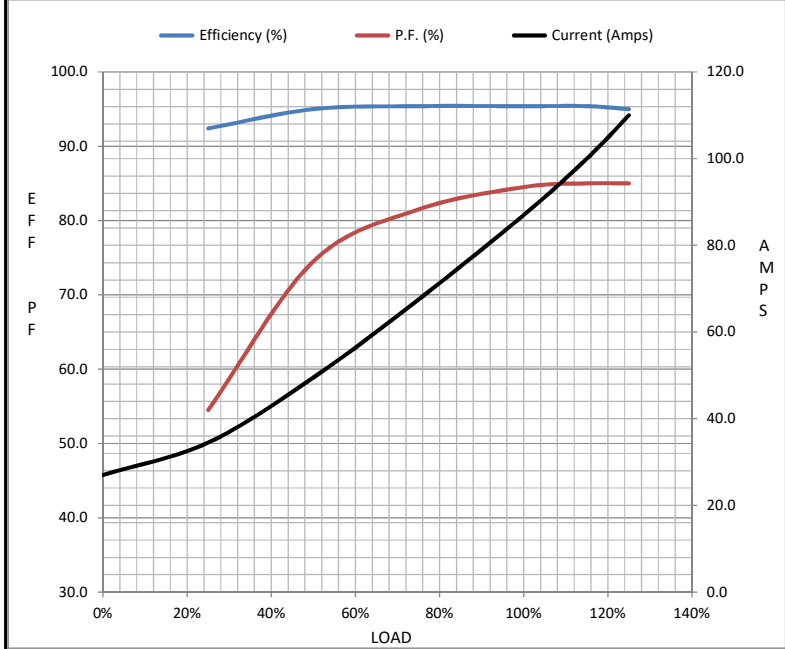

Speed - Torque Curve

