

# PRODUCT INFORMATION PACKET



Model No: 193343.60

Catalog No: 193343.60

LEESON® PASSPORT 7.5 HP General Purpose, 3 phase, 1800 RPM, 230/460 V, 132S Frame, TEFC



Regal and Leeson are trademarks of Regal Rexnord Corporation or one of its affiliated companies.

©2023 Regal Rexnord Corporation, All Rights Reserved. MC017097E





### Nameplate Specifications

Phase	3	Output HP	7.50 & 5.50 Hp
Output KW	5.6 & 4.1 kW	Voltage	230/460 & 190/380 V
Speed	1770 & 1475 rpm	Service Factor	1.15 & 1.15
Frame	132S	Enclosure	Totally Enclosed Fan Cooled
Thermal Protection	No Protection	Efficiency	92.4 & 92.4 %
Ambient Temperature	40 °C	Frequency	60 & 50 Hz
Current	18.4/9.2 & 17/8.5 A	Power Factor	82.5
Duty	Continuous	Insulation Class	F
Design Code	B	KVA Code	J
Drive End Bearing Size	6308	Opp Drive End Bearing Size	6306
UL	Recognized	CSA	Y
CE	Y	IP Code	55
Number of Speeds	1		

### Technical Specifications

Electrical Type	Squirrel Cage Inverter Rated	Starting Method	Wye Start Delta Run Or Inverter
Poles	4	Rotation	Reversible
Resistance Main	.399 Ohms	Mounting	Rigid Base
Motor Orientation	Horizontal	Drive End Bearing	Ball
Opp Drive End Bearing	Ball	Frame Material	Cast Iron
Shaft Type	IEC	Overall Length	18.26 in
Shaft Diameter	1.500 in	Shaft Extension	3.15 in
Assembly/Box Mounting	F3		
Outline Drawing	B-SS622263	Connection Drawing	004172.01

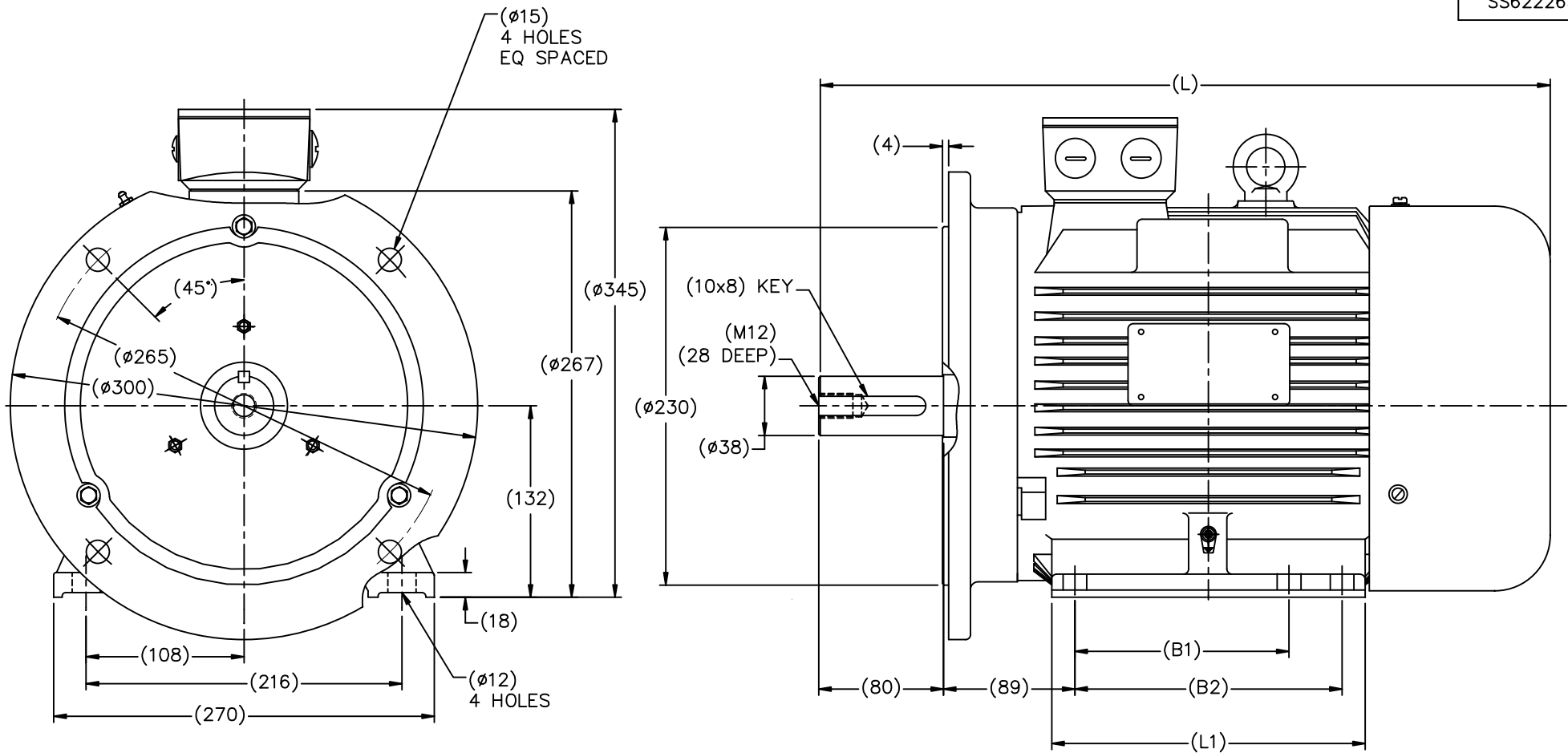

FRAME	CAT.NO	B1	B2	L1	L	n
DF132SD1-2R	193342.60	140	/	186	464	4
DF132SD1-4R	193343.60	140	/	186	464	4
DF132SMD-2R	193345.60	140	178	224	502	6
DF132SMD-4R	193346.60	140	178	224	502	6
DF132MD1-6R	193341.60	178	/	224	502	4
DF132MD2-6R	193344.60	178	/	224	502	4

(MAY NOT BE DRAWN TO SCALE)

(DIMENSIONS ARE IN MILLIMETERS)

NO.		REVISION	BY & DATE	CHK	ANG	FINISH	TOLERANCES UNLESS SPECIFIED			DRAWN HLB 12-07-2010					
							DEC.	METRIC		CHK	DJK 12-17-2010				
							.X	±2.5			APPD	SB 12-18-2010			
							.XX	±.76			SCALE	1=18			
							.XXX	±.127			REF				
							.XXXX	±.0127		FMF	HEBEI				
THIS DRAWING IN DESIGN AND DETAIL IS OUR PROPERTY AND MUST NOT BE USED EXCEPT IN CONNECTION WITH OUR WORK ALL RIGHTS OF DESIGN AND INVENTION ARE RESERVED THIS IS AN ELECTRONICALLY GENERATED DOCUMENT - DO NOT SCALE THIS PRINT							RFP	12-22-2010	CAD FILE	SS622263	SIZE	DRAWING NO.	PAGE	OF	REV.
							DIST				B	SS622263			

WYE - DELTA STARTING USEABLE ON 2,4 AND 6 POLE MOTORS.

LOW VOLTAGE CONNECTION

HIGH VOLTAGE CONNECTION

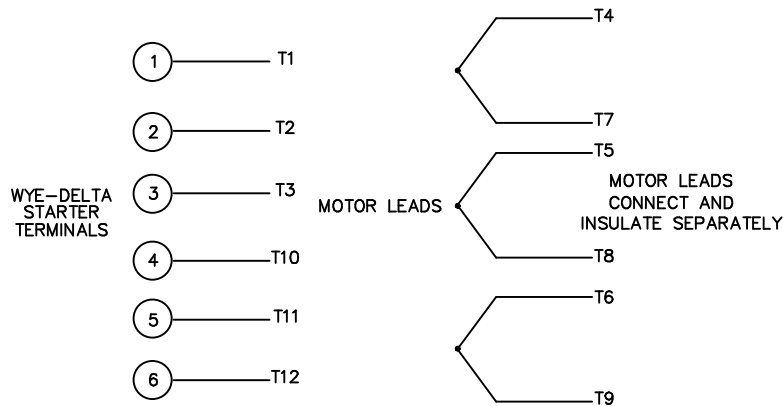
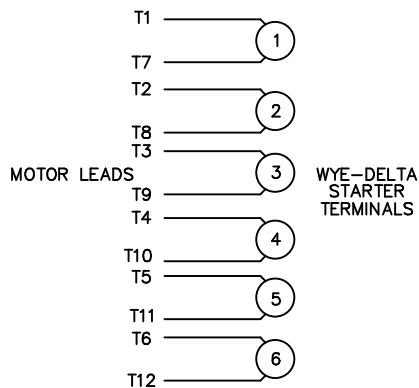

REFER TO THE WYE-DELTA STARTER CONNECTION INSTRUCTIONS FOR PROPER CONNECTION OF POWER LINES TO STARTER.

PART WINDING START USABLE ON 4 & 6 POLE MOTORS  
LOW VOLTAGE CONNECTION ONLY

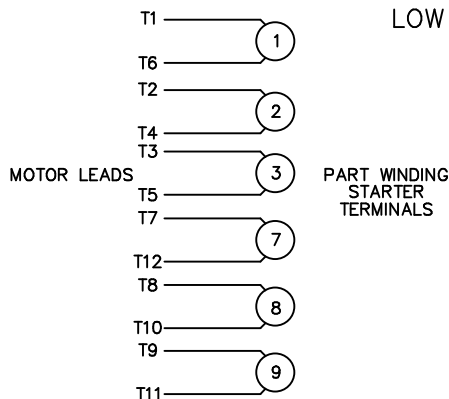

REFER TO THE PART WINDING STARTER INSTRUCTIONS FOR PROPER CONNECTION OF POWER LINES TO STARTER.

REFER TO THE CUTLER - HAMMER OR EQUIV. FOR PROPER SELECTION OF OVERLOAD HEATER COILS.

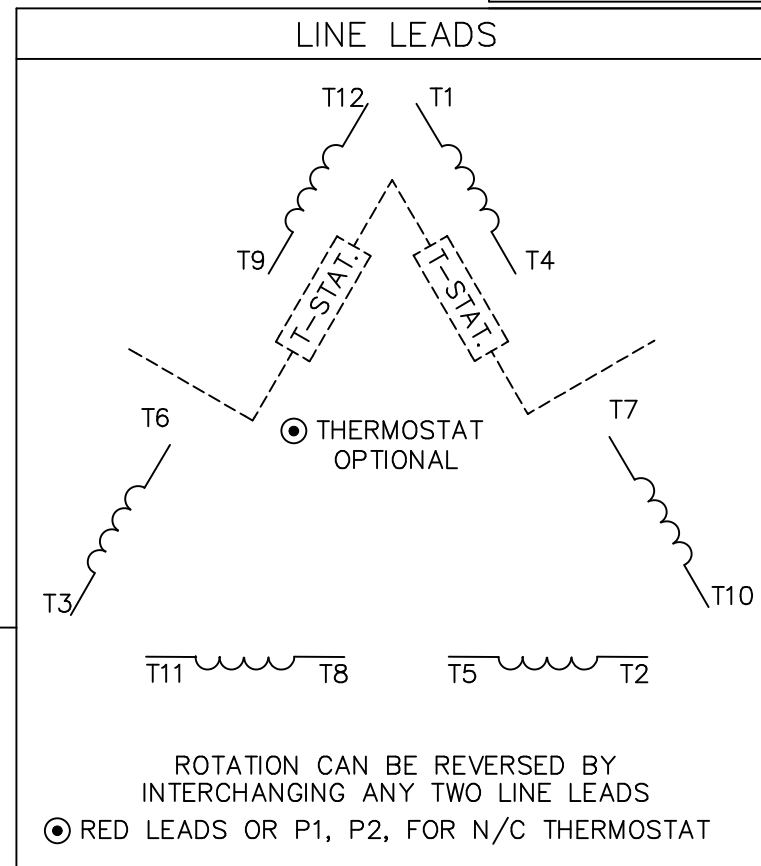

ACROSS THE LINE START & RUN				
	LINE 1	LINE 2	LINE 3	JOIN & INSULATE SEPARATELY
HIGH VOLT	T1, T12	T2, T10	T3, T11	(T4, T7) (T5, T8) (T6, T9)
LOW VOLT	T1, T6 T7, T12	T2, T4 T8, T10	T3, T5 T9, T11	

				TOLERANCES UNLESS SPECIFIED		ELECTRIC MOTORS GEARMOTORS AND DRIVES	DRAWN WLW 09/08/77		
				DEC.	INCHES		CHK RPB 09/12/77		
				.X	±.1		APPD JCW 09/12/77		
03	REV'D LOW VOLTAGE CONN. LEADS PER ELEC.	BJB 06/07/00	.XX	±.01	TITLE	DELTA - WYE CONNECTION DIAGRAM	SCALE	1=1	
02	ADDED T-STAT. NOTES PER ELECTRICAL	KMM 06/02/98	.XXX	±.005			REF		
01	REDRAWN TO CAD	DBT 06/02/97	.XXXX	±.0005	MAT'L.		FMF		
NO.	REVISION	BY & DATE	CHK	ANG	±1/2"	FINISH	PREV		
THIS DRAWING IN DESIGN AND DETAIL IS OUR PROPERTY AND MUST NOT BE USED EXCEPT IN CONNECTION WITH OUR WORK ALL RIGHTS OF DESIGN AND INVENTION ARE RESERVED THIS IS AN ELECTRONICALLY GENERATED DOCUMENT - DO NOT SCALE THIS PRINT				RFP	CAD FILE	00417201	SIZE	DRAWING NO.	REV.
				DIST			A	004172-01	03



**CERTIFICATION DATA SHEET**

**1051 CHEYENNE AVE.  
GRAFTON, WI 53024  
PH. 262-377-8810**

**CATALOG #:** 193343.60

**CONN. DIAGRAM:** 004172.01

**OUTLINE:** B-SS622263

**MOUNTING:** F3

**WINDING #:** T10704028 3

**TYPICAL MOTOR PERFORMANCE DATA**

HP	kW	SYNC. RPM	F.L. RPM	FRAME	ENCLOSURE	KVA CODE	DESIGN
7 1/2&5 1/2	5.60&4.10	1800	1770&1475	132S	TEFC	J	B

PH	Hz	VOLTS	AMPS	START TYPE	DUTY	INSL	S.F.	AMB°C
3	60/50	230/460&190/380	18.4/9.2&17/8.5	Y START D RUN OR INV	CONTINUOUS	F5	1.15/1.15	40

FULL LOAD EFF:	92.4&92.4	3/4 LOAD EFF:	92.4	1/2 LOAD EFF:	91	GTD. EFF		ELEC. TYPE	
FULL LOAD PF:	82.5&82.5	3/4 LOAD PF:	77.5	1/2 LOAD PF:	66.5	91		SQ CAGE INV RATED	

F.L. TORQUE	LOCKED ROTOR AMPS	L.R. TORQUE	B.D. TORQUE	F.L. RISE°C
22.2 LB-FT	143 / 71.5	47 LB-FT 210 %	80 LB-FT 360 %	32

SOUND PRESSURE @ 3 FT.	SOUND POWER	ROTOR WK^2	MAX. WK^2	SAFE STALL TIME	STARTS / HOUR	APPROX. MOTOR WGT
47 dBA	57 dBA	- LB-FT^2	- LB-FT^2	20 SEC.	2	140 LBS.

**\*\*\* SUPPLEMENTAL INFORMATION \*\*\***

DE BRACKET TYPE	ODE BRACKET TYPE	MOUNT TYPE	ORIENTATION	SEVERE DUTY	HAZARDOUS LOCATION	DRIP COVER	SCREENS	PAINT
FF-FLANGE-265	STANDARD	RIGID	HORIZONTAL	PREMIUM SEVERE DUTY	NONE	FALSE	NONE	BLUE - LEESON (ENAMEL)

BEARINGS		GREASE	SHAFT TYPE	SPECIAL DE	SPECIAL ODE	SHAFT MATERIAL	FRAME MATERIAL
DE	ODE						
BALL	BALL	POLYREX EM	STANDARD IEC	NONE	NONE	AISI 1045 (C-240)	CAST IRON
6308	6306						

THERMO-PROTECTORS				THERMISTORS	CONTROL	SPACE HEATERS
THERMOSTATS	PROTECTORS	WDG RTDs	BRG RTDs			
NONE	NOT	NONE	NONE	NONE	FALSE	NONE VOLTS

\*  
N  
O  
T  
E

<b>INVERTER TORQUE:</b> CONSTANT 10:1
<b>INV. HP SPEED RANGE:</b> NONE
<b>ENCODER:</b> NONE
NONE NONE
NONE NONE PPR
<b>BRAKE:</b> NONE NONE
NONE P/N NONE
NONE NONE
NONE FT-LB NONE V NO BRAKE Hz

Data Sheet

Date: 1/19/2018

193343.60



Data @ 460 V

Motor Load Data

Load	0%	25%	50%	75%	100%	115%	125%	LR
Current (Amps)	4.2	4.6	5.8	7.5	9.2	10.2	11.2	71.5
Torque (ft-lb)	0.00	5.5	11.0	16.8	22.2	25.5	27.8	47.0
RPM	1800	1795	1788	1778	1770	1.765	1760	0
Efficiency (%)		86.5	91.0	92.4	92.4	92.4	91.7	
P.F. (%)	5.5	44.0	66.5	77.5	82.5	84.0	85.0	40.0

Motor Speed Data

	LR	Pull-Up	BD	Rated	Idle
Speed (RPM)	0	900	1585	1770	1800
Current (Amps)	71.5	65.0	42.5	9.2	4.2
Torque (ft-lb)	47.0	40.0	80.0	22.2	0.00

Information Block				
HP	7.5			
Sync. RPM	1800			
Frame	132			
Enclosure	TEFC			
Construction	TFC			
Voltage	230/460#190/380 V			
Frequency	60 Hz			
Design	A			
LR Code letter	J			
Service Factor	1.15			
Temp Rise @ FL	30 °C			
Duty	CONT			
Ambient	40 °C			
Elevation	1,000 feet			
Rotor/Shaft wk <sup>2</sup>	0.00 Lb-Ft <sup>2</sup>			
Ref Wdg	T10704028 NONE			
Sound Pressure @ 1M	47 dBA			
VFD Rating	CONSTANT 10:1			
Outline Dwg	B-SS622263			
Conn. Diag	004172.01			
Additional Specifications:				
0				
0				
EQUIV CKT (OHMS / PHASE)				
R1	R2	X1	X2	Xm
0.0000	0.0000	0.0000	0.0000	0.0000

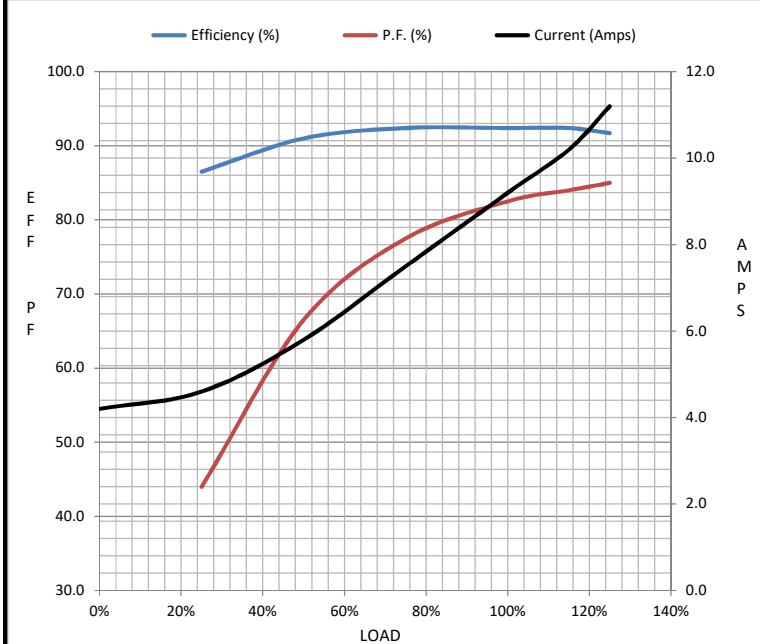

Speed - Torque Curve

