

PRODUCT INFORMATION PACKET



Model No: 193313.60

Catalog No: 193313.60

LEESON® PASSPORT 10 HP General Purpose, 3 phase, 1800 RPM, 230/460 V, 132M Frame, TEFC



Regal and Leeson are trademarks of Regal Rexnord Corporation or one of its affiliated companies.

©2023 Regal Rexnord Corporation, All Rights Reserved. MC017097E





Nameplate Specifications

Phase	3	Output HP	10 & 7.50 Hp
Output KW	7.5 & 5.6 kW	Voltage	230/460 & 200/400 V
Speed	1765 & 1475 rpm	Service Factor	1.15 & 1.15
Frame	132M	Enclosure	Totally Enclosed Fan Cooled
Thermal Protection	No Protection	Efficiency	91.7 & 91.7 %
Ambient Temperature	40 °C	Frequency	60 & 50 Hz
Current	24/12 & 21.6/10.8 A	Power Factor	86
Duty	Continuous	Insulation Class	F
Design Code	B	KVA Code	J
Drive End Bearing Size	6308	Opp Drive End Bearing Size	6207
UL	Recognized	CSA	Y
CE	Y	IP Code	55
Number of Speeds	1		

Technical Specifications

Electrical Type	Squirrel Cage Inverter Rated	Starting Method	Wye Start Delta Run Or Inverter
Poles	4	Rotation	Reversible
Resistance Main	.8 Ohms	Mounting	Rigid Base
Motor Orientation	Horizontal	Drive End Bearing	Ball
Opp Drive End Bearing	Ball	Frame Material	Cast Iron
Shaft Type	IEC	Overall Length	19.76 in
Shaft Diameter	1.500 in	Shaft Extension	3.15 in
Assembly/Box Mounting	F3	Inverter Load	CONSTANT 10:1
Connection Drawing	004172.03	Outline Drawing	B-SS622237

SS622237

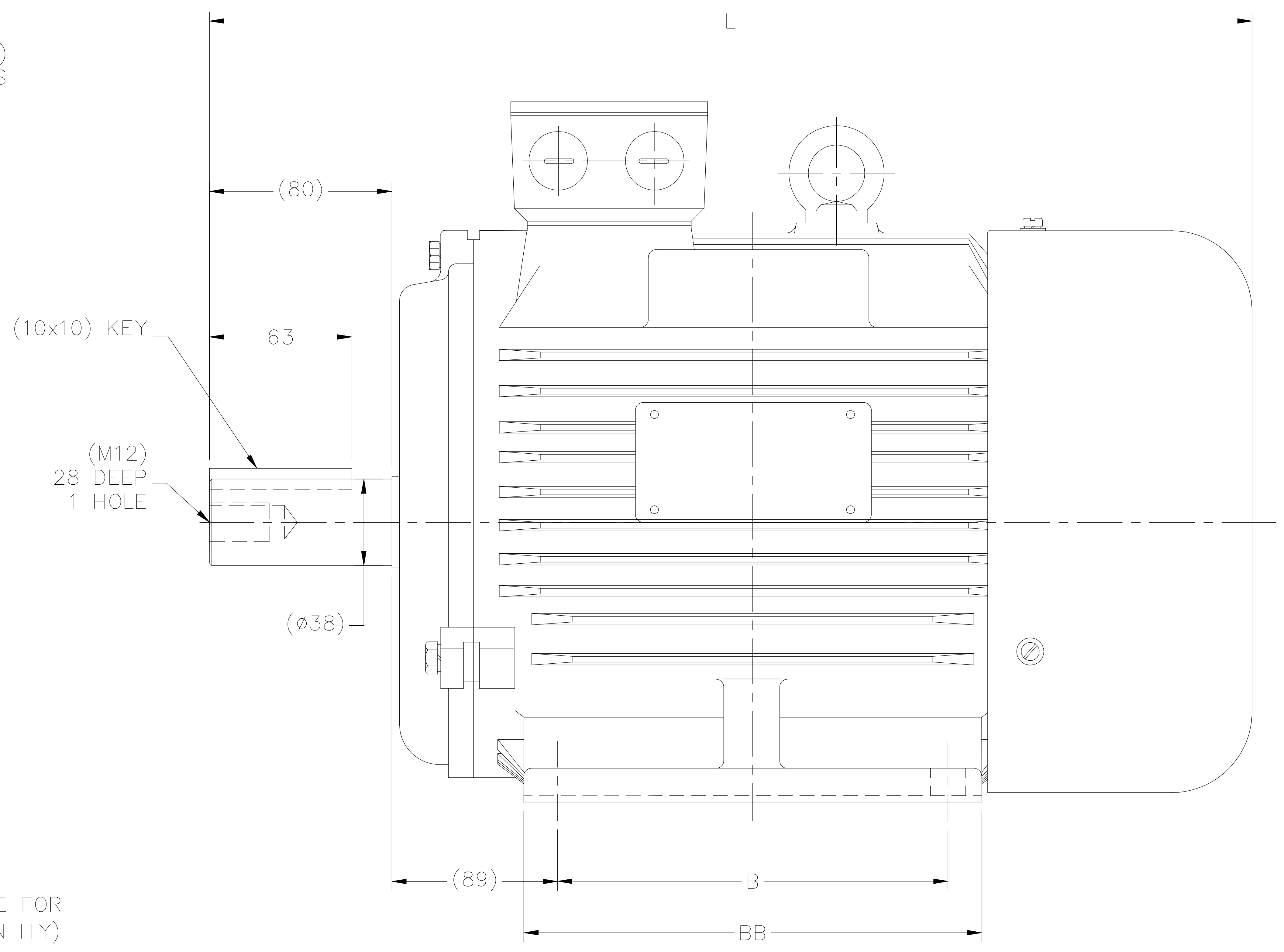
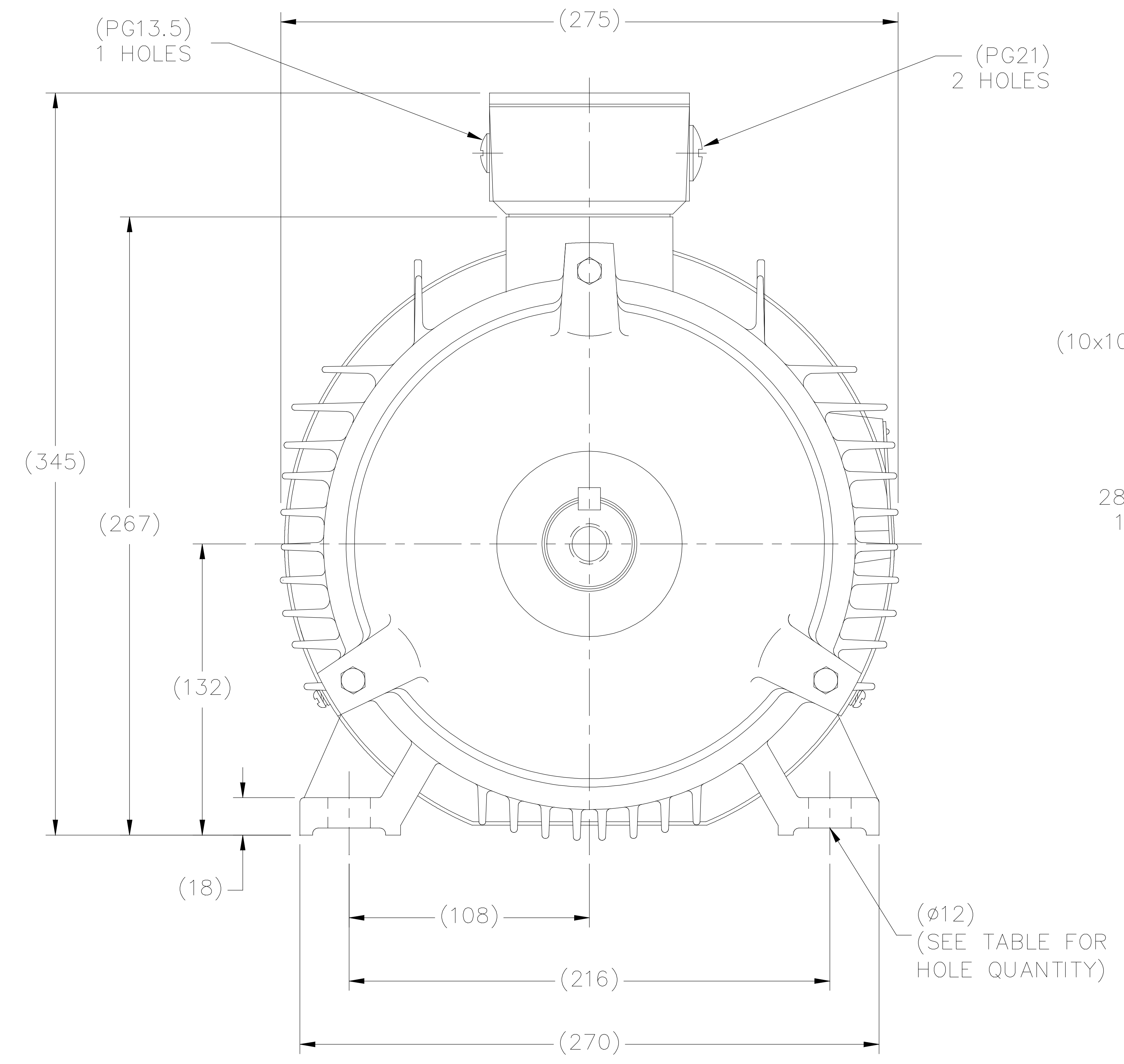

(DRAWING NOT TO SCALE)

(DIMENSIONS ARE IN MILLIMETERS)

DF132S	4	461	140	186
DF132M	4	499	178	224
FRAME	# HOLES	L	B	BB

NO.	REVISION	BY & DATE	CHK	ANG	TOLERANCES UNLESS SPECIFIED		FINISH	DRAWN MSG 11-16-2010				
					DEC.	METRIC						
4	TABLE AND DIMENSIONS UPDATED	NK 07-05-18	NK	.X	±2.5			CHK MJS 11-18-2010				
3	(4) FOOT HOLES WERE (6) ECO-0130304	WGJ 10-2-17	EMH	.XX	±.76			APPD SB 11-18-2010				
2	REM CAT# FROM BLOCK-FOR CAT# SEE SS622237-CAT	MOL 11-29-12		.XXX	±.127		TITLE OUTLINE - IEC PREMIUM DF132-R FRAME	SCALE NONE				
1	REV PG13.5 HOLES WERE 2 QTY	MOL 09-24-12		.XXXX	±.0127		MAT'L.	REF				
					±7'30"			FMF HEBEI				
								PREV				
THIS DRAWING IN DESIGN AND DETAIL IS OUR PROPERTY AND MUST NOT BE USED EXCEPT IN CONNECTION WITH OUR WORK ALL RIGHTS OF DESIGN AND INVENTION ARE RESERVED THIS IS AN ELECTRONICALLY GENERATED DOCUMENT - DO NOT SCALE THIS PRINT							RFP 11-18-2010	CAD FILE SS622237	SIZE B	DRAWING NO. SS622237	PAGE OF	REV. H



WYE - DELTA STARTING USEABLE ON 2,4 AND 6 POLE MOTORS.

LOW VOLTAGE CONNECTION

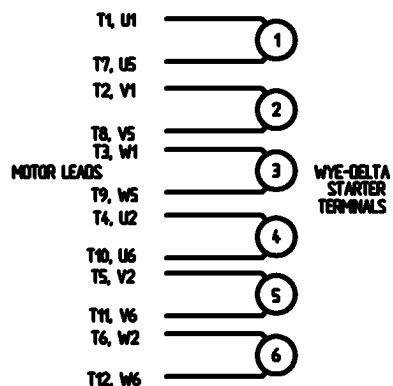

HIGH VOLTAGE CONNECTION

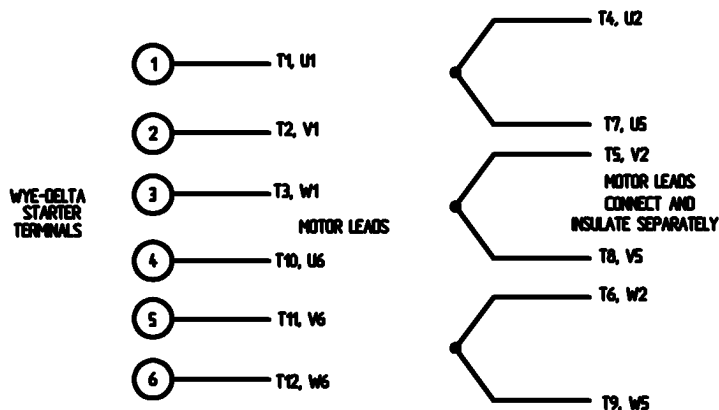

REFER TO THE WYE-DELTA STARTER CONNECTION INSTRUCTIONS FOR PROPER CONNECTION OF POWER LINES TO STARTER.

PART WINDING START USABLE ON 4 & 6 POLE MOTORS
LOW VOLTAGE CONNECTION ONLY

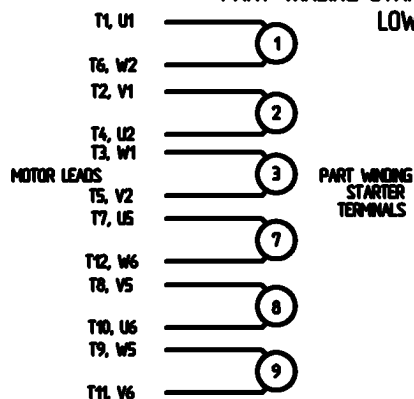

REFER TO THE PART WINDING STARTER INSTRUCTIONS FOR PROPER CONNECTION OF POWER LINES TO STARTER.

REFER TO THE CUTLER - HAMMER OR EQUIV. FOR PROPER SELECTION OF OVERLOAD HEATER COILS.

LINE LEADS

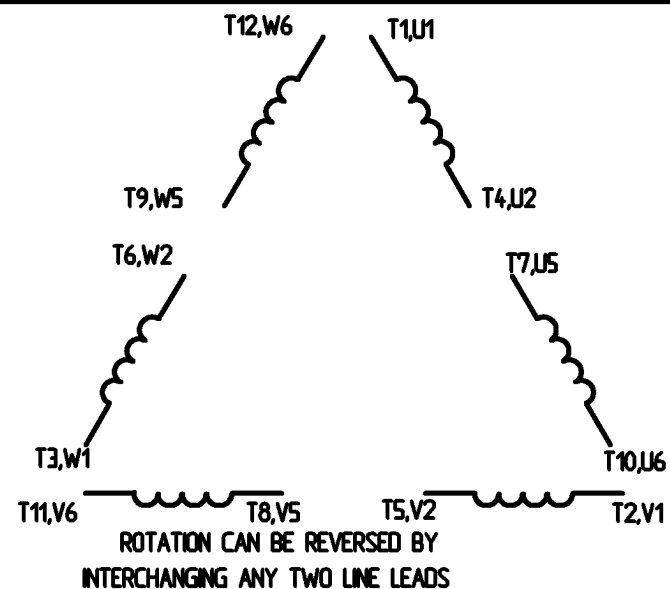

12 LEAD DELTA CONNECTION ACROSS THE LINE START
(FOR Y START DELTA RUN, REMOVE THE JUMPERS)

LOW VOLTAGE
MUST BE REWIRED
AS SHOWN

HIGH VOLTAGE
FACTORY WIRED FOR HIGH
VOLTAGE AS SHOWN

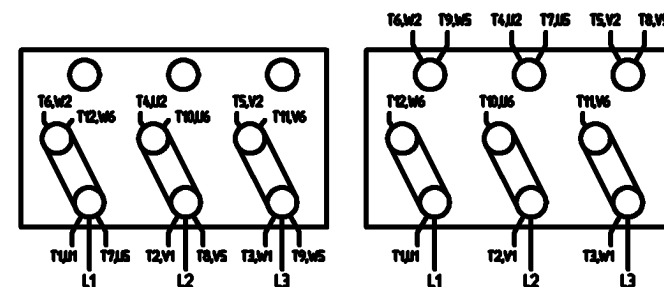

				TOLERANCES UNLESS SPECIFIED		 ELECTRIC MOTORS GEARMOTORS AND DRIVES	DRAWN CW 08/28/02 CHK APPD SCALE 1:1 REF FMF PREV
				DEC.	INCHES		TITLE DELTA - WYE CONNECTION DIAGRAM IEC CAST IRON MOTORS
				X	+ .1		
				XX	+ .01		
				XXX	+ .005		
				XXXX	+ .0005	MAT'L	
NO.	REVISION	BY & DATE	CHK	ANG	+ 1/2°	FINISH	PREV
THIS DRAWING IN DESIGN AND DETAIL IS OUR PROPERTY AND MUST NOT BE USED EXCEPT IN CONNECTION WITH OUR WORK. ALL RIGHTS OF DESIGN AND INVENTION ARE RESERVED. THIS IS AN ELECTRONICALLY GENERATED DOCUMENT - DO NOT SCALE THIS PRINT.				RFP	CAD FILE	00417203	SIZE A
				DST			DRAWING NO. 004172-03
							REV.

ERROR: syntaxerror
OFFENDING COMMAND: --nostringval--

STACK:

/CB
-dictionary-
/Pscript_WinNT_Compat
-dictionary-

Data Sheet

Date: 2/1/2018

193313.60



Data @ 460 V

Motor Load Data

Load	0%	25%	50%	75%	100%	115%	125%	LR
Current (Amps)	4.8	5.5	7.2	9.5	12.0	13.6	14.8	89.5
Torque (ft-lb)	0.00	7.3	14.7	22.2	29.8	34.3	37.4	59.0
RPM	1800	1790	1785	1775	1765	1760	1755	0
Efficiency (%)		87.5	91.7	92.4	91.7	91.7	91.0	
P.F. (%)	6.0	48.5	71.0	80.5	85.0	86.0	86.5	40.0

Motor Speed Data

	LR	Pull-Up	BD	Rated	Idle
Speed (RPM)	0	750	1575	1765	1800
Current (Amps)	89.5	83.0	54.3	12.0	4.8
Torque (ft-lb)	59.0	57.0	96.5	29.8	0.00

Information Block				
HP	10.0			
Sync. RPM	1800			
Frame	132			
Enclosure	TEFC			
Construction	TFC			
Voltage	230/460#200/400 V			
Frequency	60 Hz			
Design	A			
LR Code letter	J			
Service Factor	1.15			
Temp Rise @ FL	37 °C			
Duty	CONT			
Ambient	40 °C			
Elevation	1,000 feet			
Rotor/Shaft wk ²	0.00 Lb-Ft ²			
Ref Wdg	T10704027 NONE			
Sound Pressure @ 1M	46 dBA			
VFD Rating	CONSTANT 10:1			
Outline Dwg	B-SS622237			
Conn. Diag	004172.03			
Additional Specifications:				
0				
0				
EQUIV CKT (OHMS / PHASE)				
R1	R2	X1	X2	Xm
0.0000	0.0000	0.0000	0.0000	0.0000

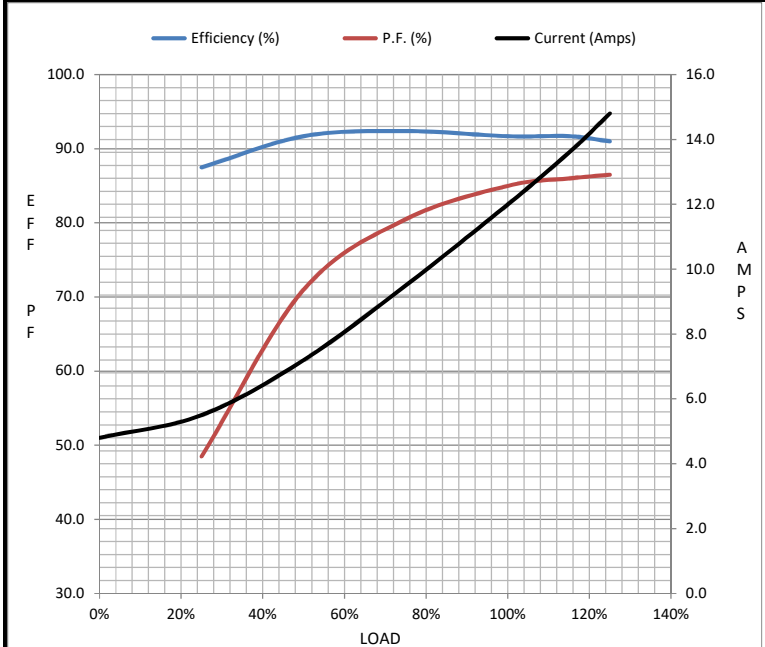

Speed - Torque Curve

