

PRODUCT INFORMATION PACKET



Model No: 193162.60

Catalog No: 193162.60

30HP..1180/985RPM.200L.IP55.230/460V.3PH.60/50HZ.CONT.NOT.40C.1.15/1.15SF.B3.IEC Metric.C200T11FZ2C

Regal and Leeson are trademarks of Regal Rexnord Corporation or one of its affiliated companies.

©2023 Regal Rexnord Corporation, All Rights Reserved. MC017097E





Nameplate Specifications

Phase	3	Output HP	30 & 30 Hp
Output KW	22.4 & 22.4 kW	Voltage	230/460 & 200/400 V
Speed	1180 & 985 rpm	Service Factor	1.15 & 1.15
Frame	DF200L	Enclosure	IP55
Thermal Protection	No Protection	Efficiency	91.7 %
Ambient Temperature	40 °C	Frequency	60 & 50 Hz
Current	76.0/38.0 & 87.4/43.7 A	Power Factor	80.6
Duty	Continuous	Insulation Class	F
Design Code	B	KVA Code	H
Drive End Bearing Size	6312	Opp Drive End Bearing Size	6312
UL	Recognized	CSA	Y
CE	Y	IP Code	55
Number of Speeds	1		

Technical Specifications

Electrical Type	Squirrel Cage Induction Run	Starting Method	Across The Line
Poles	6	Rotation	Reversible
Resistance Main	.263 Ohms	Mounting	B3
Motor Orientation	Nan	Drive End Bearing	Ball
Opp Drive End Bearing	Ball	Frame Material	Cast Iron
Shaft Type	IEC	Assembly/Box Mounting	NAN
Outline Drawing	16989660	Connection Drawing	004172.03

This is an uncontrolled document once printed or downloaded and is subject to change without notice. Date Created:06/23/2023

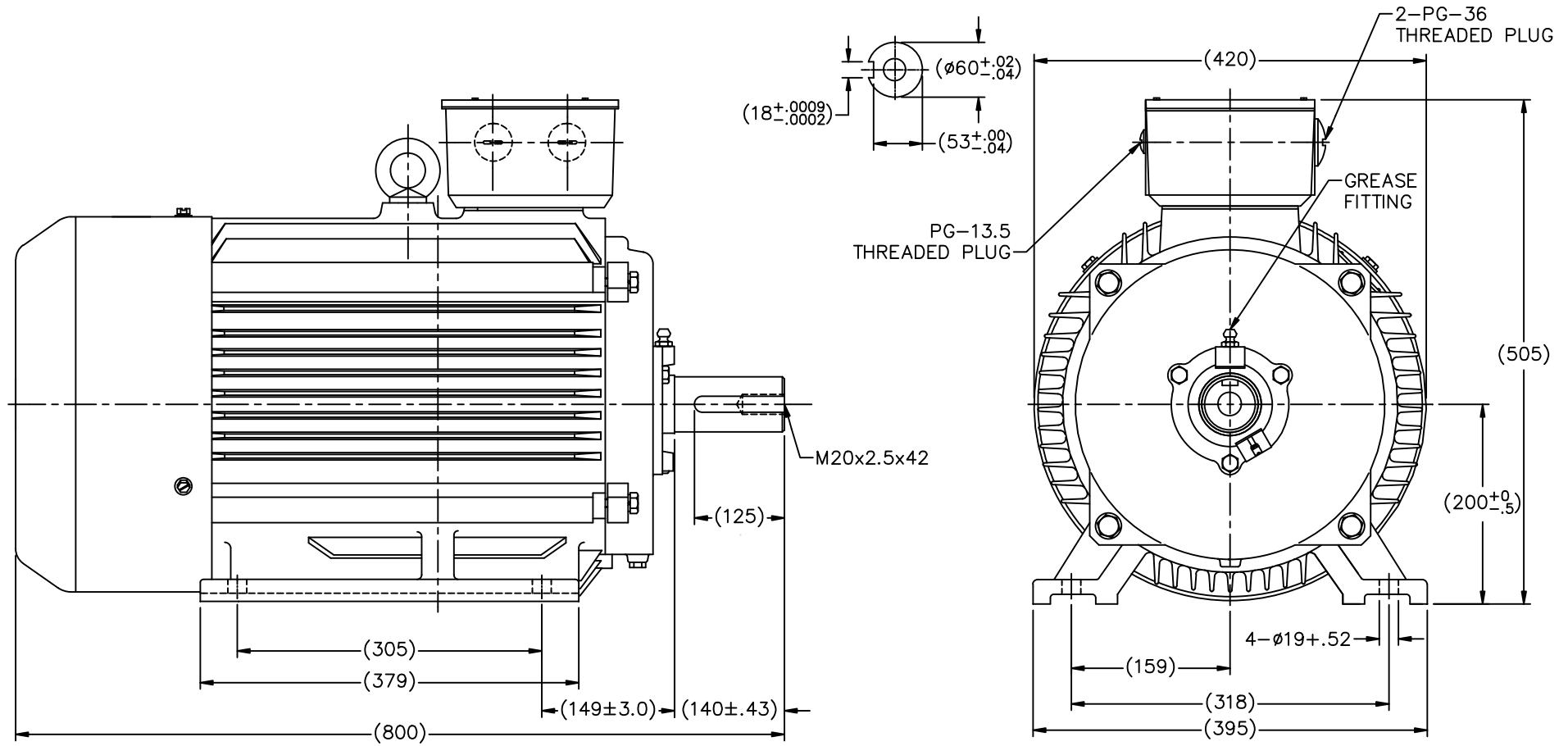

			TOLERANCES UNLESS SPECIFIED			ELECTRIC MOTORS GEARMOTORS AND DRIVES	DRAWN CTO 02-05-2003	
			DEC.	METRIC			CHK	
			.X	±2.5			APPD SB 02-05-2003	
2	CHANGED DIM.	ISAAC 10-2790	.XXX	±.76	TITLE OUTLINE		SCALE 1=4	
1	NEW DRAWING	CTO	.XXXX	±.0127	DF200L-F3 - IEC		REF	
NO.	REVISION	BY & DATE	CHK	ANG ±7'30"	MAT'L		FMF	
THIS DRAWING IN DESIGN AND DETAIL IS OUR PROPERTY AND MUST NOT BE USED EXCEPT IN CONNECTION WITH OUR WORK ALL RIGHTS OF DESIGN AND INVENTION ARE RESERVED THIS IS AN ELECTRONICALLY GENERATED DOCUMENT - DO NOT SCALE THIS PRINT			RFP		FINISH		PREV	
			DIST	WA-PR	CAD FILE 16989660	SIZE B	DRAWING NO. 169896-60	PAGE OF 2
							REV. 2	

WYE - DELTA STARTING USEABLE ON 2,4 AND 6 POLE MOTORS.

LOW VOLTAGE CONNECTION

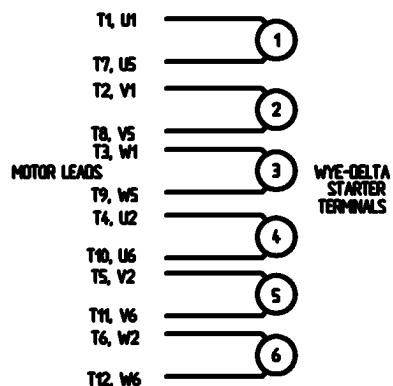

HIGH VOLTAGE CONNECTION



REFER TO THE WYE-DELTA STARTER CONNECTION INSTRUCTIONS FOR PROPER CONNECTION OF POWER LINES TO STARTER.

PART WINDING START USABLE ON 4 & 6 POLE MOTORS
LOW VOLTAGE CONNECTION ONLY

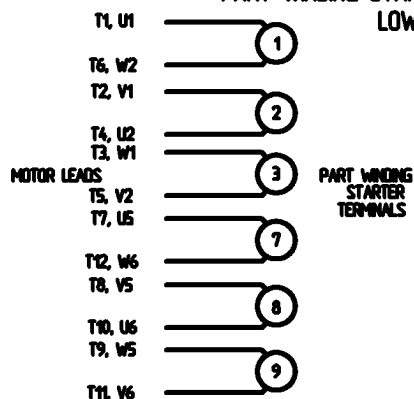

REFER TO THE PART WINDING STARTER INSTRUCTIONS FOR PROPER CONNECTION OF POWER LINES TO STARTER.

REFER TO THE CUTLER - HAMMER OR EQUIV. FOR PROPER SELECTION OF OVERLOAD HEATER COILS.

LINE LEADS

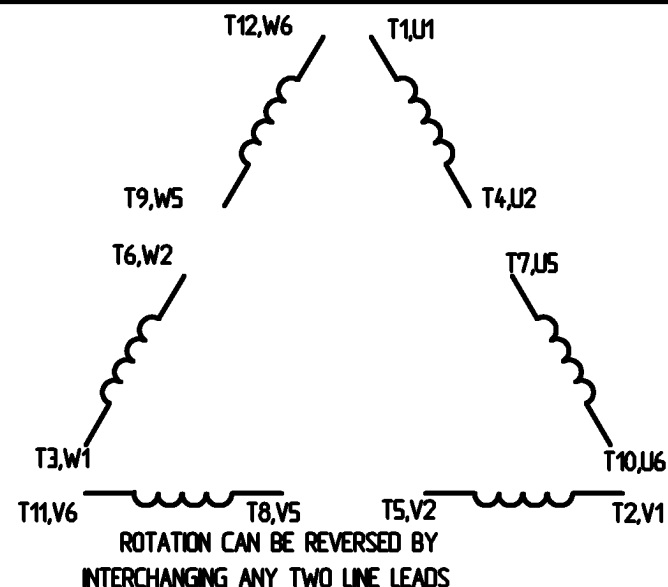

12 LEAD DELTA CONNECTION ACROSS THE LINE START
(FOR Y START DELTA RUN, REMOVE THE JUMPERS)

LOW VOLTAGE
MUST BE REWIRED
AS SHOWN

HIGH VOLTAGE
FACTORY WIRED FOR HIGH
VOLTAGE AS SHOWN

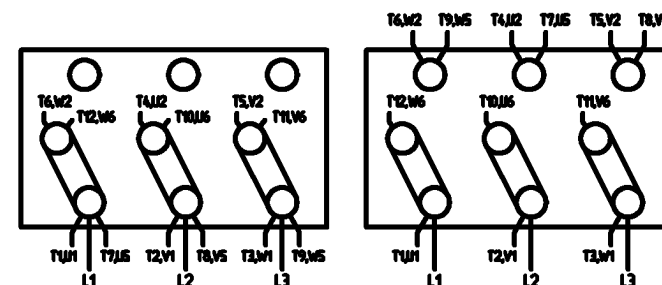

				TOLERANCES UNLESS SPECIFIED		LEESON ELECTRIC MOTORS GEARMOTORS AND DRIVES	DRAWN	CJW 08/28/02	
				DEC.	INCHES		CHK		
				X	+ .1	TITLE	SCALE	1:1	
				XX	+ .01	DELTA - WYE CONNECTION DIAGRAM IEC CAST IRON MOTORS	REF		
				XXX	+ .005		PMF		
				XXXX	+ .0005	MAT'L	PREV		
NO.	REVISION	BY & DATE	CHK	ANG	+ 1/2°	FINISH			
THIS DRAWING IN DESIGN AND DETAIL IS OUR PROPERTY AND MUST NOT BE USED EXCEPT IN CONNECTION WITH OUR WORK. ALL RIGHTS OF DESIGN AND INVENTION ARE RESERVED. THIS IS AN ELECTRONICALLY GENERATED DOCUMENT - DO NOT SCALE THIS PRINT.				RFP	CAD FILE	00417203	SIZE	DRAWING NO.	REV.
				DST			A	004172-03	

ERROR: syntaxerror
OFFENDING COMMAND: --nostringval--

STACK:

/CB
-dictionary-
/Pscript_WinNT_Compat
-dictionary-