

PRODUCT INFORMATION PACKET

Model No: 184TTTN16545

Catalog No: U1868

XRI®-SD Severe Duty Motor, 5 & 3 HP, 3 Ph, 60 & 50 Hz, 230/460 & 190/380 V, 1800 & 1500 RPM,
184TV Frame, TEAO



Regal and Marathon are trademarks of Regal Rexnord Corporation or one of its affiliated companies.
©2023 Regal Rexnord Corporation, All Rights Reserved. MC017097E

Nameplate Specifications

Phase	3	Output HP	5 & 3 Hp
Output KW	3.7 & 2.2 kW	Voltage	230/460 & 190/380 V
Speed	1755 & 1487 rpm	Service Factor	1.15 & 1.15
Frame	184TV	Enclosure	Totally Enclosed Air Over
Thermal Protection	No Protection	Efficiency	90.2 & 89.7 %
Ambient Temperature	40 °C	Frequency	60 & 50 Hz
Current	12.4/6.2 & 9.4/4.7 A	Power Factor	83.5
Duty	Continuous	Insulation Class	F
Design Code	B	KVA Code	J
Drive End Bearing Size	6206	Opp Drive End Bearing Size	6206
UL	Recognized	CSA	Y
CE	N	IP Code	56
Number of Speeds	1		

Technical Specifications

Electrical Type	Squirrel Cage Inverter Rated	Starting Method	Line Or Inverter
Poles	4	Rotation	Reversible
Resistance Main	2.62 Ohms	Mounting	Rigid Base
Motor Orientation	Horizontal Or Up Or Down	Drive End Bearing	Ball
Opp Drive End Bearing	Ball	Frame Material	Cast Iron
Shaft Type	T	Overall Length	15.74 in
Frame Length	10.00 in	Shaft Diameter	1.125 in
Shaft Extension	2.85 in	Assembly/Box Mounting	F1/F2 CAPABLE
Inverter Load	CONSTANT 20:1		
Outline Drawing	035670-1000	Connection Drawing	A-EE7308

This is an uncontrolled document once printed or downloaded and is subject to change without notice. Date Created:10/19/2023

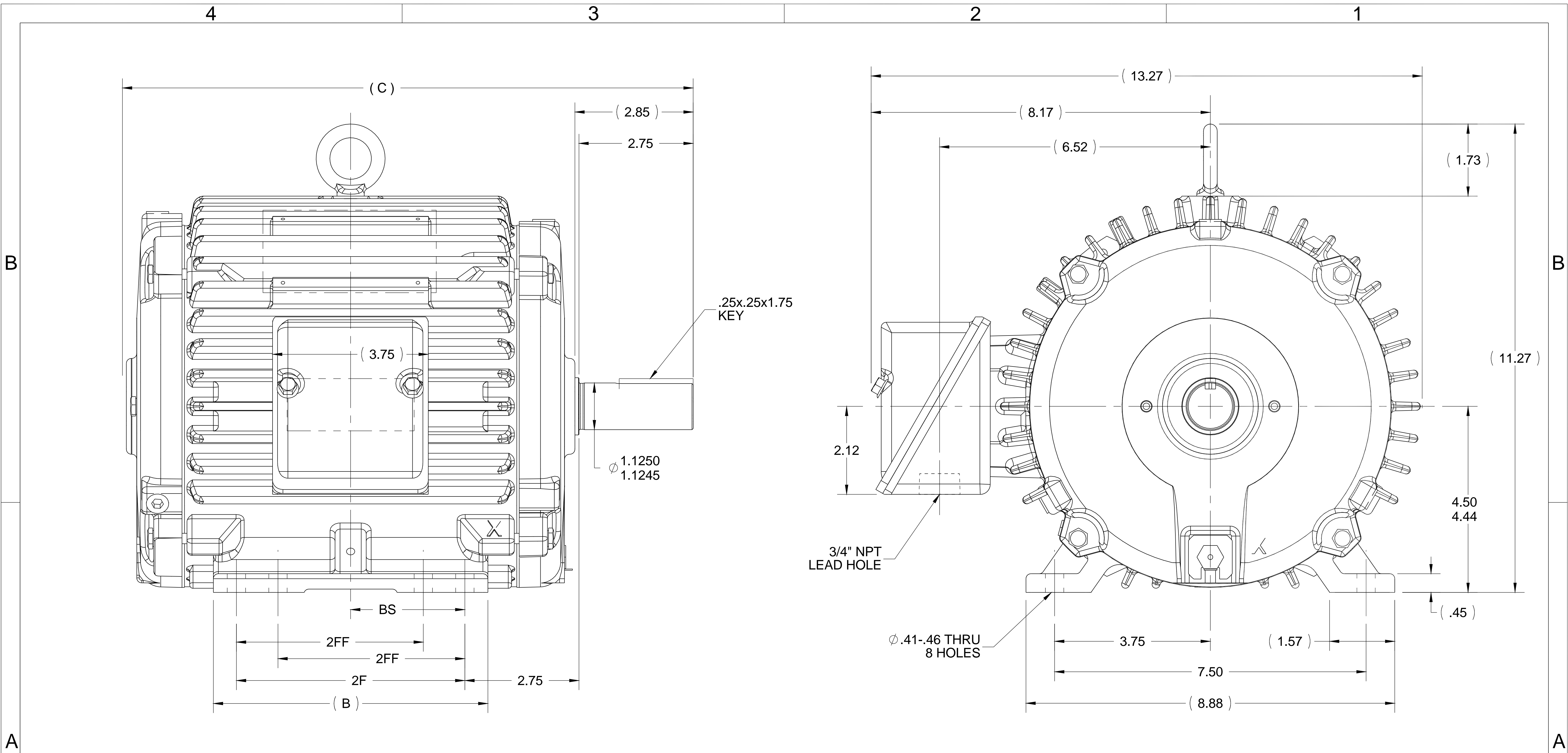

- NOTES:
 1. NAMEPLATE TO BE READ FROM CONDUIT BOX SIDE OF MOTOR.
 2. CONDUIT BOX CAN ROTATED IN 90° STEPS.
 3. CONDUIT BOX CAN BE MOUNTED ON OPPOSITE SIDE BY REMOVING BRACKETS AND TURNING FRAME 180°

DRAWING REVISION C	REVISION BY SS	DATE 05/31/16
ECO ECO-0101042	APPROVED BY GR	DATE 05/31/16
ECO DESCRIPTION TEMPLATE UPDATED.		
<small>COPYRIGHT REGAL BELOIT AMERICA, INC. ALL RIGHTS RESERVED. PROPRIETARY AND CONFIDENTIAL INFORMATION - THIS DOCUMENT IS THE PROPERTY OF REGAL BELOIT AMERICA, INC. ("OWNER") AND CONTAINS OWNER'S PROPRIETARY INFORMATION. ANY PERSON, CORPORATION OR OTHER FIRM RECEIVING IT IS DEEMED, BY RECEIVING IT, TO AGREE THAT IT, AND/OR ANY PART OF IT, SHALL NOT BE DISCLOSED TO ANY PERSON, CORPORATION OR OTHER ENTITY, DUPLICATED, AND/OR USED, EXCEPT AS EXPRESSLY APPROVED IN WRITING IN ADVANCE BY OWNER. THIS DOCUMENT SHALL BE RETURNED TO OWNER UPON REQUEST. IT MAY BE SUBJECT TO CERTAIN RESTRICTIONS UNDER APPLICABLE EXPORT CONTROL LAWS AND REGULATIONS.</small>		

TOLERANCES UNLESS OTHERWISE SPECIFIED:

DEC.	INCH	mm	ANGLE
.X	±0.1	[±2.5]	±0.5°
.XX	±0.01	[±0.25]	
.XXX	±0.005	[±0.127]	
.XXXX	±0.0005	[±0.0127]	

REMOVE BURRS & BREAK SHARP EDGES: .003/.015 [.076/.381] X 45°
 CORNER FILLETS: R.02 [.51]
 MACHINED SURFACES: 125 INCH 3.2 mm

DRAWN BY TJW
DATE 3/25/2008
APPROVED BY SW
DATE 3/26/2008
REFERENCE
THIRD ANGLE PROJECTION

REGAL ™ Regal Beloit America, Inc.	
DESCRIPTION	OUTLINE 180 FR. - CAST C'BOX
MATERIAL	PROCESS/FINISH
SIZE B	DRAWING NUMBER 035670
	SHEET 1 OF 1

1000	182/184	15.74	8.61	7.50	5.50	3.75
800	182/184	13.74	6.61	5.50	4.50	2.75
DASH	FRAME	C	B	2F	2FF	BS



NO.	REVISION	BY & DATE	CHK	ANG	TOLERANCES UNLESS SPECIFIED		FINISH	DRAWN RM 11/20/1990				
					DEC.	INCHES						
5	CHG TO REGAL LOGO	SL 09/10/2015	AB					CHK ML 11/21/1990				
4	REVISED IEC NOTATIONS	MSG 11/15/2011	CMN	.X	±.1			APPD SAS 04/24/2003				
3	ADDED IEC NOTATIONS... (U1), (V1) ETC. MU95194	MSG 5/10/2010	MJS	.XX	±.02		TITLE CONNECTION DIAGRAM	SCALE 1=1				
2	ADDED THE OPTIONAL CORD CONNECTION MU46318	RDH 04/24/2003	DRS	.XXX	±.005		3Ø - DUAL VOLTAGE MOTOR	REF				
1	REDRAWN	RM 11/20/1990		.XXXX	±.0005		MAT'L.	FMF				
					±7'30"			PREV				
THIS DRAWING IN DESIGN AND DETAIL IS OUR PROPERTY AND MUST NOT BE USED EXCEPT IN CONNECTION WITH OUR WORK ALL RIGHTS OF DESIGN AND INVENTION ARE RESERVED THIS IS AN ELECTRONICALLY GENERATED DOCUMENT - DO NOT SCALE THIS PRINT							RFP	CAD FILE ee7308	SIZE A	DRAWING NO. EE7308	PAGE OF 5	REV. 5
							DIST WP					

CERTIFICATION DATA SHEET

Model#: 184TTTN16545 AA **WINDING#:** K1844215 R15 1
CONN. DIAGRAM: A-EE7308 **ASSEMBLY:** F1/F2 CAPABLE
OUTLINE: 035670-1000

TYPICAL MOTOR PERFORMANCE DATA

HP	KW	SYNC. RPM	F.L. RPM	FRAME	ENCLOSURE	KVA CODE	DESIGN
5&3	3.70&2.24	1800	1755&1487	184TV	TEAO	J	B

PH	Hz	VOLTS	FL AMPS	START TYPE	DUTY	INSL	S.F	AMB°C	ELEVATION
3	60/50	230/460#190/ 380	12.4/6.2&9.4/4 .7	LINE OR INVERTER	CONTINUOU S	F3	1.15/1.15	40	3300

FULL LOAD EFF: 90.2&89.7	3/4 LOAD EFF: 90.2	1/2 LOAD EFF: 90.2	GTD. EFF	ELEC. TYPE	NO LOAD AMPS
FULL LOAD PF: 83.5&89.3	3/4 LOAD PF: 78.5	1/2 LOAD PF: 70	89.5	SQ CAGE INV RATED	5.6 / 2.8

F.L. TORQUE	LOCKED ROTOR AMPS	L.R. TORQUE	B.D. TORQUE	F.L. RISE°C
15 LB-FT	92 / 46	34.5 LB-FT 230	45 LB-FT 300	0

SOUND PRESSURE @ 3 FT.	SOUND POWER	ROTOR WK^2	MAX. WK^2	SAFE STALL TIME	STARTS /HOUR	APPROX. MOTOR WGT
62 dBA	72 dBA	0.5 LB-FT^2	50 LB-FT^2	25 SEC.	2	135 LBS.

***** SUPPLEMENTAL INFORMATION *****

DE BRACKET TYPE	ODE BRACKET TYPE	MOUNT TYPE	ORIENTATION	SEVERE DUTY	HAZARDOUS LOCATION	DRIP COVER	SCREENS	PAINT
STANDARD	STANDARD	RIGID	HORIZONTAL OR UP OR DOWN	PREMIUM SEVERE DUTY	NONE	FALSE	NONE	BLUE (EPOXY)

BEARINGS		GREASE	SHAFT TYPE	SPECIAL DE	SPECIAL ODE	SHAFT MATERIAL	FRAME MATERIAL
DE	OPE						
BALL	BALL	POLYREX EM	T	NONE	NONE	1144 STRESSPROOF (C-223)	CAST IRON
6206	6206						

THERMO-PROTECTORS				THERMISTORS	CONTROL	SPACE /n HEATERS
THERMOSTATS	PROTECTORS	WDG RTDs	BRG RTDs			
NONE	NOT	NONE	NONE	NONE	FALSE	NONE VOLTS

If Inverter equals NONE, contact factory for further information

INVERTER TORQUE: CONSTANT 20:1
INV. HP SPEED RANGE: NONE
ENCODER: NONE
NONE NONE
NONE NONE PPR
BRAKE: NONE NONE
NONE P/N NONE
NONE NONE
NONE FT-LB NONE V NONE Hz

*
N
O
T
E
S
*

** Subject to change without notice.

Data Sheet

Date: 6/20/2017

Customer: _____

Attention: _____

Submitted by: FAREEDA DUDEKULA



184TTTN16545

Submittal

Data @ 460 V

Motor Load Data

Load	0%	25%	50%	75%	100%	115%	125%	LR
Current (Amps)	2.80	3.0	3.8	5.0	6.2	7.2	7.8	46.0
Torque (ft-lb)	0.00	3.7	7.4	11.5	15.0	17.5	19.0	34.5
RPM	1800	1790	1780	1765	1755	1,745	1740	0
Efficiency (%)		85.5	90.2	90.2	90.2	89.5	88.5	
P.F. (%)	6.5	47.0	70.0	78.5	83.5	84.5	86.0	48.0

Motor Speed Data

	LR	Pull-Up	BD	Rated	Idle
Speed (RPM)	0	900	1600	1755	1800
Current (Amps)	46.0	41.0	25.0	6.2	2.80
Torque (ft-lb)	34.5	31.0	45.0	15.0	0.00

Information Block

HP	5.0			
Sync. RPM	1800			
Frame	184			
Enclosure	TEAO			
Construction	TTS			
Voltage	30/460#190/381V			
Frequency	60 Hz			
Design	B			
LR Code letter	J			
Service Factor	1.15			
Temp Rise @ FL	0 °C			
Duty	CONT			
Ambient	40 °C			
Elevation	1,000 feet			
Rotor/Shaft wk ²	0.50 Lb-Ft ²			
Ref Wdg	K1844215 R15			
Sound Pressure @ 1M	62 dBA			
VFD Rating	CONSTANT 20:1			
Outline Dwg	035670-1000			
Conn. Diag	A-EE7308			
Additional Specifications:				
0				
0				
EQUIV CKT (OHMS / PHASE)				
R1	R2	X1	X2	Xm
1.5080	1.1280	3.6910	5.6930	104.3280

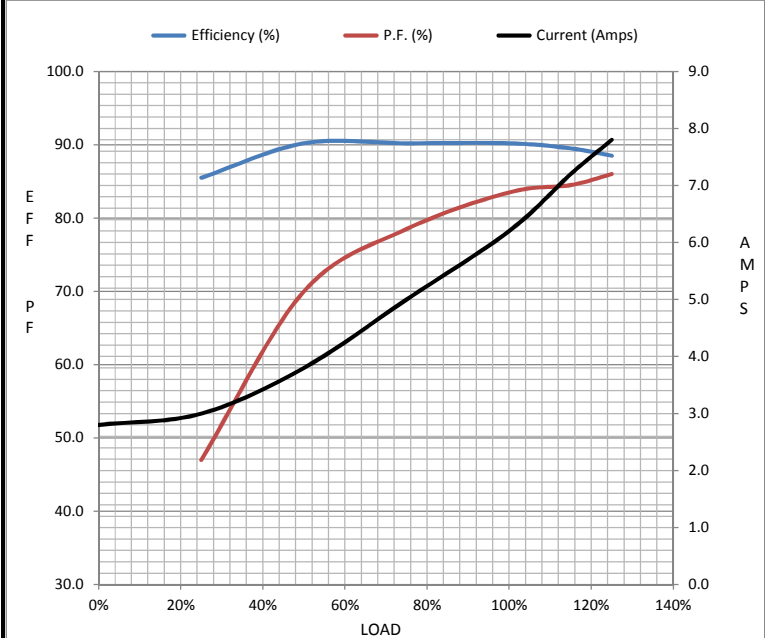

Speed -Torque Curve

