

# PRODUCT INFORMATION PACKET

Model No: 184TTFS6001

Catalog No: E217

5 HP General Purpose Motor, 3 phase, 3600 RPM, 230/460 V, 184T Frame, TEFC  
General Purpose Motors



Regal and Marathon are trademarks of Regal Rexnord Corporation or one of its affiliated companies.

©2021 Regal Rexnord Corporation, All Rights Reserved. MC017097E



### Nameplate Specifications

Output HP	<b>5 Hp</b>	Output KW	<b>3.7 kW</b>
Frequency	<b>60 Hz</b>	Voltage	<b>230/460 V</b>
Current	<b>11.8/5.9 A</b>	Speed	<b>3505 rpm</b>
Service Factor	<b>1.15</b>	Phase	<b>3</b>
Efficiency	<b>88.5 %</b>	Power Factor	<b>88.5</b>
Duty	<b>Continuous</b>	Insulation Class	<b>F</b>
Design Code	<b>B</b>	KVA Code	<b>J</b>
Frame	<b>184T</b>	Enclosure	<b>Totally Enclosed Fan Cooled</b>
Thermal Protection	<b>No</b>	Ambient Temperature	<b>40 °C</b>
Drive End Bearing Size	<b>6206</b>	Opp Drive End Bearing Size	<b>6205</b>
UL	<b>Recognized</b>	CSA	<b>Y</b>
CE	<b>Y</b>	IP Code	<b>43</b>
Number of Speeds	<b>1</b>		

### Technical Specifications

Electrical Type	<b>Squirrel Cage Induction Run</b>	Starting Method	<b>Across The Line</b>
Poles	<b>2</b>	Rotation	<b>Reversible</b>
Resistance Main	<b>2.32 Ohms</b>	Mounting	<b>Rigid Base</b>
Motor Orientation	<b>Horizontal</b>	Drive End Bearing	<b>Ball</b>
Opp Drive End Bearing	<b>Ball</b>	Frame Material	<b>Cast Iron</b>
Shaft Type	<b>T</b>	Overall Length	<b>15.81 in</b>
Frame Length	<b>6.75 in</b>	Shaft Diameter	<b>1.125 in</b>
Shaft Extension	<b>2.78 in</b>	Assembly/Box Mounting	<b>F1/F2 Capable</b>
Connection Drawing	<b>A-EE7308</b>	Outline Drawing	<b>A-SS63647-675</b>

This is an uncontrolled document once printed or downloaded and is subject to change without notice. Date Created:10/12/2021

SS63647

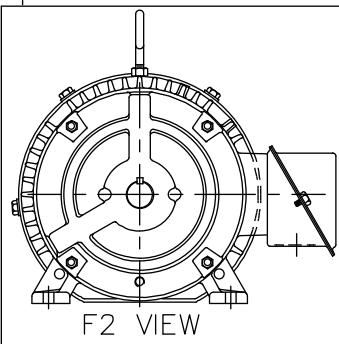
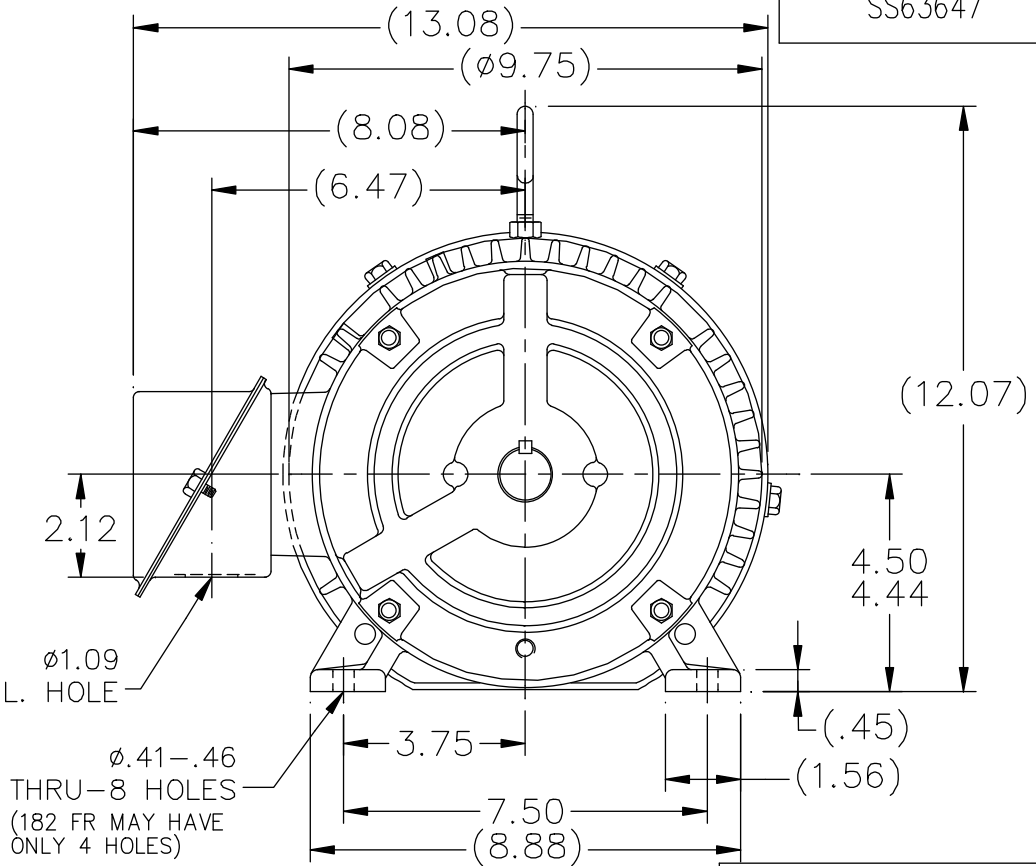
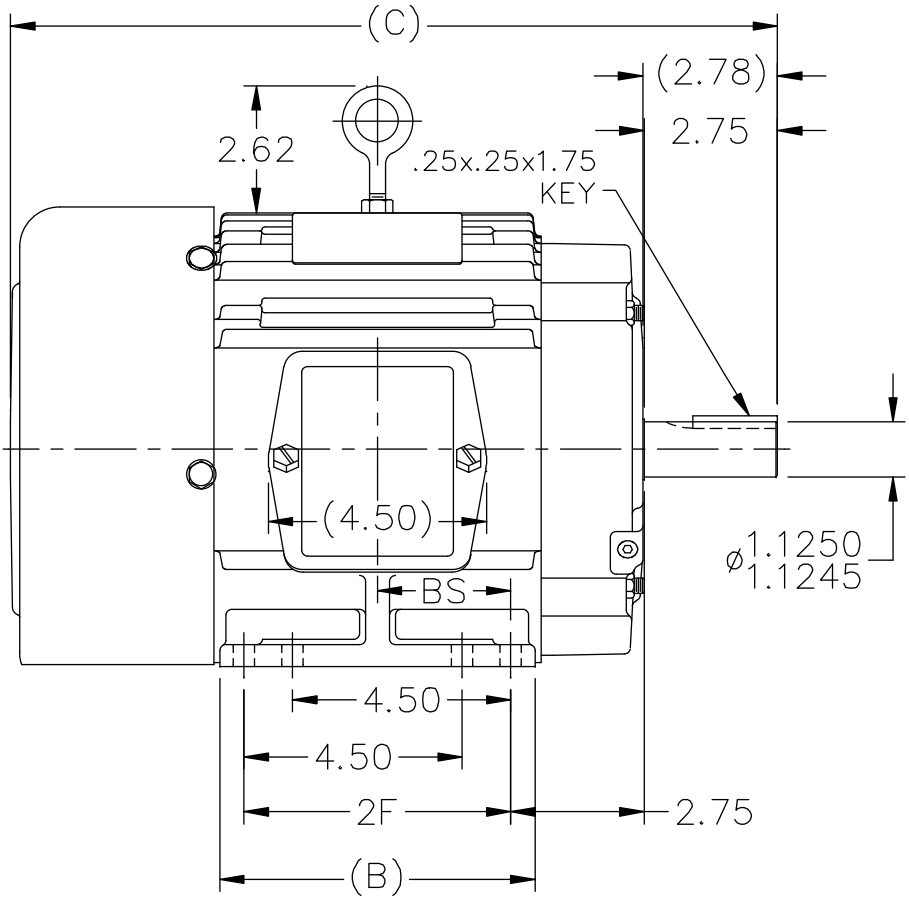

- NOTES:
1. CONDUIT BOX CAN BE ROTATED IN 90° STEPS.
  2. CONDUIT BOX CAN BE MOUNTED ON OPPOSITE SIDE BY REMOVING BRACKETS AND TURNING FRAME 180°
  3. NAMEPLATE TO BE READ FROM CONDUIT BOX SIDE OF MOTOR

DASH	FR.	C	B	2F	BS	MOUNTING
575	182T	14.81	5.50	4.50	2.25	F1 OR F2
675	182/4T	15.81	6.50	5.50	2.75	F1 OR F2
800	182/4T	17.06	7.75	5.50	3.38	F1 ONLY

NO.	REVISION	BY & DATE	CHK	ANG
11	ADDED F2 VIEW	HLB		
10	REVISED DASH 575 WAS F1 ONLY CN 29200-90	CAV 01-31-2000		
9	ADDED 4 EXTRA FOOT HOLES	MRB 07-02-1998		
8	REVISED SHAFT HEIGHT CN 16763	BRH 03-18-1996		
7	REDRAWN ON CADD	SMC 04-20-1993		

TOLERANCES UNLESS SPECIFIED	
DEC.	INCHES
.X	±.1
.XX	±.03
.XXX	±.005
.XXXX	±.0005
	±.7'30"



TITLE OUTLINE  
180T FR. - BB - TS - TEFC

MAT'L.

FINISH

DRAWN	SMC 04-07-1993
CHK	ML 04-12-1993
APPD	GK 04-19-1993
SCALE	1=4
REF	
FMF	
PREV	

THIS DRAWING IN DESIGN AND DETAIL IS OUR PROPERTY AND MUST NOT BE USED EXCEPT IN CONNECTION WITH OUR WORK ALL RIGHTS OF DESIGN AND INVENTION ARE RESERVED THIS IS AN ELECTRONICALLY GENERATED DOCUMENT - DO NOT SCALE THIS PRINT

RFP	CAD FILE ss63647
DIST LB	

SIZE	DRAWING NO.	PAGE	OF	REV.
A	SS63647			11



NO.	REVISION	BY & DATE	CHK	ANG	TOLERANCES UNLESS SPECIFIED		FINISH	DRAWN RM 11/20/1990				
					DEC.	INCHES						
5	CHG TO REGAL LOGO	SL 09/10/2015	AB					CHK ML 11/21/1990				
4	REVISED IEC NOTATIONS	MSG 11/15/2011	CMN	.X	±.1			APPD SAS 04/24/2003				
3	ADDED IEC NOTATIONS... (U1), (V1) ETC. MU95194	MSG 5/10/2010	MJS	.XX	±.02		TITLE CONNECTION DIAGRAM	SCALE 1=1				
2	ADDED THE OPTIONAL CORD CONNECTION MU46318	RDH 04/24/2003	DRS	.XXX	±.005		3Ø - DUAL VOLTAGE MOTOR	REF				
1	REDRAWN	RM 11/20/1990		.XXXX	±.0005		MAT'L.	FMF				
					±7'30"			PREV				
THIS DRAWING IN DESIGN AND DETAIL IS OUR PROPERTY AND MUST NOT BE USED EXCEPT IN CONNECTION WITH OUR WORK ALL RIGHTS OF DESIGN AND INVENTION ARE RESERVED THIS IS AN ELECTRONICALLY GENERATED DOCUMENT - DO NOT SCALE THIS PRINT							RFP	CAD FILE ee7308	SIZE A	DRAWING NO. EE7308	PAGE OF 5	REV. 5
							DIST WP					

**CERTIFICATION DATA SHEET**

**Model#:** 184TTFS6001 AX      **WINDING#:** 1842116 NONE 6  
**CONN. DIAGRAM:** A-EE7308      **ASSEMBLY:** F1/F2 CAPABLE  
**OUTLINE:** A-SS63647-675

**TYPICAL MOTOR PERFORMANCE DATA**

HP	KW	SYNC. RPM	F.L. RPM	FRAME	ENCLOSURE	KVA CODE	DESIGN
5	3.7	3600	3505	184T	TEFC	J	B

PH	Hz	VOLTS	FL AMPS	START TYPE	DUTY	INSL	S.F	AMB°C	ELEVATION
3	60	230/460	11.8/5.9	ACROSS THE LINE	CONTINUOUS	F3	1.15	40	3300

FULL LOAD EFF: 88.5	3/4 LOAD EFF: 89	1/2 LOAD EFF: 88.4	GTD. EFF	ELEC. TYPE	NO LOAD AMPS
FULL LOAD PF: 88.5	3/4 LOAD PF: 85.5	1/2 LOAD PF: 77.5	87.5	SQ CAGE IND RUN	4 / 2

F.L. TORQUE	LOCKED ROTOR AMPS	L.R. TORQUE	B.D. TORQUE	F.L. RISE°C
7.5 LB-FT	81 / 40.5	12 LB-FT 160	22 LB-FT 293	50

SOUND PRESSURE @ 3 FT.	SOUND POWER	ROTOR WK^2	MAX. WK^2	SAFE STALL TIME	STARTS / HOUR	APPROX. MOTOR WGT
72 dBA	82 dBA	0.3 LB-FT^2	5.5 LB-FT^2	15 SEC.	2	125 LBS.

**\*\*\* SUPPLEMENTAL INFORMATION \*\*\***

DE BRACKET TYPE	ODE BRACKET TYPE	MOUNT TYPE	ORIENTATION	SEVERE DUTY	HAZARDOUS LOCATION	DRIP COVER	SCREENS	PAINT
STANDARD	STANDARD	RIGID	HORIZONTAL	FALSE	NONE	FALSE	NONE	BLUE (ENAMEL)

BEARINGS		GREASE	SHAFT TYPE	SPECIAL DE	SPECIAL ODE	SHAFT MATERIAL	FRAME MATERIAL
DE	OPE						
BALL	BALL	POLYREX EM	T	NONE	NONE	1144 STRESSPROOF (C-223)	CAST IRON
6206	6205						

THERMO-PROTECTORS				THERMISTORS	CONTROL	SPACE /n HEATERS
THERMOSTATS	PROTECTORS	WDG RTDs	BRG RTDs			
NONE	NOT	NONE	NONE	NONE	FALSE	NONE VOLTS

If Inverter equals NONE, contact factory for further information

* N O T E S *	INVERTER TORQUE: NONE
	INV. HP SPEED RANGE: NONE
	ENCODER: NONE NONE NONE NONE NONE PPR
BRAKE: NONE NONE NONE P/N NONE NONE NONE NONE FT-LB NONE V NONE Hz	

DATE: 06/28/2017 07:24:04 AM  
 FORM 3531 REV.3 02/07/99  
 \*\* Subject to change without notice.

**Data Sheet**

Date: 29-06-2017  
 Customer: \_\_\_\_\_  
 Attention: \_\_\_\_\_  
 Submitted by: FAREEDA DUDEKULA



184TTFS6001

**Submittal**

Data @ 460 V

**Motor Load Data**

Load	0%	25%	50%	75%	100%	115%	125%	LR
Current (Amps)	2.00	2.40	3.4	4.5	5.9	6.7	7.4	40.5
Torque (ft-lb)	0.00	1.80	3.7	5.5	7.5	8.6	9.4	12.0
RPM	3600	3580	3560	3535	3505	3,490	3480	0
Efficiency (%)		83.1	88.4	89.0	88.5	88.0	87.5	
P.F. (%)	11.5	58.6	77.5	85.5	88.5	89.2	89.8	41.0

**Motor Speed Data**

	LR	Pull-Up	BD	Rated	Idle
Speed (RPM)	0	1800	3000	3505	3600
Current (Amps)	40.5	37.0	25.5	5.9	2.00
Torque (ft-lb)	12.0	10.5	22.0	7.5	0.00

Information Block				
HP	5.0			
Sync. RPM	3600			
Frame	184			
Enclosure	TEFC			
Construction	TFS			
Voltage	230/460 V			
Frequency	60 Hz			
Design	B			
LR Code letter	J			
Service Factor	1.15			
Temp Rise @ FL	50 °C			
Duty	CONT			
Ambient	40 °C			
Elevation	1,000 feet			
Rotor/Shaft wk <sup>2</sup>	0.30 Lb-Ft <sup>2</sup>			
Ref Wdg	1842116 NONE			
Sound Pressure @ 1M	72 dBA			
VFD Rating	NONE			
Outline Dwg	A-SS63647-675			
Conn. Diag	A-EE7308			
Additional Specifications:				
0				
365THFS8036				
EQUIV CKT (OHMS / PHASE)				
R1	R2	X1	X2	Xm
1.3920	1.1300	4.8110	1.8460	124.9600

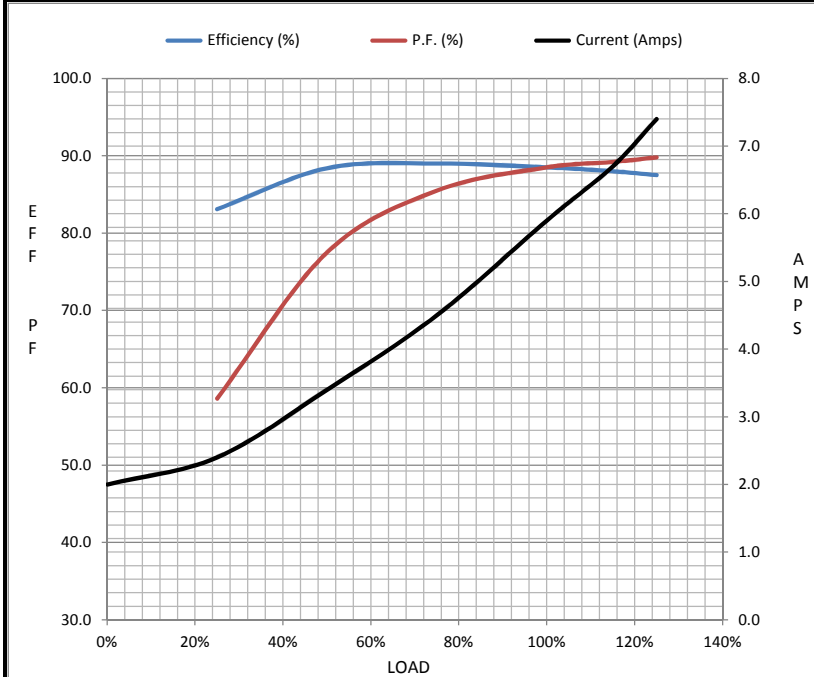

**Speed - Torque Curve**

