

# PRODUCT INFORMATION PACKET

**marathon**<sup>®</sup>  
Motors

Model No: 184TTDR4135

Catalog No: E158

Close-Coupled Pump Motor, 5 & 3 HP, 3 Ph, 60 & 50 Hz, 230/460 & 190/380 V, 1800 & 1500 RPM,  
184JMV Frame, DP

Regal and Marathon are trademarks of Regal Rexnord Corporation or one of its affiliated companies.

©2023 Regal Rexnord Corporation, All Rights Reserved. MC017097E

**RegalRexnord**

### Nameplate Specifications

Phase	<b>3</b>	Output HP	<b>5 &amp; 3 Hp</b>
Output KW	<b>3.7 &amp; 2.2 kW</b>	Voltage	<b>230/460 &amp; 190/380 V</b>
Speed	<b>1745 &amp; 1455 rpm</b>	Service Factor	<b>1.15 &amp; 1.15</b>
Frame	<b>184JMV</b>	Enclosure	<b>Drip Proof</b>
Thermal Protection	<b>No Protection</b>	Efficiency	<b>87.5 &amp; 87.5 %</b>
Ambient Temperature	<b>40 °C</b>	Frequency	<b>60 &amp; 50 Hz</b>
Current	<b>13.2/6.6 &amp; 10.4/5.2 A</b>	Power Factor	<b>81</b>
Duty	<b>Continuous</b>	Insulation Class	<b>B</b>
Design Code	<b>B</b>	KVA Code	<b>J</b>
Drive End Bearing Size	<b>6307</b>	Opp Drive End Bearing Size	<b>6205</b>
UL	<b>Recognized</b>	CSA	<b>Y</b>
CE	<b>Y</b>	IP Code	<b>22</b>
Number of Speeds	<b>1</b>		

### Technical Specifications

Electrical Type	<b>Squirrel Cage Induction Run</b>	Starting Method	<b>Across The Line</b>
Poles	<b>4</b>	Rotation	<b>Reversible</b>
Resistance Main	<b>3.2 Ohms</b>	Mounting	<b>Round</b>
Motor Orientation	<b>Shaft Down</b>	Drive End Bearing	<b>Ball</b>
Opp Drive End Bearing	<b>Ball</b>	Frame Material	<b>Rolled Steel</b>
Shaft Type	<b>JM</b>	Overall Length	<b>17.28 in</b>
Frame Length	<b>7.25 in</b>	Shaft Diameter	<b>0.875 in</b>
Shaft Extension	<b>4.28 in</b>	Assembly/Box Mounting	<b>F1/F2 CAPABLE</b>
Connection Drawing	<b>A-EE7308</b>	Outline Drawing	<b>A-SS65192-725</b>

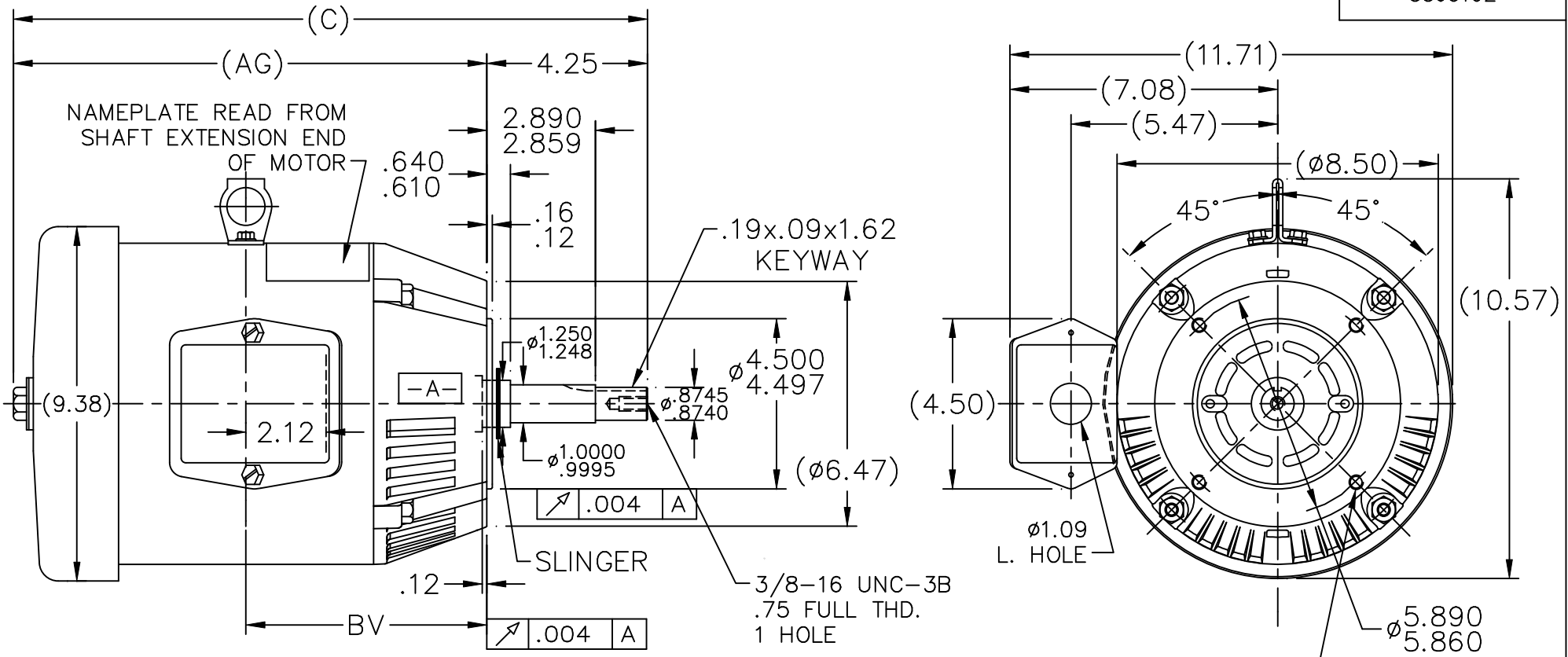

DASH	FR.	AG	C	BV	
575	182/4JM	11.53	15.78	5.88	
625	182/4JM	12.03	16.28	6.13	
675	182/4JM	12.53	16.78	6.38	
725	182/4JM	13.03	17.28	6.63	
775	182/4JM	13.53	17.78	6.88	
825	182/4JM	14.03	18.28	7.13	

BOX CAN BE ROTATED IN 90° STEPS.

NO.		REVISION		BY & DATE		CHK		ANG		±7'30"		FINISH		PREV					
12	UPDATED DRAWING			RJW	05-08-2007	ML	DEC.	INCHES		TOLERANCES UNLESS SPECIFIED		DRAWN SMC 06-09-1992		CHK MOL 06-23-1992					
11	REISSUE - RELOCATED NAMEPLATE GEOMETRY						.X	±.1		MARATHON ELECTRIC		APPD GK 06-23-1992		SCALE 1=4					
	ADDED DASH 625 MU38726, CN34025			DRS	08-30-2001		.XX	±.02		TITLE OUTLINE		REF		REF					
10	ADDED FR. SIZE TO ALL EXCEPT -575 CN27400-320			CAE	08-30-2001		.XXX	±.005		180JM FR.-BB-TS-DR.PR.-VERT.-C'FACE		FMF		PREV					
9	ADDED MOUNTING TYPE CN27451			DRS	04-30-1999		.XXXX	±.0005		MAT'L.		RFP		CAD FILE SS65192					
THIS DRAWING IN DESIGN AND DETAIL IS OUR PROPERTY AND MUST NOT BE USED EXCEPT IN CONNECTION WITH OUR WORK ALL RIGHTS OF DESIGN AND INVENTION ARE RESERVED THIS IS AN ELECTRONICALLY GENERATED DOCUMENT - DO NOT SCALE THIS PRINT										DIST LB		SIZE A		DRAWING NO. SS65192		PAGE OF 12		REV. 12	

EE7308

THREE PHASE  
DUAL VOLTAGE MOTOR



VIEW OF TERMINAL END

REF.  
WINDING DIAGRAM

T8Y, T2Y, T2BL, T4BX, T2EC, T2G  
T6BZ, T2B, T6BL, T4AV, T6B, T4B

OPTIONAL CORD  
CONNECTION

L1 — WHITE  
L2 — RED  
L3 — BLACK

NO.	REVISION	BY & DATE	CHK	ANG	TOLERANCES UNLESS SPECIFIED		FINISH	DRAWN RM 11/20/1990				
					DEC.	INCHES						
5	CHG TO REGAL LOGO	SL 09/10/2015	AB					CHK ML 11/21/1990				
4	REVISED IEC NOTATIONS	MSG 11/15/2011	CMN	.X	±.1			APPD SAS 04/24/2003				
3	ADDED IEC NOTATIONS... (U1), (V1) ETC. MU95194	MSG 5/10/2010	MJS	.XX	±.02		TITLE CONNECTION DIAGRAM	SCALE 1=1				
2	ADDED THE OPTIONAL CORD CONNECTION MU46318	RDH 04/24/2003	DRS	.XXX	±.005		3Ø - DUAL VOLTAGE MOTOR	REF				
1	REDRAWN	RM 11/20/1990		.XXXX	±.0005		MAT'L.	FMF				
					±7'30"			PREV				
THIS DRAWING IN DESIGN AND DETAIL IS OUR PROPERTY AND MUST NOT BE USED EXCEPT IN CONNECTION WITH OUR WORK ALL RIGHTS OF DESIGN AND INVENTION ARE RESERVED THIS IS AN ELECTRONICALLY GENERATED DOCUMENT - DO NOT SCALE THIS PRINT							RFP	CAD FILE ee7308	SIZE A	DRAWING NO. EE7308	PAGE OF 5	REV. 5
							DIST WP					



Regal Beloit America, Inc.