

# PRODUCT INFORMATION PACKET

Model No: 184TTDBD6029

Catalog No: GT0313

Globetrotter® General Purpose Motor, 5 & 3 HP, 3 Ph, 60 & 50 Hz, 230/460 & 190/380 V,  
1800 & 1500 RPM, 184TC Frame, DP



Regal and Marathon are trademarks of Regal Rexnord Corporation or one of its affiliated companies.  
©2024 Regal Rexnord Corporation, All Rights Reserved. MC017097E

### Nameplate Specifications

Phase	<b>3</b>	Output HP	<b>5 &amp; 3 Hp</b>
Output KW	<b>3.7 &amp; 2.2 kW</b>	Voltage	<b>230/460 &amp; 190/380 V</b>
Speed	<b>1765 &amp; 1475 rpm</b>	Service Factor	<b>1.15 &amp; 1.15</b>
Frame	<b>184TC</b>	Enclosure	<b>Drip Proof</b>
Thermal Protection	<b>No Protection</b>	Efficiency	<b>89.5 &amp; 89.5 %</b>
Ambient Temperature	<b>40 °C</b>	Frequency	<b>60 &amp; 50 Hz</b>
Current	<b>13.2/6.6 &amp; 10.4/5.2 A</b>	Power Factor	<b>80</b>
Duty	<b>Continuous</b>	Insulation Class	<b>F</b>
Design Code	<b>A</b>	KVA Code	<b>K</b>
Drive End Bearing Size	<b>6206</b>	Opp Drive End Bearing Size	<b>6203</b>
UL	<b>Recognized</b>	CSA	<b>Y</b>
CE	<b>Y</b>	IP Code	<b>22</b>
Number of Speeds	<b>1</b>		

### Technical Specifications

Electrical Type	<b>Squirrel Cage Inverter Rated</b>	Starting Method	<b>Line Or Inverter</b>
Poles	<b>4</b>	Rotation	<b>Reversible</b>
Resistance Main	<b>2.72 Ohms</b>	Mounting	<b>Round</b>
Motor Orientation	<b>Horizontal</b>	Drive End Bearing	<b>Ball</b>
Opp Drive End Bearing	<b>Ball</b>	Frame Material	<b>Rolled Steel</b>
Shaft Type	<b>T</b>	Shaft Diameter	<b>1.125 in</b>
Assembly/Box Mounting	<b>F1/F2 CAPABLE</b>	Inverter Load	<b>CONSTANT 2:1/VARIABLE 10:1</b>
Connection Drawing	<b>EE7308</b>	Outline Drawing	<b>SS600235-200</b>

This is an uncontrolled document once printed or downloaded and is subject to change without notice. Date Created:10/18/2024

DASH NO.	4				3	
	C	AG	AH	BV	MOUNTING	FRAME
100	13.00	10.37	2.62	7.77	F1 OR F2	182TC
200	14.00	11.37		8.77		184TC

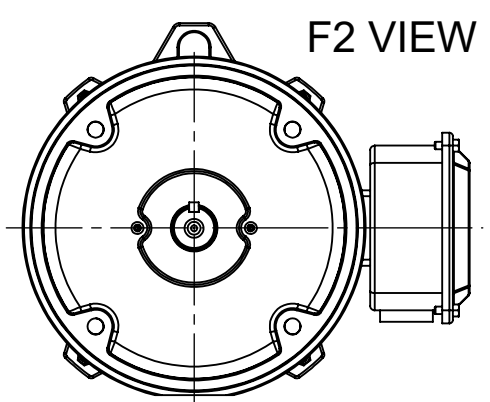
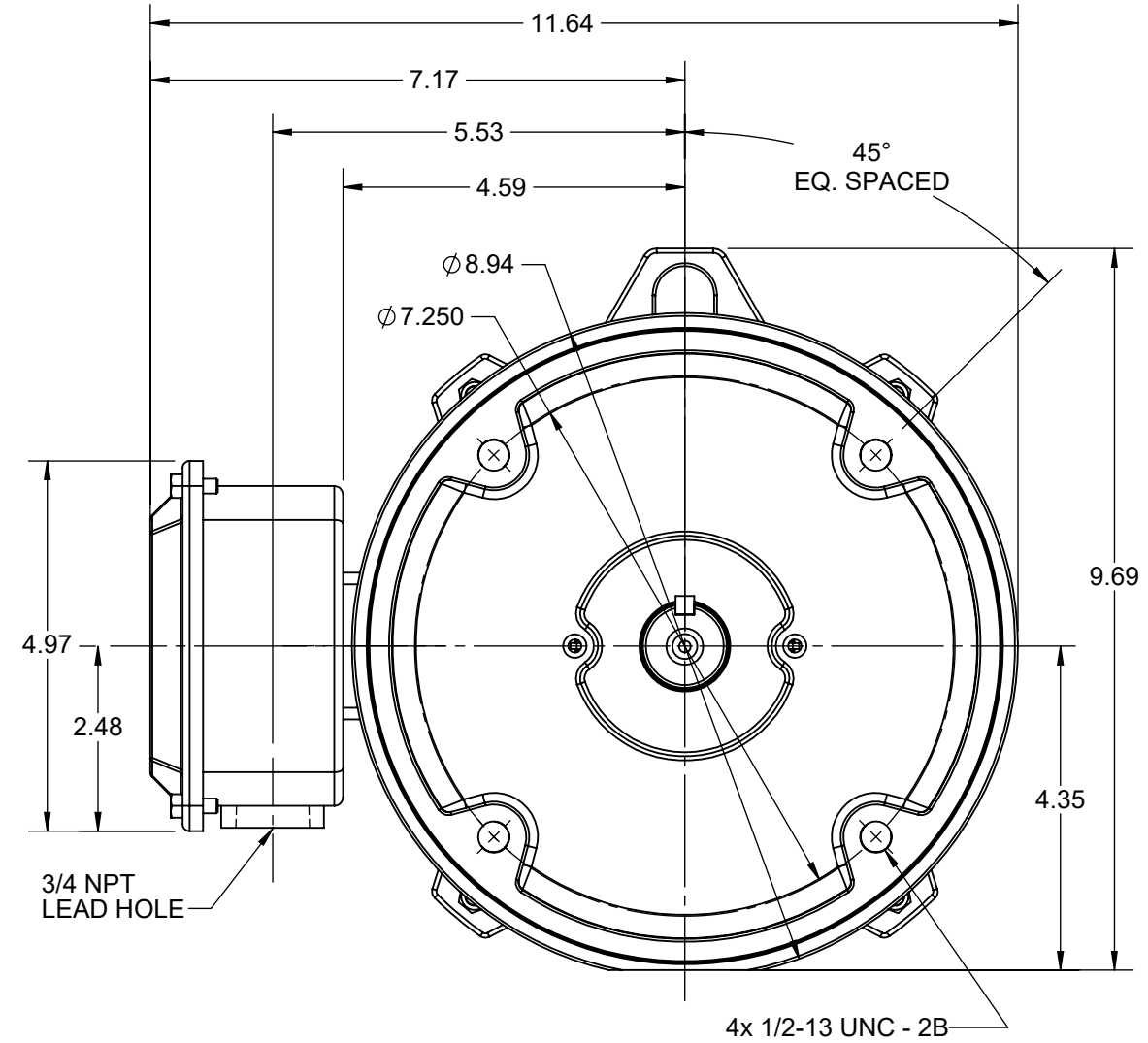
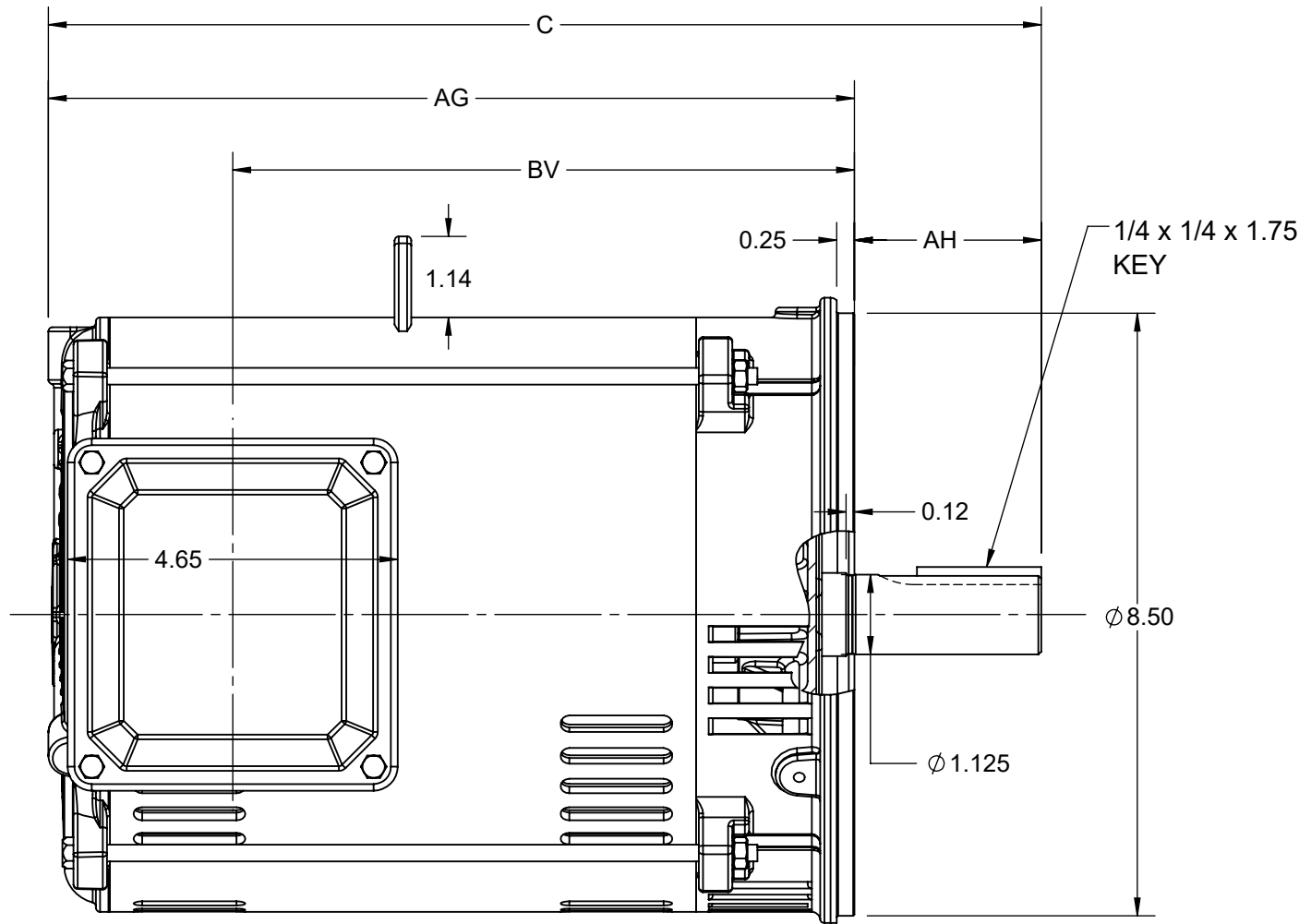

DRAWING REVISION B	REVISION BY BISWA	REV DATE/© DATE 19/01/2021
ECO CR-0000645	APPROVED BY GNK	DATE 19/01/2021
ECO DESCRIPTION <b>DRAWING UPDATED</b>		
<small>COPYRIGHT (PER REVISION DATE) REGAL BELOIT AMERICA, INC. ALL RIGHTS RESERVED. PROPRIETARY AND CONFIDENTIAL INFORMATION - THIS DOCUMENT IS THE PROPERTY OF REGAL BELOIT AMERICA, INC. ("OWNER") AND CONTAINS OWNER'S PROPRIETARY INFORMATION. ANY PERSON, CORPORATION OR OTHER FIRM RECEIVING IT IS DEEMED, BY RECEIVING IT, TO AGREE THAT IT, AND/OR ANY PART OF IT, SHALL NOT BE DISCLOSED TO ANY PERSON, CORPORATION OR OTHER ENTITY, DUPLICATED, AND/OR USED, EXCEPT AS EXPRESSLY APPROVED IN WRITING IN ADVANCE BY OWNER. THIS DOCUMENT SHALL BE RETURNED TO OWNER UPON REQUEST. IT MAY BE SUBJECT TO CERTAIN RESTRICTIONS UNDER APPLICABLE EXPORT CONTROL LAWS AND REGULATIONS.</small>		

PRIMARY DIMENSIONS ARE INCH  
mm DIMENSIONS IN [BRACKETS]  
ARE FOR REFERENCE ONLY

DRAWN BY MSH	<b>REGAL</b> ® Regal Beloit America, Inc.
DATE 20/03/2020	
APPROVED BY SBD	DESCRIPTION <b>OUTLINE</b>
DATE 20/03/2020	NEMA 182/184TC FR ODP RS - ROUND - FOOTLESS
REFERENCE	MATERIAL PROCESS/FINISH
THIRD ANGLE PROJECTION	SIZE B
	DRAWING NUMBER <b>SS600235</b>
	SHEET 1 OF 1

EE7308

THREE PHASE  
DUAL VOLTAGE MOTOR



VIEW OF TERMINAL END

REF.  
WINDING DIAGRAM

T8Y, T2Y, T2BL, T4BX, T2EC, T2G  
T6BZ, T2B, T6BL, T4AV, T6B, T4B

OPTIONAL CORD  
CONNECTION

L1 — WHITE  
L2 — RED  
L3 — BLACK

NO.	REVISION	BY & DATE	CHK	ANG	TOLERANCES UNLESS SPECIFIED		FINISH	DRAWN RM 11/20/1990				
					DEC.	INCHES						
5	CHG TO REGAL LOGO	SL 09/10/2015	AB					CHK ML 11/21/1990				
4	REVISED IEC NOTATIONS	MSG 11/15/2011	CMN	.X	±.1			APPD SAS 04/24/2003				
3	ADDED IEC NOTATIONS... (U1), (V1) ETC. MU95194	MSG 5/10/2010	MJS	.XX	±.02		TITLE CONNECTION DIAGRAM	SCALE 1=1				
2	ADDED THE OPTIONAL CORD CONNECTION MU46318	RDH 04/24/2003	DRS	.XXX	±.005		3Ø - DUAL VOLTAGE MOTOR	REF				
1	REDRAWN	RM 11/20/1990		.XXXX	±.0005		MAT'L.	FMF				
					±7'30"			PREV				
THIS DRAWING IN DESIGN AND DETAIL IS OUR PROPERTY AND MUST NOT BE USED EXCEPT IN CONNECTION WITH OUR WORK ALL RIGHTS OF DESIGN AND INVENTION ARE RESERVED THIS IS AN ELECTRONICALLY GENERATED DOCUMENT - DO NOT SCALE THIS PRINT							RFP	CAD FILE ee7308	SIZE A	DRAWING NO. EE7308	PAGE OF 5	REV. 5
							DIST WP					



Regal Beloit America, Inc.