

# PRODUCT INFORMATION PACKET

Model No: 184TPTSC10321

Catalog No: NM2412

NovaMAX™ EC Permanent Magnet Fan & Blower Motor, 10 HP, 3 Ph, 180 Hz, 460 V, 3600 RPM, 184T Frame,  
TEAO



Regal and Marathon are trademarks of Regal Rexnord Corporation or one of its affiliated companies.

©2023 Regal Rexnord Corporation, All Rights Reserved. MC017097E



### Nameplate Specifications

Phase	<b>3</b>	Output HP	<b>10 Hp</b>
Output KW	<b>7.5 kW</b>	Voltage	<b>460 V</b>
Speed	<b>3600 rpm</b>	Service Factor	<b>1.15</b>
Frame	<b>184T</b>	Enclosure	<b>Totally Enclosed Air Over</b>
Thermal Protection	<b>No Protection</b>	Efficiency	<b>94 %</b>
Ambient Temperature	<b>40 °C</b>	Frequency	<b>180 Hz</b>
Current	<b>11.3 A</b>	Duty	<b>Continuous</b>
Insulation Class	<b>F</b>	Design Code	<b>No Design Code</b>
KVA Code	<b>N/A</b>	Drive End Bearing Size	<b>6207</b>
Opp Drive End Bearing Size	<b>6207</b>	UL	<b>Recognized</b>
CSA	<b>N</b>	CE	<b>N</b>
IP Code	<b>54</b>	Number of Speeds	<b>1</b>

### Technical Specifications

Electrical Type	<b>AC Permanent Magnet</b>	Starting Method	<b>Inverter Only</b>
Poles	<b>6</b>	Rotation	<b>Reversible</b>
Resistance Main	<b>0 Ohms</b>	Mounting	<b>Rigid Base</b>
Motor Orientation	<b>Horizontal</b>	Drive End Bearing	<b>Ball</b>
Opp Drive End Bearing	<b>Ball</b>	Frame Material	<b>Cast Iron</b>
Shaft Type	<b>T</b>	Overall Length	<b>14.66 in</b>
Frame Length	<b>9.42 in</b>	Shaft Diameter	<b>1.123 in</b>
Shaft Extension	<b>2.75 in</b>	Assembly/Box Mounting	<b>F1 ONLY</b>
Inverter Load	<b>VARIABLE 20:1</b>		
Outline Drawing	<b>520-00505-9419</b>	Connection Drawing	<b>NA</b>

DASH	FRAME	C	B	2F	2FF	BS
9419	182/184	14.66 [372.39]	7.44 [188.93]	4.50 [114.30]	5.50 [139.70]	2.99 [75.98]

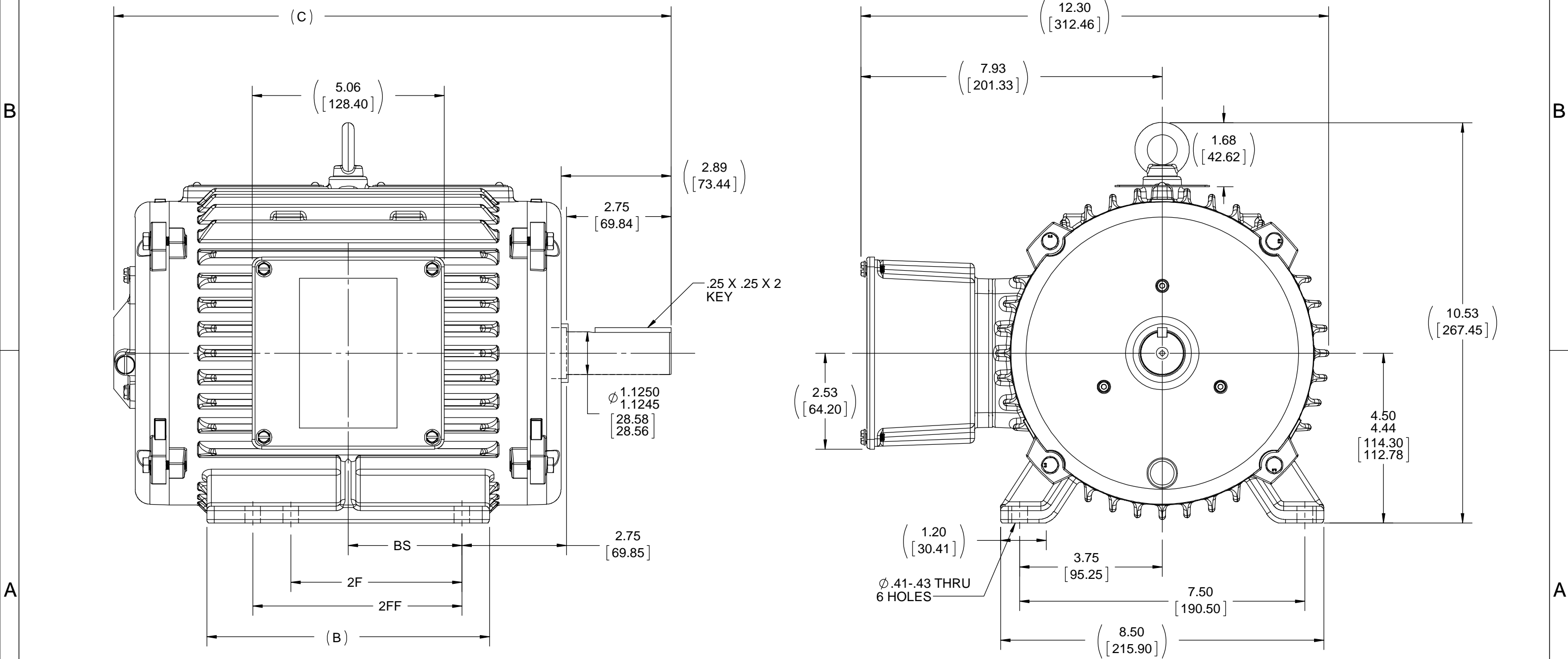

- NOTES: (UNLESS OTHERWISE SPECIFIED)
- ALL DIMENSIONS & TOLERANCES APPLY POST-FINISH OR PLATING.
  - CRITICAL TO FUNCTION DIMENSIONS ARE INSIDE OVAL BORDER. QUERY SOLID MODEL (IGES) FOR COMPLETE PART DEFINITION.

DRAWING REVISION C	REVISION BY GNK	DATE 08/09/2018
ECO ECO-0150486	APPROVED BY GNK	DATE 08/09/2018
ECO DESCRIPTION SHEET 1 DELETED		
<small>COPYRIGHT REGAL BELOIT AMERICA, INC. ALL RIGHTS RESERVED. PROPRIETARY AND CONFIDENTIAL INFORMATION - THIS DOCUMENT IS THE PROPERTY OF REGAL BELOIT AMERICA, INC. ("OWNER") AND CONTAINS OWNER'S PROPRIETARY INFORMATION. ANY PERSON, CORPORATION OR OTHER FIRM RECEIVING IT IS DEEMED, BY RECEIVING IT, TO AGREE THAT IT, AND/OR ANY PART OF IT, SHALL NOT BE DISCLOSED TO ANY PERSON, CORPORATION OR OTHER ENTITY, DUPLICATED, AND/OR USED, EXCEPT AS EXPRESSLY APPROVED IN WRITING IN ADVANCE BY OWNER. THIS DOCUMENT SHALL BE RETURNED TO OWNER UPON REQUEST. IT MAY BE SUBJECT TO CERTAIN RESTRICTIONS UNDER APPLICABLE EXPORT CONTROL LAWS AND REGULATIONS.</small>		

TOLERANCES UNLESS OTHERWISE SPECIFIED:			
DEC.	mm	INCH	ANGLE
.X	±2.5	[±0.10]	±0.5°
.XX	±0.25	[±0.010]	
.XXX	±0.130	[±0.0051]	
.XXXX	±0.0130	[±0.00051]	
REMOVE BURRS & BREAK SHARP EDGES: .08/.38 [.003/.015] X 45°			
CORNER FILLETS: R.50 [.020]			
MACHINED SURFACES: 125 3.2			
INCH SHOWN IN [BRACKETS]			

DRAWN BY	<b>REGAL</b> ™ Regal Beloit America, Inc.	
DATE	DESCRIPTION	
APPROVED BY	OUTLINE	
DATE	NOVAMAX, 182/184T, TEAO/TENV, RIGID	
REFERENCE	MATERIAL	PROCESS/FINISH
THIRD ANGLE PROJECTION	SIZE B	DRAWING NUMBER 520-00505
		SHEET 1 OF 1