

# PRODUCT INFORMATION PACKET

Model No: 184TBFW17045

Catalog No: Z120A

General Purpose Farm Duty Motor, 3 HP, 1 Ph, 60 Hz, 230 V, 1800 RPM, 184T Frame, TEFC



Regal and are trademarks of Regal Rexnord Corporation or one of its affiliated companies.  
©2022 Regal Rexnord Corporation, All Rights Reserved. MC017097E

### Nameplate Specifications

Output HP	<b>3 Hp</b>	Output KW	<b>2.2 kW</b>
Frequency	<b>60 Hz</b>	Voltage	<b>230 V</b>
Current	<b>14.2 A</b>	Speed	<b>1755 rpm</b>
Service Factor	<b>1.15</b>	Phase	<b>1</b>
Efficiency	<b>80 %</b>	Power Factor	<b>86</b>
Duty	<b>Continuous</b>	Insulation Class	<b>F</b>
Design Code	<b>NO DESIGN CODE</b>	KVA Code	<b>K</b>
Frame	<b>184T</b>	Enclosure	<b>Totally Enclosed Fan Cooled</b>
Thermal Protection	<b>Manual</b>	Ambient Temperature	<b>40 °C</b>
Drive End Bearing Size	<b>6206</b>	Opp Drive End Bearing Size	<b>6205</b>
UL	<b>Recognized ( Not Protector)</b>	CSA	<b>Y</b>
CE	<b>Y</b>	IP Code	<b>43</b>
Number of Speeds	<b>1</b>		

### Technical Specifications

Electrical Type	<b>Capacitor Start Capacitor Run</b>	Starting Method	<b>Across The Line</b>
Poles	<b>4</b>	Rotation	<b>Selective Counterclockwise</b>
Resistance Main	<b>.68 Ohms</b>	Mounting	<b>Rigid Base</b>
Motor Orientation	<b>Horizontal</b>	Drive End Bearing	<b>Ball</b>
Opp Drive End Bearing	<b>Ball</b>	Frame Material	<b>Rolled Steel</b>
Shaft Type	<b>T</b>	Overall Length	<b>14.96 in</b>
Frame Length	<b>9.50 in</b>	Shaft Diameter	<b>1.125 in</b>
Shaft Extension	<b>2.81 in</b>	Assembly/Box Mounting	<b>F1 ONLY</b>
Outline Drawing	<b>035584-950</b>	Connection Drawing	<b>005056.03ME</b>

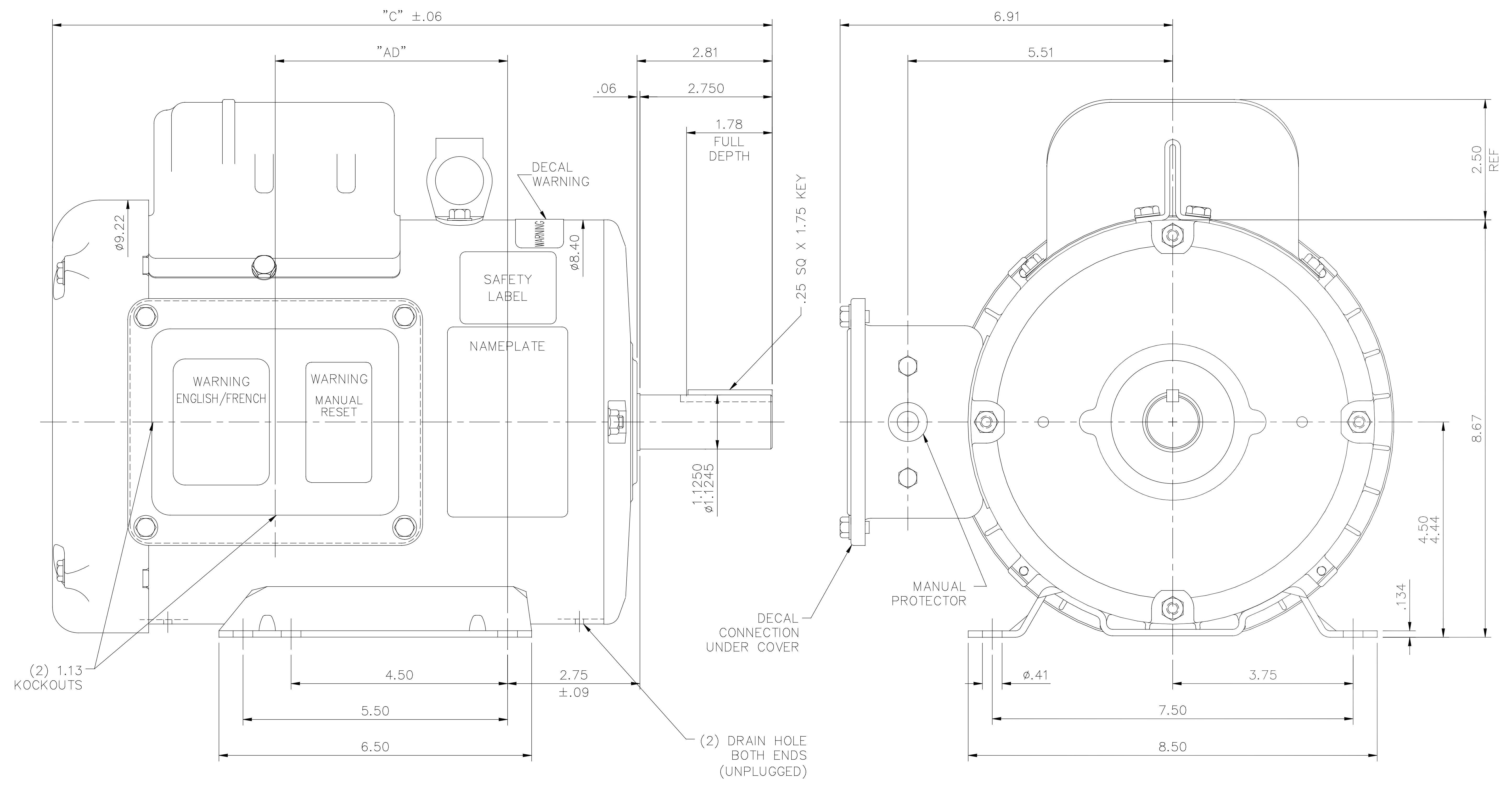

GASKETS THROUGHOUT

DASH NO.	"C"	"AD"
900	14.46	4.33
950	14.96	4.83
1000	15.46	5.33
1050	15.96	5.83
1100	16.46	6.33
1150	16.96	6.83
1200	17.46	7.33

NO.		REVISION	BY & DATE	CHK	ANG	TOLERANCES UNLESS SPECIFIED	 <b>Regal Beloit America, Inc.</b>	DRAWN KVN 10/15/2007				
						DEC.		INCHES	CHK	APPD		
03		DRAIN HOLES ADDED	KIR 02/08/16	SS	.XX	±.03	TITLE OUTLINE - 180T FRAME TEFC - RIGID	SCALE	1=2			
02		MANUAL PROT. DECAL WAS 004075-01	GWS 3/5/10		.XXX	±.005		REF	035474			
01		DASH NO. 900 ADDED IN DIMENSION BOX	KVN 3/8/2008		.XXXX	±.0005		MAT'L.	FMF 184TBFW7070			
							FINISH	PREV				
THIS DRAWING IN DESIGN AND DETAIL IS OUR PROPERTY AND MUST NOT BE USED EXCEPT IN CONNECTION WITH OUR WORK ALL RIGHTS OF DESIGN AND INVENTION ARE RESERVED THIS IS AN ELECTRONICALLY GENERATED DOCUMENT - DO NOT SCALE THIS PRINT							RFP	CAD FILE	035584	SIZE	DRAWING NO.	REV.
							DIST	NLV	B	035584	03	

VIEW FROM OUTSIDE OF MOTOR AT SWITCH END.

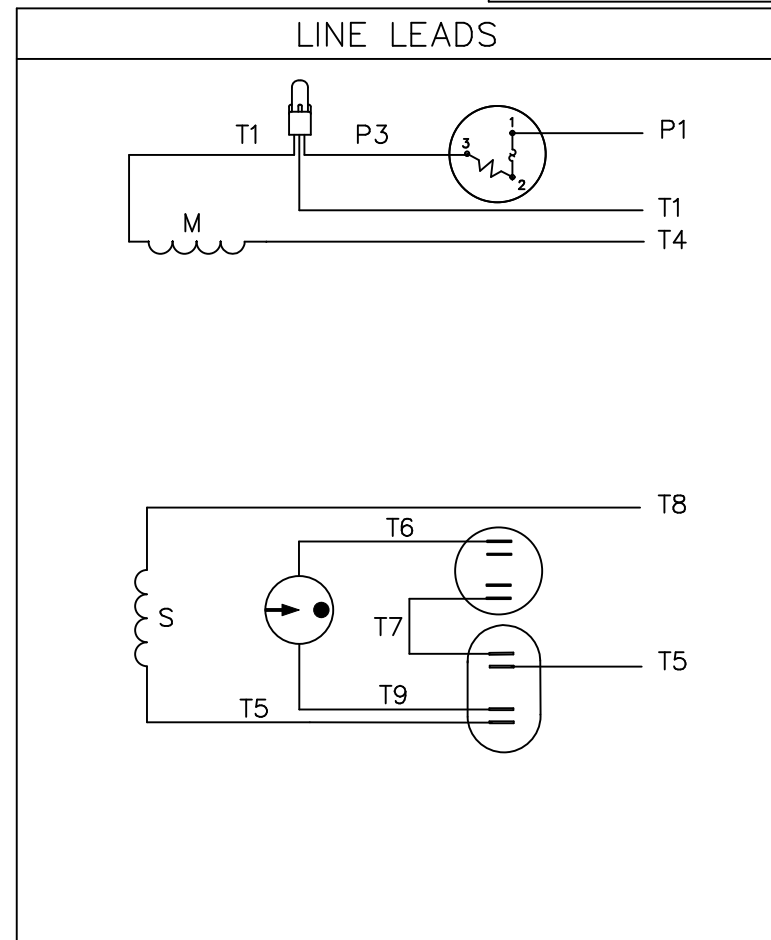
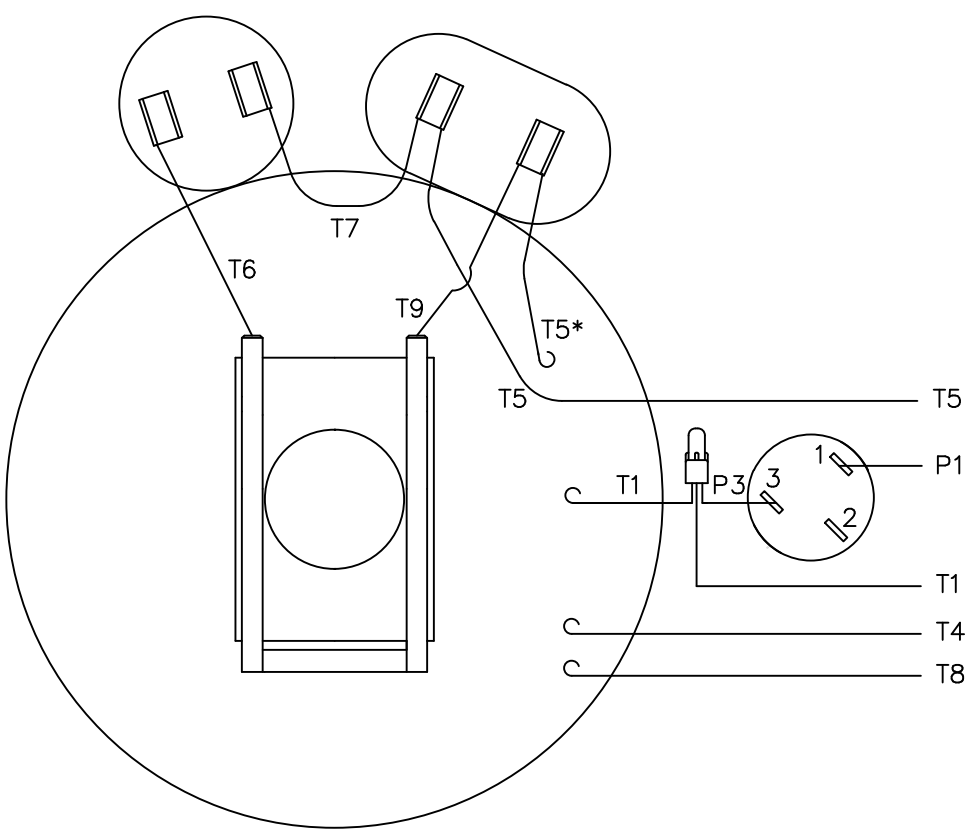

ROTATION FACING LEAD END	L1	L2	JOIN
C.C.W.	P1	T4, T5	T1, T8
C.W.	P1	T4, T8	T1, T5

\* THIS LEAD MAY BE WHITE

		TOLERANCES UNLESS SPECIFIED		REGAL-BELOIT <i>Motor Technologies</i>		DRAWN LST 9/9/03	
		DEC.	INCHES	TITLE		CHK KH 9/9/03	
		.X	±.1	EXTERNAL WIRING DIAGRAM		APPD	
		.XX	±.01	TYPE "K" W/ PROTECTOR		SCALE 1=1	
		.XXX	±.005	MAT'L. DECAL - 004015		REF	
		.XXXX	±.0005	FINISH		FMF 139045	
NO.	REVISION	BY & DATE	CHK	ANG	±1/2"	PREV	
THIS DRAWING IN DESIGN AND DETAIL IS OUR PROPERTY AND MUST NOT BE USED EXCEPT IN CONNECTION WITH OUR WORK ALL RIGHTS OF DESIGN AND INVENTION ARE RESERVED THIS IS AN ELECTRONICALLY GENERATED DOCUMENT - DO NOT SCALE THIS PRINT			RFP	CAD FILE 00505603ME		SIZE	DRAWING NO.
			DIST	BRF-NLV		A	005056-03ME
							REV.

**CERTIFICATION DATA SHEET**

**Model#:** 184TBFW17045 AA  
**CONN. DIAGRAM:** 005056.03ME  
**OUTLINE:** 035584-950

**WINDING#:** K84100 NONE 2  
**ASSEMBLY:** F1 ONLY

**TYPICAL MOTOR PERFORMANCE DATA**

HP	KW	SYNC. RPM	F.L. RPM	FRAME	ENCLOSURE	KVA CODE	DESIGN
3	2.24	1800	1755	184T	TEFC	K	NO DESIGN CODE

PH	Hz	VOLTS	FL AMPS	START TYPE	DUTY	INSL	S.F	AMB°C	ELEVATION
1	60	230	14.2	ACROSS THE LINE	CONTINUOUS	F4	1.15	40	3300

FULL LOAD EFF: 80	3/4 LOAD EFF: 80	1/2 LOAD EFF: 75.5	GTD. EFF	ELEC. TYPE	NO LOAD AMPS
FULL LOAD PF: 86	3/4 LOAD PF: 80	1/2 LOAD PF: 70.5	0	CAP START CAP RUN	6.8

F.L. TORQUE	LOCKED ROTOR AMPS	L.R. TORQUE	B.D. TORQUE	F.L. RISE°C
9 LB-FT	115	27.5 LB-FT 306	26 LB-FT 289	70

SOUND PRESSURE @ 3 FT.	SOUND POWER	ROTOR WK^2	MAX. WK^2	SAFE STALL TIME	STARTS /HOUR	APPROX. MOTOR WGT
0 dBA	10 dBA	0.357 LB-FT^2	0.4 LB-FT^2	10 SEC.	0	0 LBS.

**\*\*\* SUPPLEMENTAL INFORMATION \*\*\***

DE BRACKET TYPE	ODE BRACKET TYPE	MOUNT TYPE	ORIENTATION	SEVERE DUTY	HAZARDOUS LOCATION	DRIP COVER	SCREENS	PAINT
STANDARD	STANDARD	RIGID	HORIZONTAL	FALSE	NONE	FALSE	NONE	BLUE (ENAMEL)

BEARINGS		GREASE	SHAFT TYPE	SPECIAL DE	SPECIAL ODE	SHAFT MATERIAL	FRAME MATERIAL
DE	OPE						
BALL	BALL	POLYREX EM	T	NONE	NONE	AISI 1045 (C-240)	ROLLED STEEL
6206	6205						

THERMO-PROTECTORS				THERMISTORS	CONTROL	SPACE /n HEATERS
THERMOSTATS	PROTECTORS	WDG RTDs	BRG RTDs			
NONE	MANUAL	NONE	NONE	NONE	FALSE	NONE VOLTS

If Inverter equals NONE, contact factory for further information

\*  
N  
O  
T  
E  
S  
\*

INVERTER TORQUE: NONE
INV. HP SPEED RANGE: NONE
ENCODER: NONE
NONE NONE
NONE NONE PPR
BRAKE: NONE NONE
NONE P/N NONE
NONE NONE
NONE FT-LB NONE V NONE Hz

DATE: 07/08/2017 12:49:05 AM  
 FORM 3531 REV.3 02/07/99  
 \*\* Subject to change without notice.



**MARATHON ELECTRIC CORPORATION**  
TYPICAL PERFORMANCE CURVE for AC MOTOR

Customer

Curve at

230

Volts

HP 3

PHASE 1

Model No 184TBFW17045

60

HZ

VOLTS 230

3

HP

HZ 60

RPM 1755

Catalog No Z120A

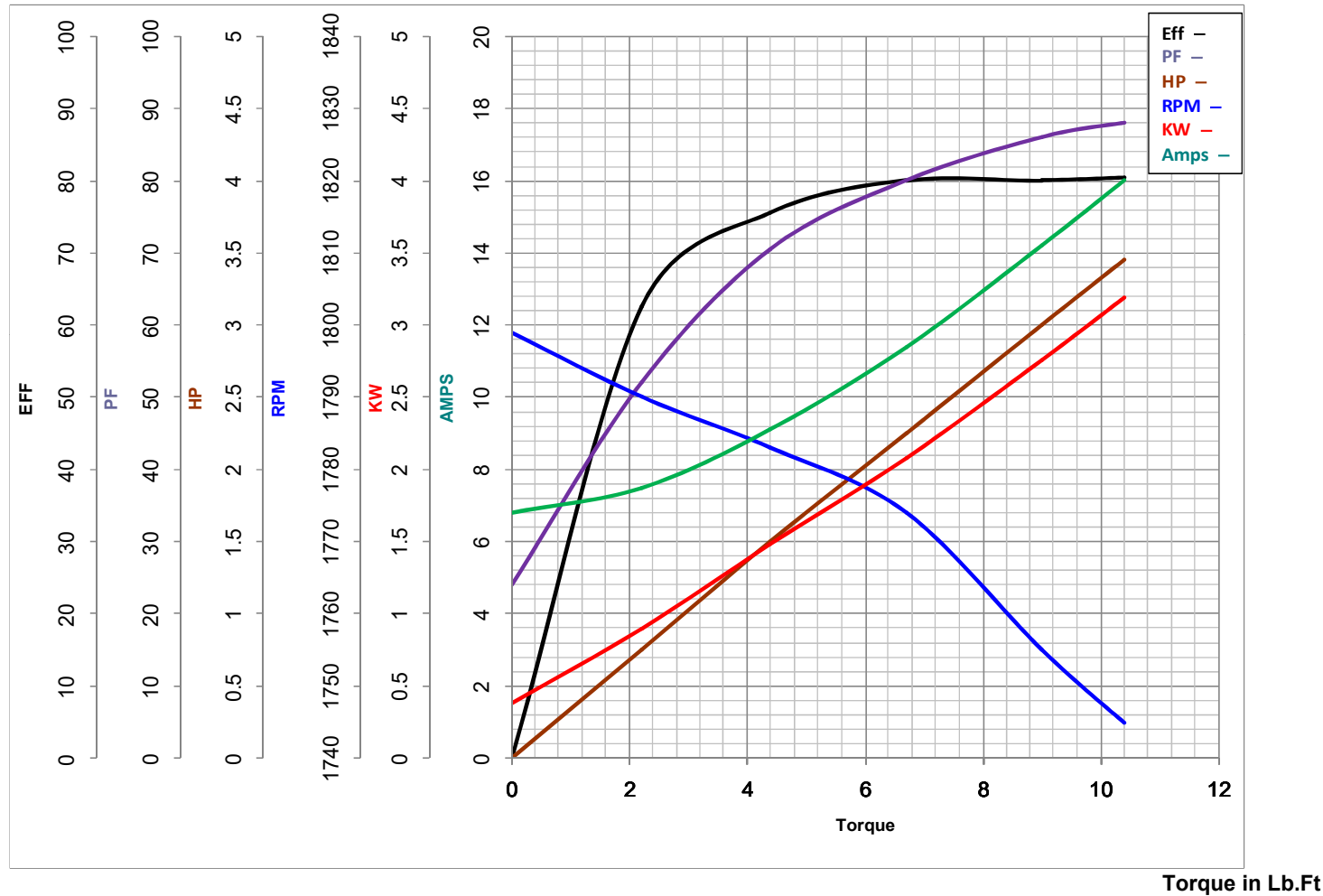

Torque in Lb.Ft

FL TORQUE 19 Lb.Ft  
BD TORQUE 26.0 Lb.Ft  
LR TORQUE 27.5 Lb.Ft

FL AMPS 14.2  
PU TORQUE 23.2 Lb.Ft  
LR AMPS 115

WINDING K84100-2

Date 1/10/2019