

PRODUCT INFORMATION PACKET

Model No: 184TBDR7632

Catalog No: I131

Pressure Washer Motor, 5 HP, 1 Ph, 60 Hz, 208-230 V, 1800 RPM, 184T Frame, DP



Regal and are trademarks of Regal Rexnord Corporation or one of its affiliated companies.
©2022 Regal Rexnord Corporation, All Rights Reserved. MC017097E

Nameplate Specifications

Output HP	5 Hp	Output KW	3.7 kW
Frequency	60 Hz	Voltage	208-230 V
Current	25.0-24.1-24.1 A	Speed	1760 rpm
Service Factor	1.15	Phase	1
Efficiency	81.5 %	Power Factor	82.5
Duty	Continuous	Insulation Class	B
Design Code	NO DESIGN CODE	KVA Code	H
Frame	184T	Enclosure	Drip Proof
Thermal Protection	No Protection	Ambient Temperature	40 °C
Drive End Bearing Size	6206	Opp Drive End Bearing Size	6205
UL	Recognized	CSA	Y
CE	Y	IP Code	22
Number of Speeds	1		

Technical Specifications

Electrical Type	Capacitor Start Capacitor Run	Starting Method	Across The Line
Poles	4	Rotation	Selective Clockwise
Resistance Main	0 Ohms	Mounting	Rigid Base
Motor Orientation	Horizontal	Drive End Bearing	Ball
Opp Drive End Bearing	Ball	Frame Material	Rolled Steel
Shaft Type	T	Overall Length	16.29 in
Frame Length	9.25 in	Shaft Diameter	1.125 in
Shaft Extension	2.78 in	Assembly/Box Mounting	F1 ONLY
Connection Drawing	A-EE9048MA	Outline Drawing	A-SS67836-925

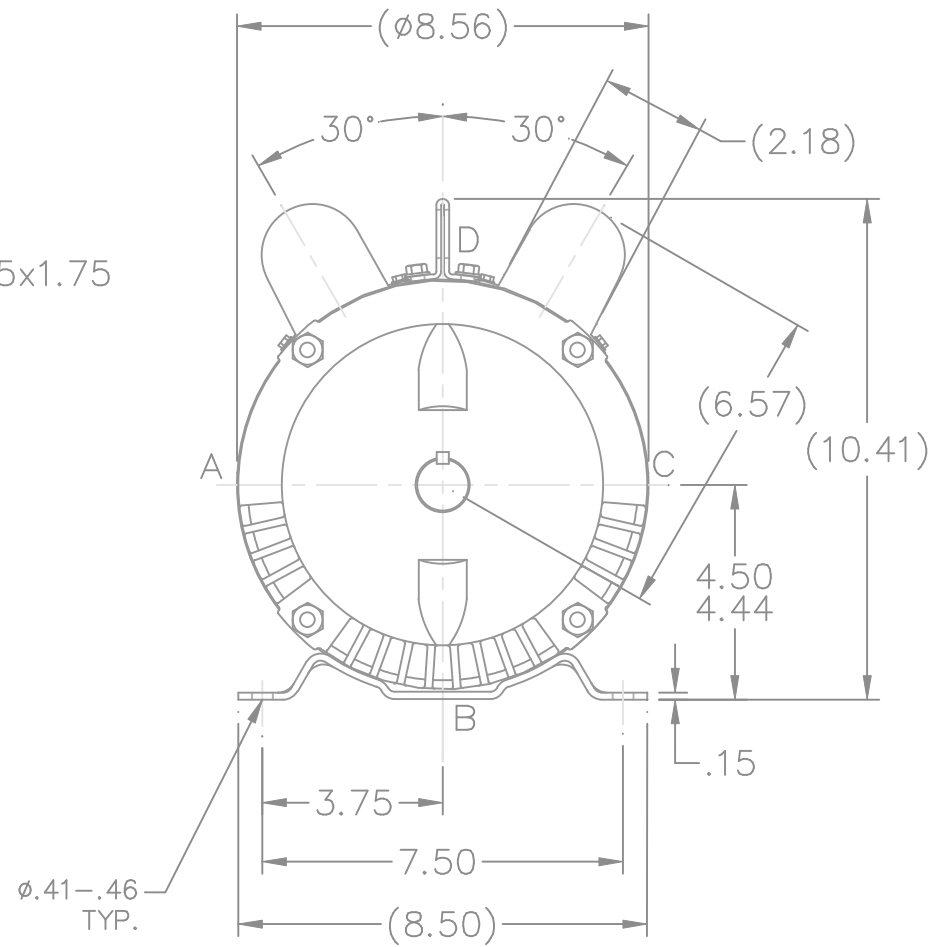
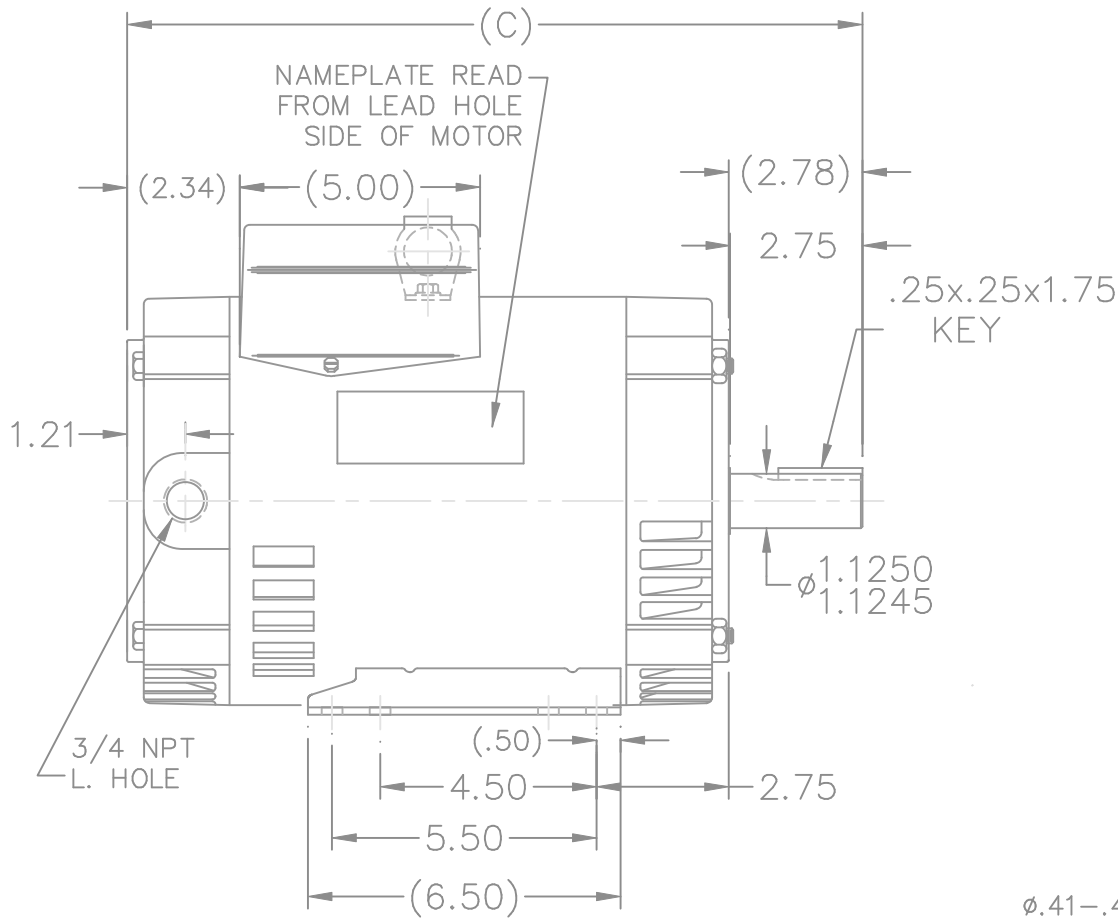

DASH	FR.	C
825	182T	15.29
825	184T	15.29
875	184T	15.79
925	184T	16.29

			TOLERANCES UNLESS SPECIFIED		MARATHON ELECTRIC	DRAWN LZ 09-18-1994			
			DEC.	INCHES		CHK ML 09-29-1994	APPD GK 09-29-1994		
5	ADDED LIFT LUG CN34025	HLB 07-19-2001	.X	±.1	TITLE OUTLINE 180T FR. - DR. PR.	SCALE 1=4			
4	CLARIFIED REMOVAL OF EYEBOLT CLARIFIED SHAFT DIA. CN23925-617	MRB 11-21-1997	.XX	±.03		REF A-SS67836	FMF		
3	ADDED NEW BASE (68105-2) CN14442	MRB 11-06-1995	.XXX	±.005	MAT'L.	PREV			
NO.	REVISION	BY & DATE	CHK	ANG	FINISH				
			RFP	09-29-1994	CAD FILE SS67836	SIZE A	DRAWING NO. SS67836	PAGE OF	REV. 5
			DIST	LB					

C.C.W. ROTATION

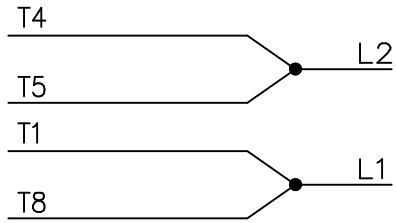

C.W. ROTATION

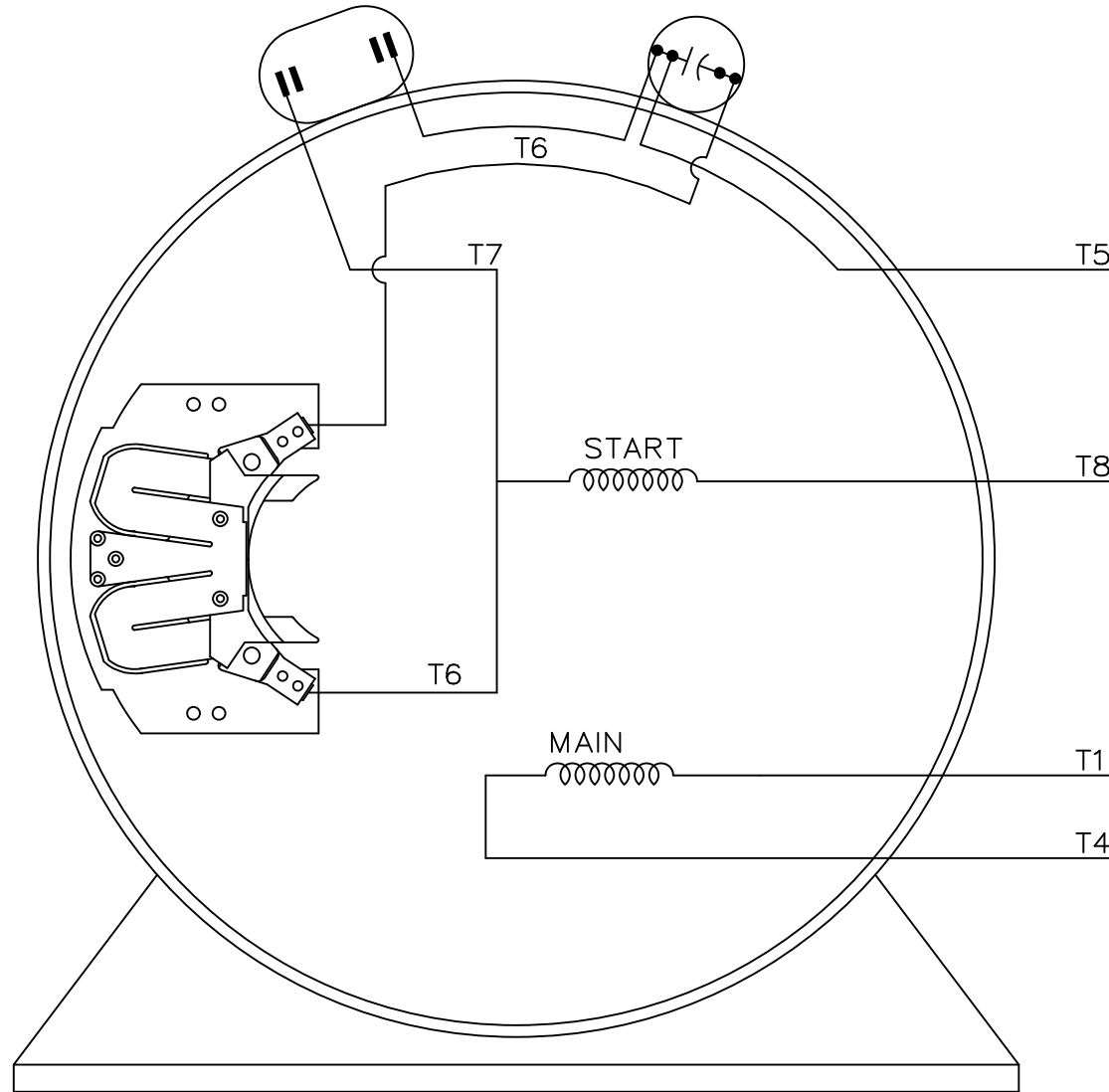
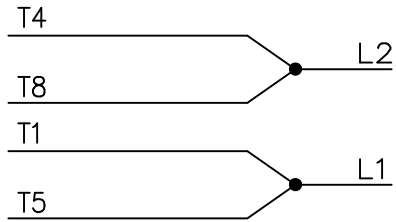

SINGLE VOLTAGE
CAPACITOR START
CAPACITOR RUN
REVERSIBLE

VIEW OF TERMINAL END

				TOLERANCES UNLESS SPECIFIED			DRAWN GK 01-10-1987		
				DEC.	INCHES		CHK		
				.X	± -		APPD		
				.XX	± -		SCALE		
				.XXX	± -		REF		
1	NEW DRAWING	CN-7664C	GK 01-10-1987	.XXXX	± -	MAT'L.	FMF		
NO.	REVISION	BY & DATE	CHK	ANG	± -	FINISH	PREV		
THIS DRAWING IN DESIGN AND DETAIL IS OUR PROPERTY AND MUST NOT BE USED EXCEPT IN CONNECTION WITH OUR WORK ALL RIGHTS OF DESIGN AND INVENTION ARE RESERVED THIS IS AN ELECTRONICALLY GENERATED DOCUMENT - DO NOT SCALE THIS PRINT				RFP	CAD FILE EE9048MA		SIZE A	DRAWING NO. EE9048MA	REV. 1
				DIST					

ERROR: undefined
OFFENDING COMMAND: my

STACK:

/\$x