

# PRODUCT INFORMATION PACKET

Model No: 182TTGCD6530

Catalog No: U023B

Hazardous Duty® Explosion Proof Motor, 3 HP, 3 Ph, 60 Hz, 575 V, 1800 RPM, 182T Frame, EPFC



Regal and Marathon are trademarks of Regal Rexnord Corporation or one of its affiliated companies.  
©2024 Regal Rexnord Corporation, All Rights Reserved. MC017097E

### Nameplate Specifications

Phase	<b>3</b>	Output HP	<b>3 Hp</b>
Output KW	<b>2.2 kW</b>	Voltage	<b>575 V</b>
Speed	<b>1762 rpm</b>	Service Factor	<b>1.0</b>
Frame	<b>182T</b>	Enclosure	<b>Explosion Proof Fan cooled</b>
Thermal Protection	<b>Thermostat</b>	Efficiency	<b>89.5 %</b>
Ambient Temperature	<b>50 °C</b>	Frequency	<b>60 Hz</b>
Current	<b>3.2 A</b>	Power Factor	<b>78</b>
Duty	<b>Continuous</b>	Insulation Class	<b>F</b>
Design Code	<b>B</b>	KVA Code	<b>K</b>
Drive End Bearing Size	<b>6206</b>	Opp Drive End Bearing Size	<b>6206</b>
UL	<b>UL Listed And CSA Certified</b>	CSA	<b>Y</b>
CE	<b>N</b>	IP Code	<b>54</b>
Number of Speeds	<b>1</b>	Hazardous Location	<b>DIV 1 EXP PROOF CL I GR CD CL II GR FG T3C</b>

### Technical Specifications

Electrical Type	<b>Squirrel Cage Inverter Rated</b>	Starting Method	<b>Part Wdg Start Or Inverter</b>
Poles	<b>4</b>	Rotation	<b>Reversible</b>
Resistance Main	<b>4.15 Ohms</b>	Mounting	<b>Rigid Base</b>
Motor Orientation	<b>Horizontal</b>	Drive End Bearing	<b>Ball</b>
Opp Drive End Bearing	<b>Ball</b>	Frame Material	<b>Cast Iron</b>
Shaft Type	<b>T</b>	Shaft Diameter	<b>1.125 in</b>
Assembly/Box Mounting	<b>F1 ONLY</b>	Inverter Load	<b>CONSTANT 10:1</b>
Connection Drawing	<b>A-EE7300T</b>	Outline Drawing	<b>035660-800</b>

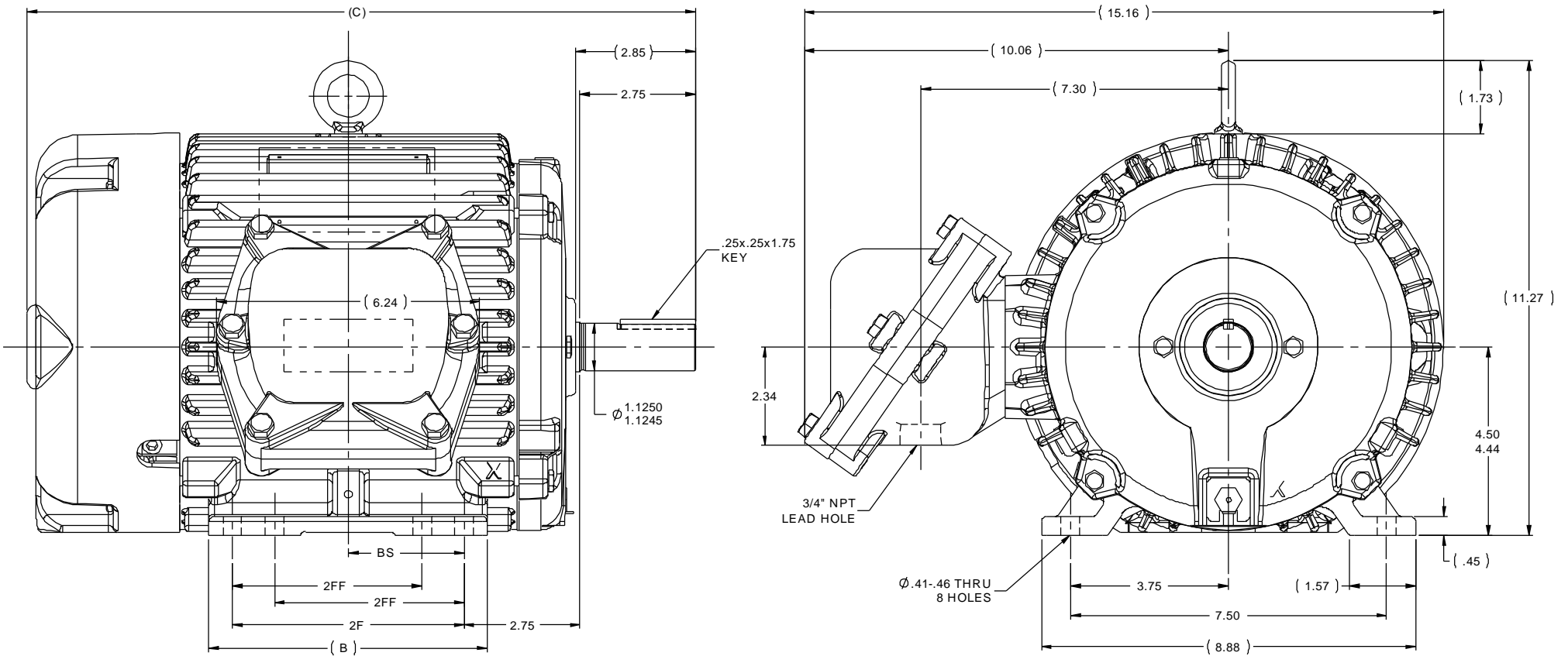

- NOTES:  
 1. NAMEPLATE TO BE READ FROM CONDUIT BOX SIDE OF MOTOR.  
 2. CONDUIT BOX CAN ROTATED IN 90° STEPS.  
 3. CONDUIT BOX CAN MOUNTED ON OPPOSITE SIDE BY REMOVING BRACKETS AND TURNING FRAME 180°. THIS MODIFICATION CAN BE PERFORMED ONLY BY THE ORIGINAL EQUIPMENT MANUFACTURER, OR BY A FACILITY THAT IS COVERED UNDER UNDERWRITERS LABORATORIES INC. CATEGORY PTKQ. TITLED "MOTORS AND GENERATORS REBUILT FOR USE IN HAZARDOUS LOCATIONS."

1000	184	17.87	8.61	7.50	5.50	3.75
800	182/184	15.87	6.61	5.50	4.50	2.75
DASH	FRAME	C	B	2F	2FF	BS

		TOLERANCES UNLESS SPECIFIED				DRAWN ST 8-25-2009	
		DEC	INCHES			CHK VV 8-25-2009	
		X	±.1	TITLE OUTLINE - EPFC		APPR	
		XX	±.03	180 FR.		SCALE 7:16	
		XXX	±.005	MOTL		REF 035660.00	
01	FRAME & BS DIM. 1000DSH WAS 182/184 & 2.75 RESP.	PVR 7/11/2012	AK	XXXX	±.0005	FMF	
NO	REVISION	BY & DATE	CHK	ANG	±7'30"	PREV	
THIS DRAWING IN DESIGN AND DETAIL IS OUR PROPERTY AND MUST NOT BE USED EXCEPT IN CONNECTION WITH OUR WORK. ALL RIGHTS OF DESIGN AND INVENTION ARE RESERVED. THIS IS AN ELECTRONICALLY GENERATED DOCUMENT - DO NOT SCALE THIS PRINT				RFP		CAD FILE 035660LE	SIZE B
				DIST	WA - NLV	DRAWING NO 035660LE	REV 01

THREE PHASE - SINGLE VOLTAGE  
MOTOR - CONDUIT BOX @ 'A'

TO REVERSE ROTATION:  
INTERCHANGE ANY TWO LINE  
LEAD CONNECTIONS

NOTE FOR FACTORY USE ONLY:  
TO SURGE TEST:  
FOR 3 LEAD COMMON CONNECT:  
CONNECT P1 TO T1 THEN P2 TO L1  
FOR 6 LEAD COMMON CONNECT:  
CONNECT P1 TO BOTH T1  
THEN P2 TO L1

3 THERMO - PROTECTORS  
CONNECTED IN SERIES.

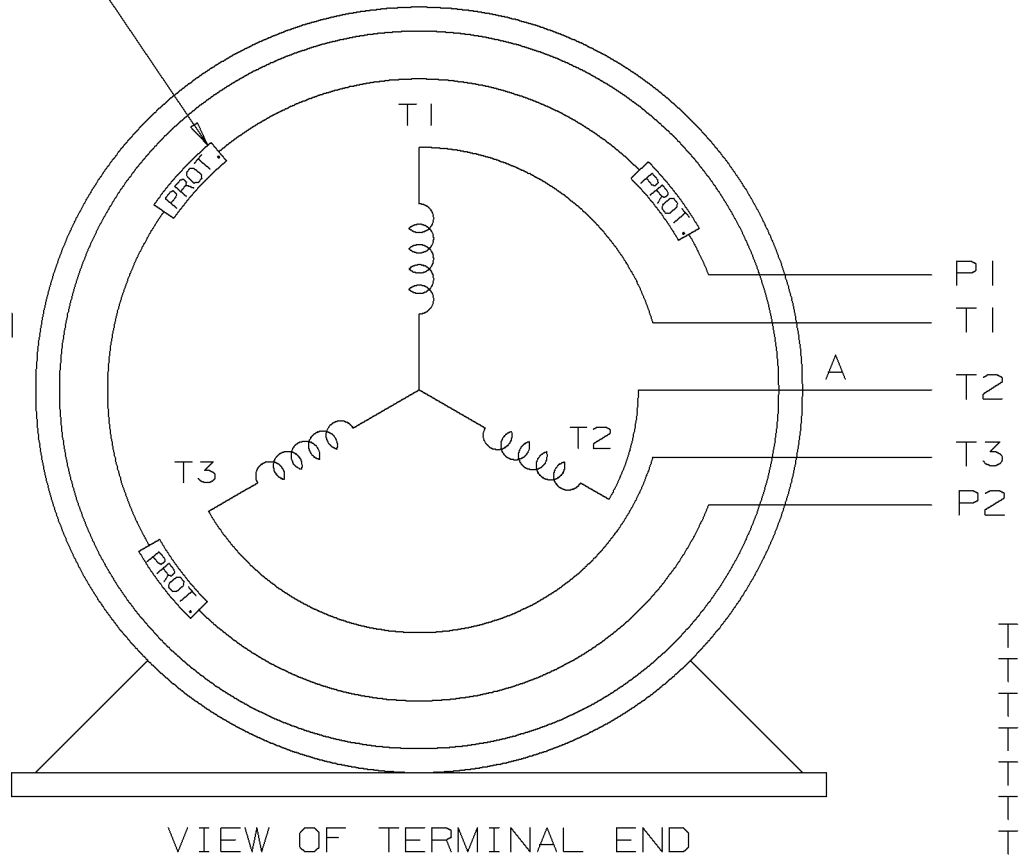

- T2BM
- T6AW
- T6AL
- T6Z
- T4EG
- T4BF
- T8A
- T6H
- T6A
- T4AX
- T4A
- T2A
- T2F

IF MOTOR HAS 12 LEADS

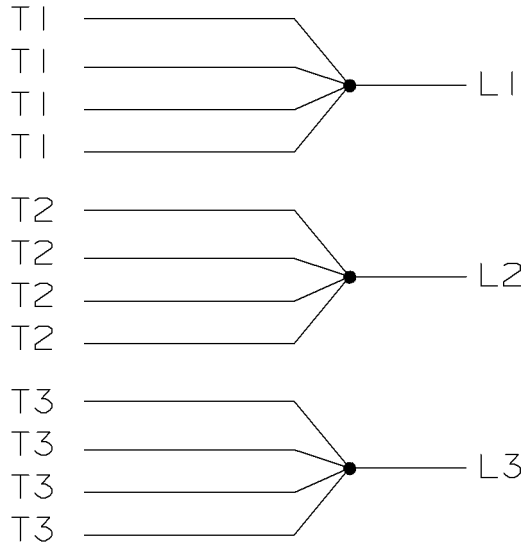

				✓ MAX. SURFACE ROUGHNESS UNLESS NOTED OTHERWISE	UNLESS OTHERWISE SPECIFIED DIMENSIONS ARE IN INCHES TOL. ON XX±      XXX±.005      XXXX±.0005      ANGLES±		
1 4	06-03-97	ADDED SURGE TESTER NOTE - FOR FACTORY USE ONLY                      CN 24255	MH	MATL SPEC	 <b>MARATHON</b> <b>ELECTRIC</b> WAUSAU, WISCONSIN 54401	DRAWN BY LZ	01-04-94
1 3	01-24-94	REDRAWN ON CADD - NO CHANGE	LZ	FINISH		CHKD BY ML	01-20-94
REV	DATE	CHANGE	NAME	PART NAME		APPD BY GK	01-20-94
				CONNECTION DIAGRAM			DRWG NO
				SINGLE VOLT - 3Ø MOTOR WITH PROTECTOR			A- EE7300T
SHOP BOOK		PURCHASED	DISTRIBUTION - WA - LB - WP - LM - YK		CADD FILE NO.	EE7300TX	

Data Sheet

Date: 5/24/2024  
 Customer: \_\_\_\_\_  
 Attention: \_\_\_\_\_  
 Submitted by: VESHNU G



182TTGCD6530

Submittal

Data @ 575 V

Motor Load Data

Load	0%	25%	50%	75%	100%	115%	125%	LR
Current (Amps)	1.84	1.92	2.24	2.72	3.2	3.6	3.8	25.6
Torque (ft-lb)	0.00	2.20	4.4	6.7	9.0	10.3	11.2	22.0
RPM	1800	1790	1782	1772	1762	1,758	1755	0
Efficiency (%)		79.5	86.5	88.5	89.5	89.5	88.5	
P.F. (%)	7.0	37.0	57.0	70.0	78.0	80.0	82.0	48.0

Motor Speed Data

	LR	Pull-Up	BD	Rated	Idle
Speed (RPM)	0	900	1675	1762	1800
Current (Amps)	25.6	22.4	14.4	3.2	1.84
Torque (ft-lb)	22.0	17.0	30.0	9.0	0.00

Information Block				
HP	3.0			
Sync. RPM	1800			
Frame	182			
Enclosure	EPFC			
Construction	TFC			
Voltage	575 V			
Frequency	60 Hz			
Design	B			
LR Code letter	K			
Service Factor	1			
Temp Rise @ FL	45 ° C			
Duty	CONT			
Ambient	50 ° C			
Elevation	3,300 feet			
Rotor/Shaft wk <sup>2</sup>	0.30 Lb-Ft <sup>2</sup>			
Ref Wdg	HA31124021 R1			
Sound Pressure @ 1M	62 dBA			
VFD Rating	CONSTANT 10:1			
Outline Dwg	035660-800			
Conn. Diag	A-EE7300T			
Additional Specifications:				
0				
0				
EQUIV CKT (OHMS / PHASE)				
R1	R2	X1	X2	Xm
3.6950	2.2170	8.4250	8.4250	184.7660

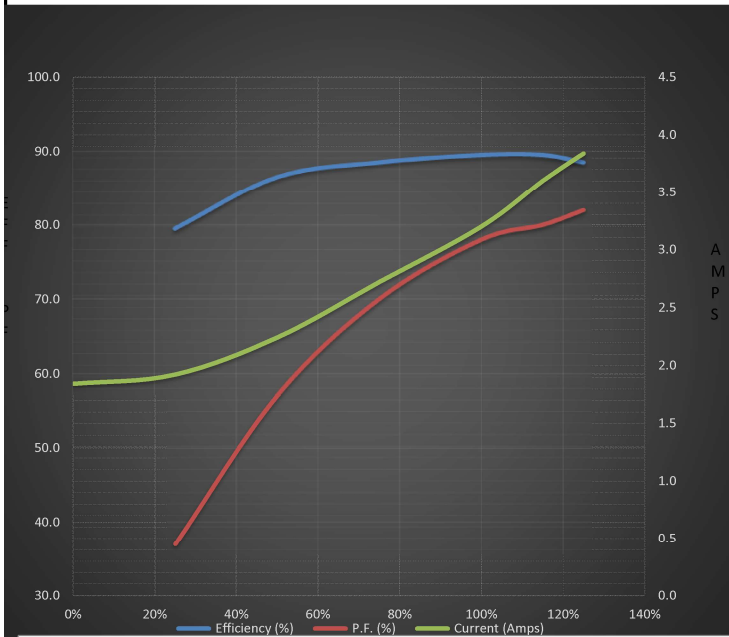

Speed - Torque Curve

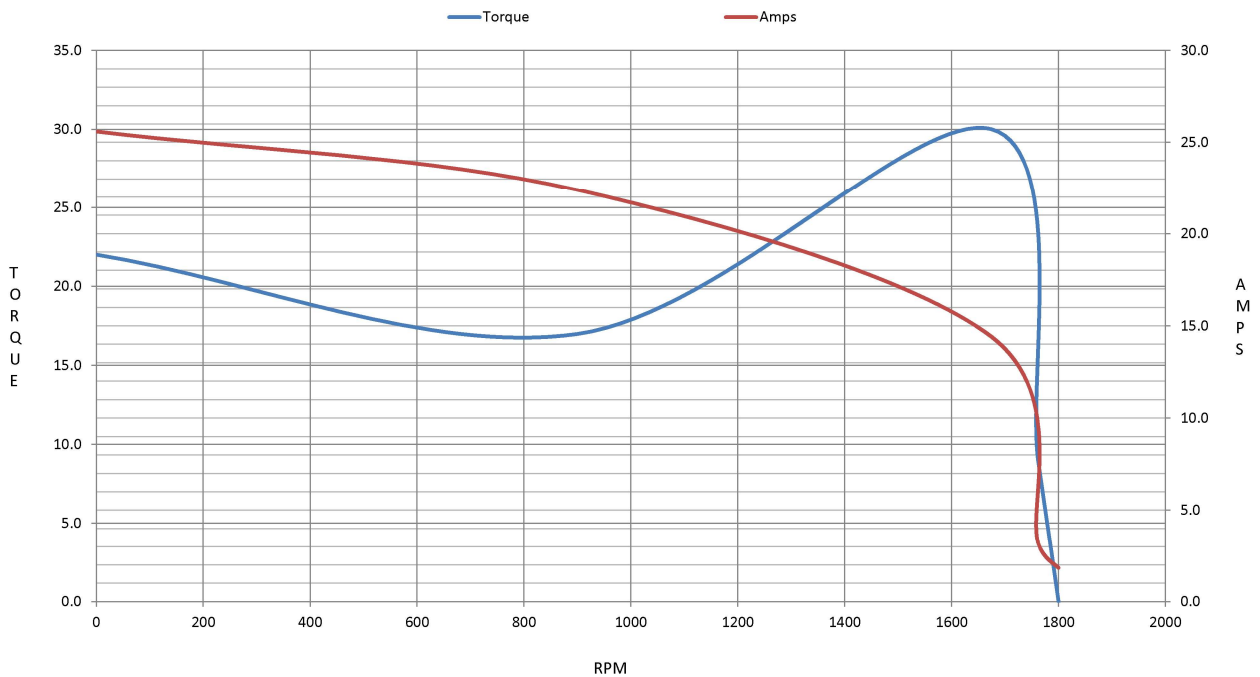

# CERTIFICATE OF COMPLIANCE

**Certificate Number** 20220217- E12044  
**Report Reference** E12044-20090313  
**Issue Date** 2022-FEBRUARY-17

**Issued to:** REGAL BELOIT AMERICA INC  
1946 W COOK RD  
FORT WAYNE IN 46818

Tradename: Marathon

**This certificate confirms that representative samples of**

MOTORS FOR USE IN HAZARDOUS LOCATIONS  
Electric motors for use in hazardous locations; Class I, Groups C and D; Class II, Groups F and G; Inclusive of Model Number 182TTGCD6530 (may have prefix and/or suffix characters).

Have been investigated by UL in accordance with the Standard(s) indicated on this Certificate.

**Standard(s) for Safety:** UL 674 - Electric Motors and Generators for Use in Division 1 Hazardous (Classified) Locations, CSA C22.2 No. 145, Electric Motors and Generators for Use in Hazardous (Classified) Locations

**Additional Information:** See the UL Online Certifications Directory at <https://iq.ulprospector.com> for additional information.

This *Certificate of Compliance* does not provide authorization to apply the UL Mark. Only the UL Follow-Up Services Procedure provides authorization to apply the UL Mark.

Only those products bearing the UL Mark should be considered as being UL Certified and covered under UL's Follow-Up Services.

Look for the UL Certification Mark on the product.

This is to certify that representative samples of the product as specified on this certificate were tested according to the current UL requirements.



Bruce Mahrenholz, Director North American Certification Program  
UL LLC

Any information and documentation involving UL Mark services are provided on behalf of UL LLC (UL) or any authorized licensee of UL. For questions, please contact a local UL Customer Service Representative at <http://ul.com/aboutul/locations/>

