

PRODUCT INFORMATION PACKET

marathon®
Motors

Model No: 182TCDW7318

Catalog No: Z406A

Close-Coupled Pump Motor, 3 HP, 1 Ph, 60 Hz, 115/230 V, 3600 RPM, 182JM Frame, DP



Regal and Marathon are trademarks of Regal Rexnord Corporation or one of its affiliated companies.

©2022 Regal Rexnord Corporation, All Rights Reserved. MC017097E

RegalRexnord

Nameplate Specifications

Output HP	3 Hp	Output KW	2.2 kW
Frequency	60 Hz	Voltage	115/230 V
Current	32.0/16.1 A	Speed	3500 rpm
Service Factor	1.15	Phase	1
Efficiency	75.5 %	Power Factor	80
Duty	Continuous	Insulation Class	F
Design Code	L	KVA Code	G
Frame	182JM	Enclosure	Drip Proof
Thermal Protection	No Protection	Ambient Temperature	40 °C
Drive End Bearing Size	6207	Opp Drive End Bearing Size	6205
UL	Recognized	CSA	Y
CE	Y	IP Code	22
Number of Speeds	1		

Technical Specifications

Electrical Type	Capacitor Start Induction Run	Starting Method	Across The Line
Poles	2	Rotation	Selective Counterclockwise
Resistance Main	.342 Ohms	Mounting	Rigid Base
Motor Orientation	Horizontal	Drive End Bearing	Ball
Opp Drive End Bearing	Ball	Frame Material	Rolled Steel
Shaft Type	JM	Overall Length	15.32 in
Frame Length	9.50 in	Shaft Diameter	0.875 in
Shaft Extension	4.25 in	Assembly/Box Mounting	F1 ONLY
Connection Drawing	005062.01ME	Outline Drawing	035557-950

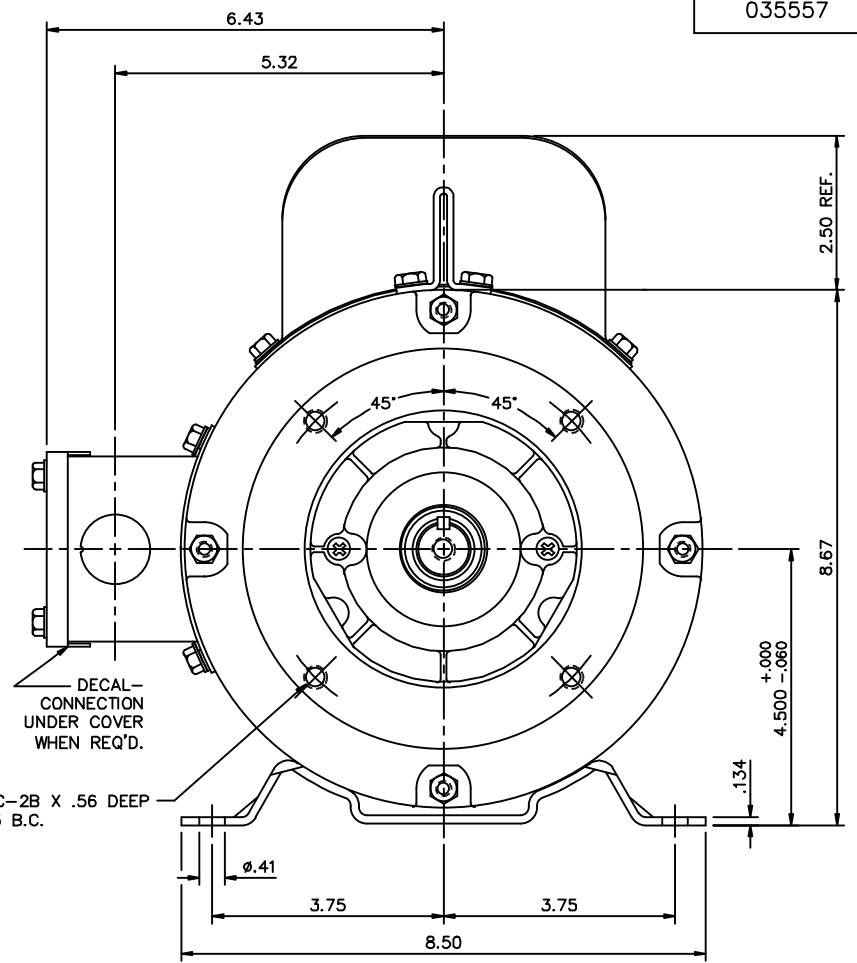
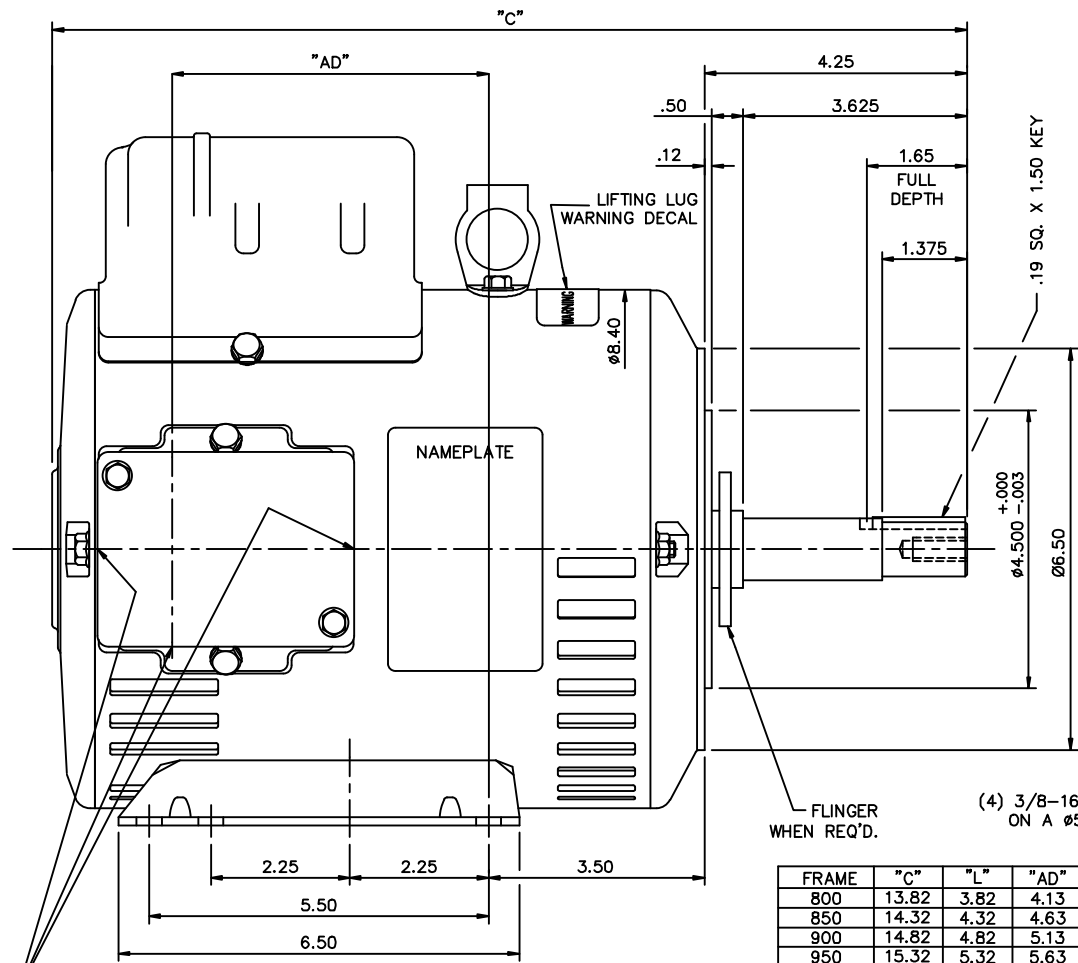

(4) 3/8-16 UNC-2B X .56 DEEP ON A Ø5.875 B.C.

FRAME	"C"	"L"	"AD"
800	13.82	3.82	4.13
850	14.32	4.32	4.63
900	14.82	4.82	5.13
950	15.32	5.32	5.63
1000	15.82	5.82	6.13
1050	16.32	6.32	6.63
1100	16.82	6.82	7.13
1150	17.32	7.32	7.63
1200	17.82	7.82	8.13

Ø1.13 KNOCKOUTS (3) REQUIRED

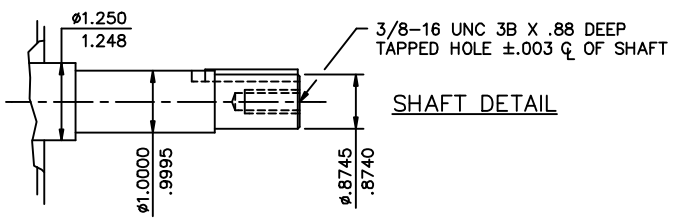

GASKETS THROUGHOUT
 MAXIMUM FACE RUNOUT TO BE .004 T.I.R.
 MAXIMUM PILOT ECCENTRICITY TO BE .004 T.I.R.
 PERMISSIBLE SHAFT RUNOUT TO BE .002 T.I.R.

				TOLERANCES UNLESS SPECIFIED		MARATHON ELECTRIC	DRAWN VV 08/30/07				
				DEC.	INCHES		CHK	YS 08/30/07			
				.X	±.1	TITLE	SCALE	1-2			
				.XX	±.03		OUTLINE- 180T FRAME	REF	035472		
02	ADDED FLINGER WHEN REQ'D ISAAC 12-2578	GWS	6/11/12	.XXX	±.005	DRIP PROOF- RIGID	REF	035472			
01	SHAFT HOLE WAS 3A x .56 DEEP, WARNING NOTE ADDED	JD	05/26/11	.XXXX	±.0005	MAT'L	FMF	184TCDW7047			
NO.	REVISION	BY & DATE	CHK	ANG	FINISH	PREV					
THIS DRAWING IN DESIGN AND DETAIL IS OUR PROPERTY AND MUST NOT BE USED EXCEPT IN CONNECTION WITH OUR WORK ALL RIGHTS OF DESIGN AND INVENTION ARE RESERVED THIS IS AN ELECTRONICALLY GENERATED DOCUMENT - DO NOT SCALE THIS PRINT						RFP	CAD FILE	035557	SIZE	DRAWING NO.	REV.
						DIST			B	035557	02

VIEW FROM OUTSIDE OF MOTOR AT SWITCH END.

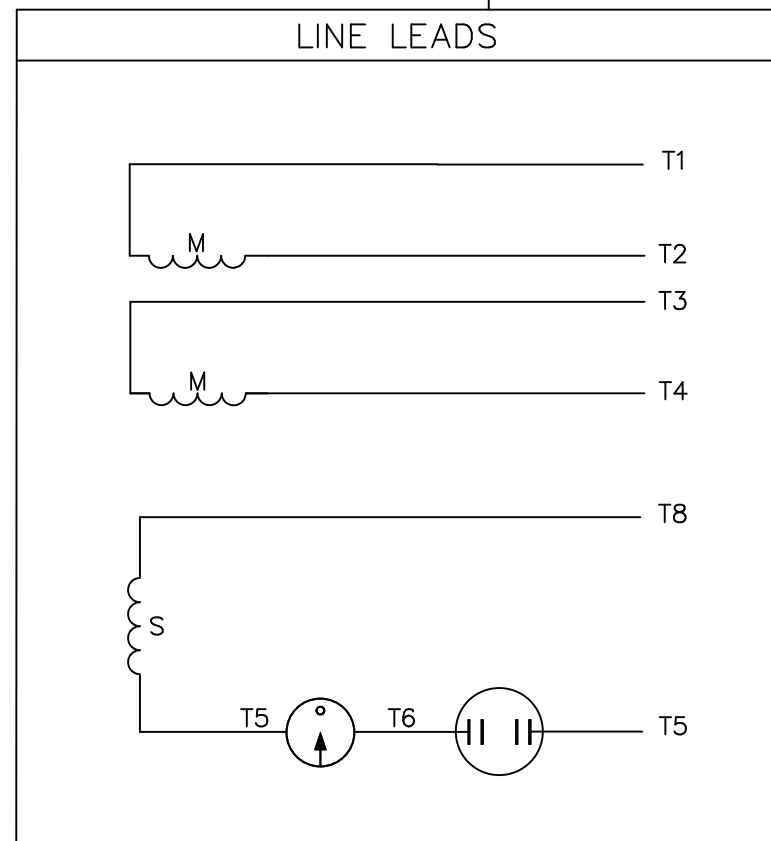
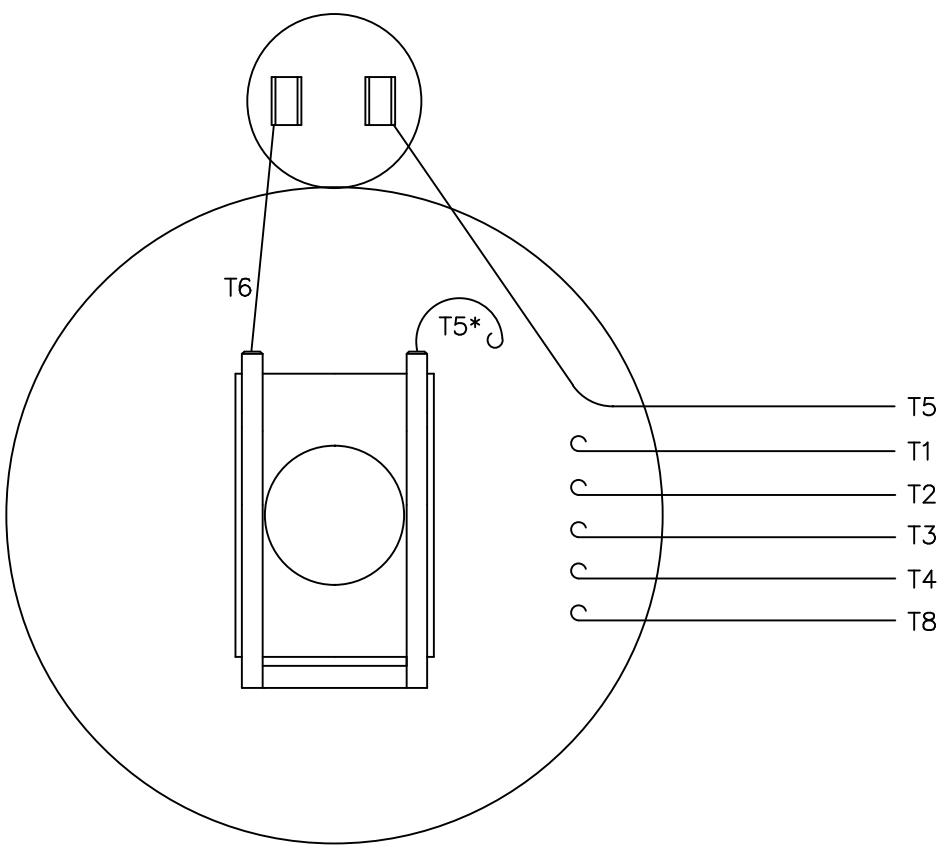

	ROTATION FACING LEAD END	L1	L2	JOIN
HIGH VOLT	C.C.W.	T1	T4 T5	T2, T3 T8
	C.W.	T1	T4 T8	T2, T3 T5
LOW VOLT	C.C.W.	T1, T3 T8	T2, T4 T5	-----
	C.W.	T1, T3 T5	T2, T4 T8	-----

* THIS LEAD MAY BE WHITE

				TOLERANCES UNLESS SPECIFIED			DRAWN RDW 6/30/03		
				DEC.	INCHES		CHK		
				.X	±.1		APPD		
				.XX	±.01		SCALE 1=1		
				.XXX	±.005		REF		
				.XXXX	±.0005	MAT'L. DECAL - 004012			
NO.	REVISION	BY & DATE	CHK	ANG	±1/2'	FINISH	FMF 139043	PREV	
THIS DRAWING IN DESIGN AND DETAIL IS OUR PROPERTY AND MUST NOT BE USED EXCEPT IN CONNECTION WITH OUR WORK ALL RIGHTS OF DESIGN AND INVENTION ARE RESERVED THIS IS AN ELECTRONICALLY GENERATED DOCUMENT - DO NOT SCALE THIS PRINT				RFP		CAD FILE 00506201ME	SIZE A	DRAWING NO. 005062-01ME	REV.
				DIST					



MARATHON ELECTRIC CORPORATION
TYPICAL PERFORMANCE CURVE for AC MOTOR

Customer

Curve at

230 Volts
60 HZ
3 HP

HP 3.00

PHASE 1

Model No 182TCDW7318

VOLTS 115/230

Catalog No Z406A

HZ 60

RPM 3500

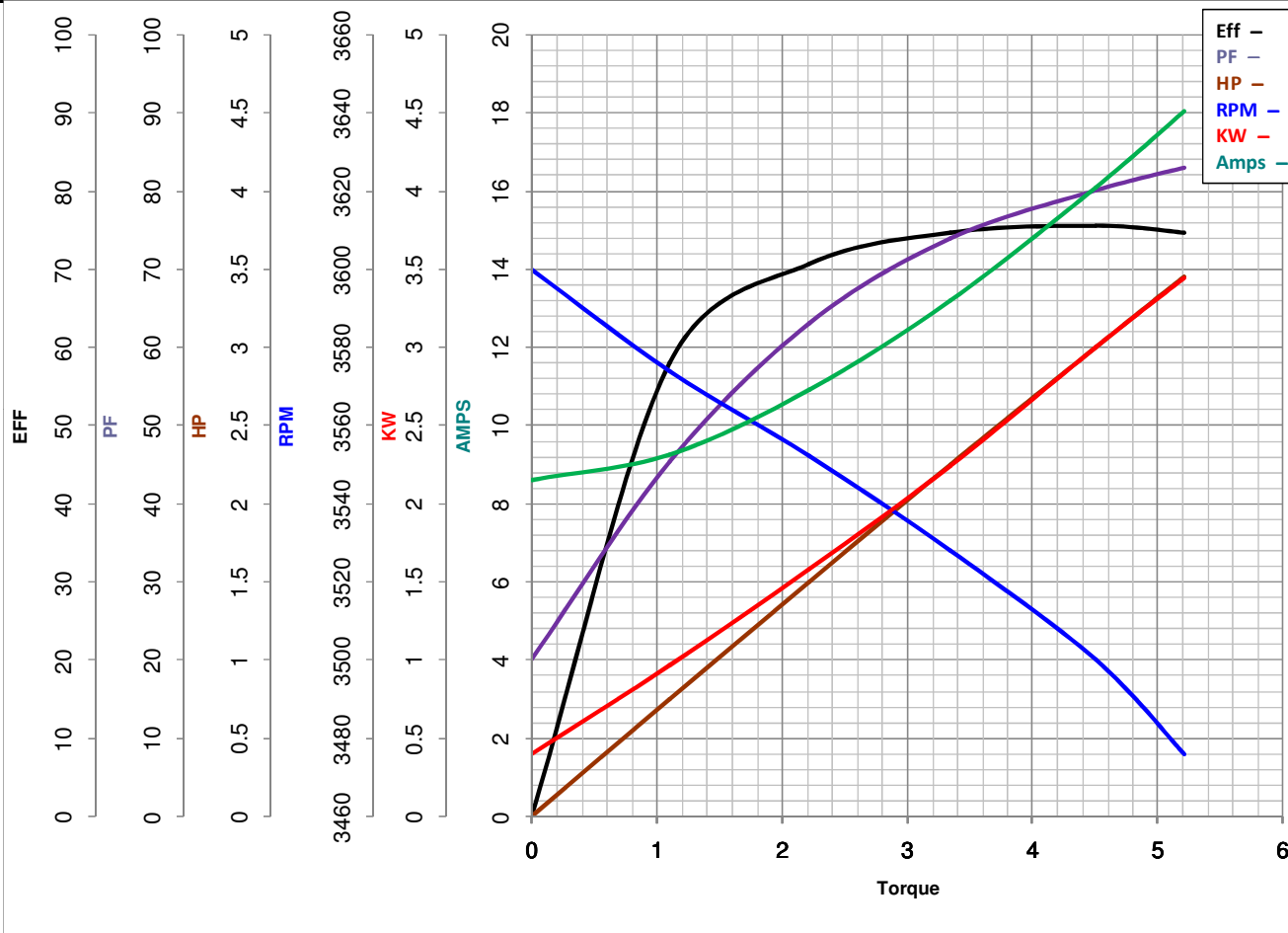

Torque in Lb.Ft

FL TORQUE 4.5 Lb.Ft
BD TORQUE 10.5 Lb.Ft
LR TORQUE 7.3 Lb.Ft

FL AMPS 32/16.1
PU TORQUE 6.9 Lb.Ft
LR AMPS 79.9

WINDING C8219-

Date 3/7/2019

EC Declaration of Conformity

The undersigned representing
the manufacturer:

Regal Beloit America
100 East Randolph St.
Wausau, WI 54401

and the authorized representative
established within the Community:

Marathon Electric UK
6F Thistleton Road Ind. Estate
Market Overton
Oakham, Rutland LE15 7PP UK

are committed to providing customers with products that comply with applicable regulations and international protocols to which they are subject, including the requirements of the European Parliament Directive on the Harmonization of the laws relating to electrical equipment designed for use within certain voltage limits (2014/35/EU).

Regal Beloit America declares that the following product(s), to which this declaration relates, are in conformity with the relevant sections of the EC standards listed below.

This statement supersedes any statements previously issued pertaining to the product(s) listed below and is subject to change without notice.

Model No : 182TCDW7318

(Model No. may contain prefix and/or suffix characters)

Catalog No : Z406A

Rework No : N/A

Directives :

Low Voltage Directive 2014/35/EU

Harmonized Standards Used :

EN 60034-1: 2010 (IEC 60034-1: 2010)

EN 60034-5: 2001/A1:2007 (IEC 60034-5: 2000/A1:2006)

Authorized Representative:



Michael A. Logsdon
Vice President, Technology

Authorized Representative in the Community:



Julian Clark
Marketing Engineer

Created on 09/01/2022

CE 22