

PRODUCT INFORMATION PACKET



Model No: 171829.60

Catalog No: 171829.60

Severe Duty Motor, 30 & 25 HP, 3 Ph, 60 & 50 Hz, 230/460 & 190/380 V, 1800 & 1500 RPM, 286TC Frame,
TEFC

Regal and Leeson are trademarks of Regal Rexnord Corporation or one of its affiliated companies.

©2023 Regal Rexnord Corporation, All Rights Reserved. MC017097E





Nameplate Specifications

Phase	3	Output HP	30 & 25 Hp
Output KW	22.4 & 18.7 kW	Voltage	230/460 & 190/380 V
Speed	1780 & 1480 rpm	Service Factor	1.15 & 1.15
Frame	286TC	Enclosure	Totally Enclosed Fan Cooled
Thermal Protection	No Protection	Efficiency	94.1 & 93 %
Ambient Temperature	40 °C	Frequency	60 & 50 Hz
Current	70/35 & 71/35.5 A	Power Factor	85.6
Duty	Continuous	Insulation Class	F
Design Code	A	KVA Code	H
Drive End Bearing Size	6311	Opp Drive End Bearing Size	6309
UL	Recognized	CSA	Y
CE	Y	IP Code	55
Number of Speeds	1		

Technical Specifications

Electrical Type	Squirrel Cage Inverter Rated	Starting Method	Wye Start Delta Run Or Inverter
Poles	4	Rotation	Reversible
Resistance Main	.052 Ohms	Mounting	Rigid Base
Motor Orientation	Horizontal	Drive End Bearing	Ball
Opp Drive End Bearing	Ball	Frame Material	Cast Iron
Shaft Type	T	Overall Length	27.84 in
Shaft Diameter	1.875 in	Shaft Extension	4.87 in
Assembly/Box Mounting	F1/F2 CAPABLE		
Outline Drawing	SS622045LE-N286TC-4	Connection Drawing	004172.01

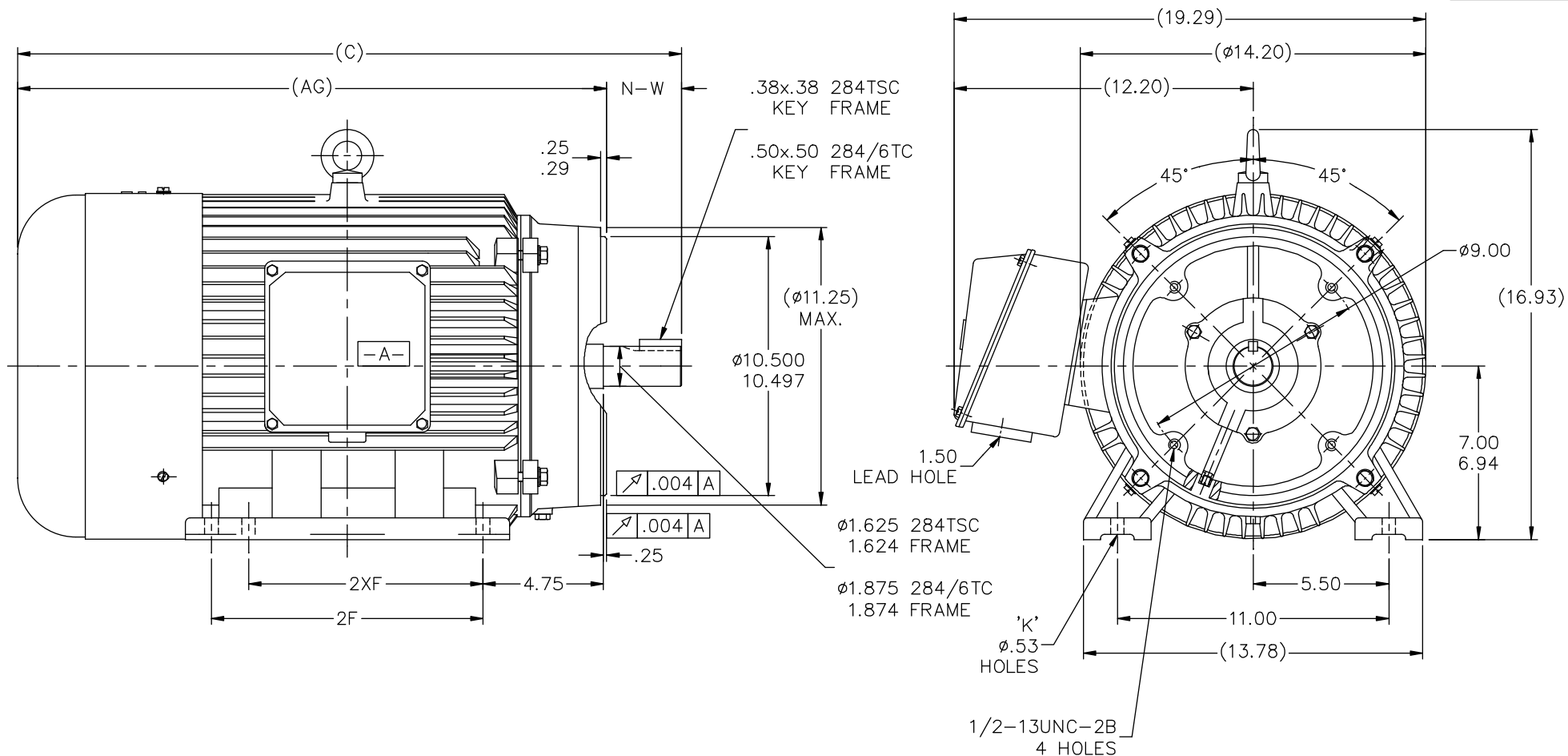

NOT DRAWN TO SCALE

DASH	FRAME	C	AG	B	2F	2XF	K	N-W
---	N286TC-2	27.84	23.22	---	11.00	9.50	6	4.62
---	N286TSC-2	26.47	23.22	---	11.00	9.50	6	3.25
---	N284TC-2	26.26	21.64	---	9.50	---	4	4.62
---	N284TSC-2	24.88	21.64	---	9.50	---	4	3.25
---	N284TC-4	26.26	21.64	---	9.50	---	4	4.62
---	N286TC-4	27.84	23.22	---	11.00	9.50	6	4.62

NO.	REVISION	BY & DATE	TOLERANCES UNLESS SPECIFIED		FINISH	TITLE	DRAWN MSG 08-11-2005		
			DEC.	INCHES					
			.X	±.1		LEESON ELECTRIC MOTORS GEARMOTORS AND DRIVES TITLE OUTLINE 284TSC, 284/286TC FR. - C'FACE MAT'L. RFP CAD FILE ss622045le DIST LB	CHK ML 08-12-2005		
			.XX	±.03			APPD LMC 08-24-2005		
			.XXX	±.005			SCALE 1=2		
			.XXXX	±.0005			REF		
				±7'30"			FMF		
							PREV 250014140-60		
THIS DRAWING IN DESIGN AND DETAIL IS OUR PROPERTY AND MUST NOT BE USED EXCEPT IN CONNECTION WITH OUR WORK ALL RIGHTS OF DESIGN AND INVENTION ARE RESERVED THIS IS AN ELECTRONICALLY GENERATED DOCUMENT - DO NOT SCALE THIS PRINT			RFP			SIZE B	DRAWING NO. SS622045LE	PAGE OF	REV.

WYE - DELTA STARTING USEABLE ON 2,4 AND 6 POLE MOTORS.

LOW VOLTAGE CONNECTION

HIGH VOLTAGE CONNECTION

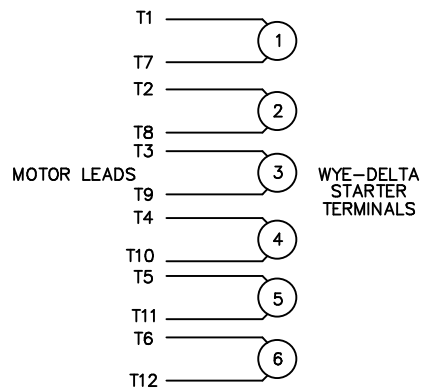

REFER TO THE WYE-DELTA STARTER CONNECTION INSTRUCTIONS FOR PROPER CONNECTION OF POWER LINES TO STARTER.

PART WINDING START USABLE ON 4 & 6 POLE MOTORS
LOW VOLTAGE CONNECTION ONLY

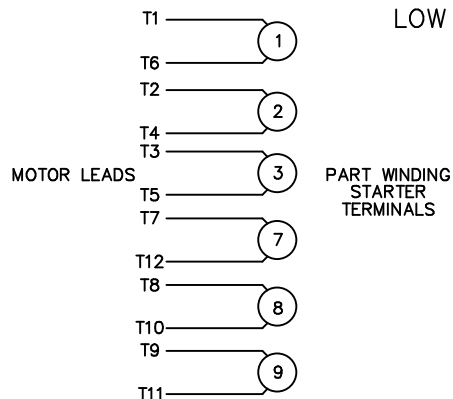

REFER TO THE PART WINDING STARTER INSTRUCTIONS FOR PROPER CONNECTION OF POWER LINES TO STARTER.

REFER TO THE CUTLER - HAMMER OR EQUIV. FOR PROPER SELECTION OF OVERLOAD HEATER COILS.



ACROSS THE LINE START & RUN				
	LINE 1	LINE 2	LINE 3	JOIN & INSULATE SEPARATELY
HIGH VOLT	T1, T12	T2, T10	T3, T11	(T4, T7) (T5, T8) (T6, T9)
LOW VOLT	T1, T6 T7, T12	T2, T4 T8, T10	T3, T5 T9, T11	

				TOLERANCES UNLESS SPECIFIED		ELECTRIC MOTORS GEARMOTORS AND DRIVES	DRAWN WLW 09/08/77		
				DEC.	INCHES		CHK RPB 09/12/77		
				.X	±.1		APPD JCW 09/12/77		
03	REV'D LOW VOLTAGE CONN. LEADS PER ELEC.	BJB 06/07/00	.XX	±.01	TITLE	DELTA - WYE CONNECTION DIAGRAM	SCALE	1=1	
02	ADDED T-STAT. NOTES PER ELECTRICAL	KMM 06/02/98	.XXX	±.005			REF		
01	REDRAWN TO CAD	DBT 06/02/97	.XXXX	±.0005	MAT'L.		FMF		
NO.	REVISION	BY & DATE	CHK	ANG	±1/2"	FINISH	PREV		
THIS DRAWING IN DESIGN AND DETAIL IS OUR PROPERTY AND MUST NOT BE USED EXCEPT IN CONNECTION WITH OUR WORK ALL RIGHTS OF DESIGN AND INVENTION ARE RESERVED THIS IS AN ELECTRONICALLY GENERATED DOCUMENT - DO NOT SCALE THIS PRINT				RFP	CAD FILE	00417201	SIZE	DRAWING NO.	REV.
				DIST			A	004172-01	03