

PRODUCT INFORMATION PACKET

marathon[®]
Motors

Model No: 529854C-Y
Catalog No: 529854C-Y
D-529854C-Y BRKT MCH -740 FRONT (RTD) -CARTRIDGE BRG -LDG SPRING

Regal and Marathon are trademarks of Regal Rexnord Corporation or one of its affiliated companies.
©2025 Regal Rexnord Corporation, All Rights Reserved. MC017097E

RegalRexnord

Nameplate Specifications

Technical Specifications

This is an uncontrolled document once printed or downloaded and is subject to change without notice. Date Created:04/05/2025

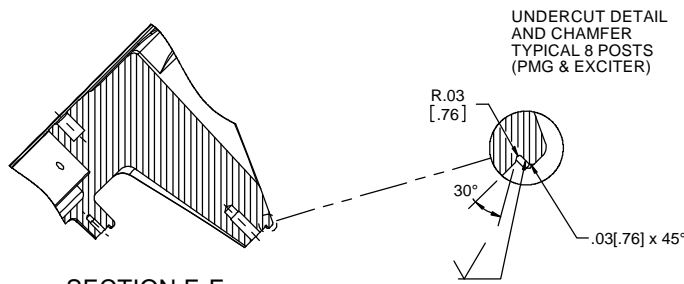

SECTION E-E

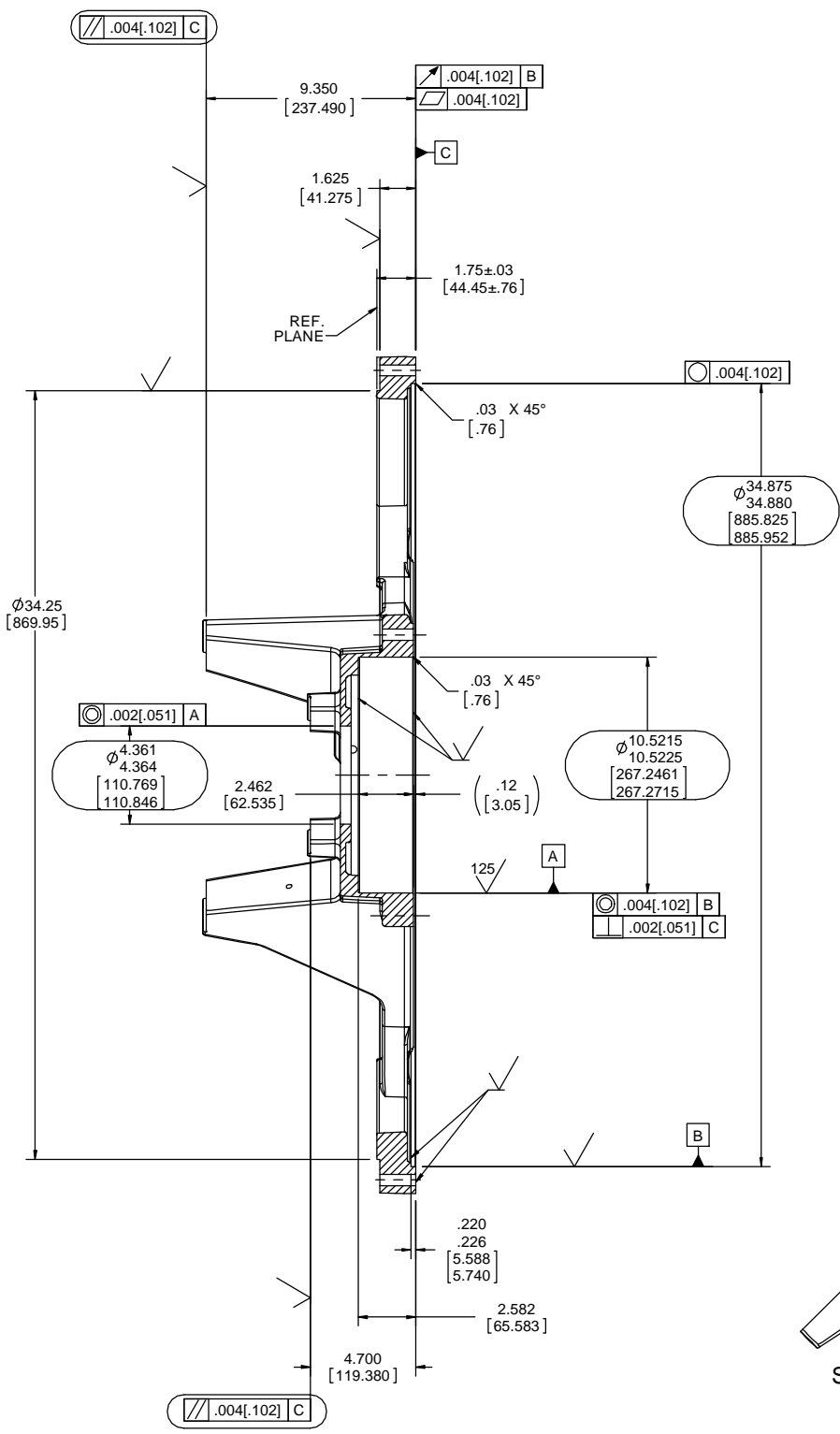
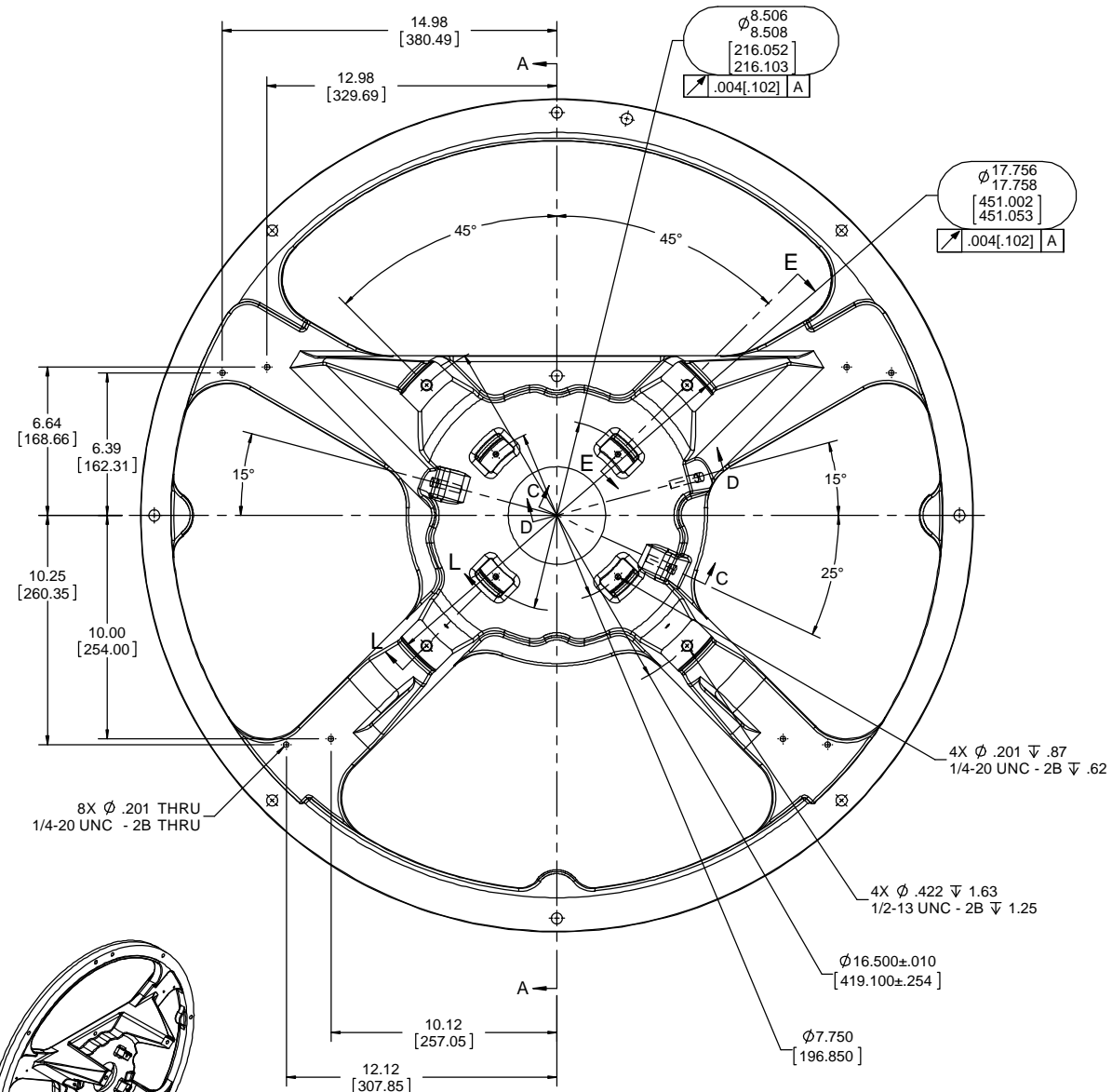
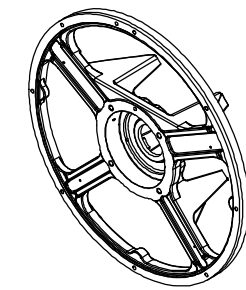

SECTION A-A

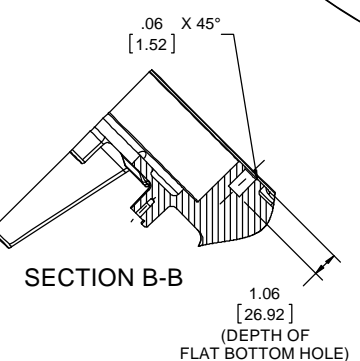
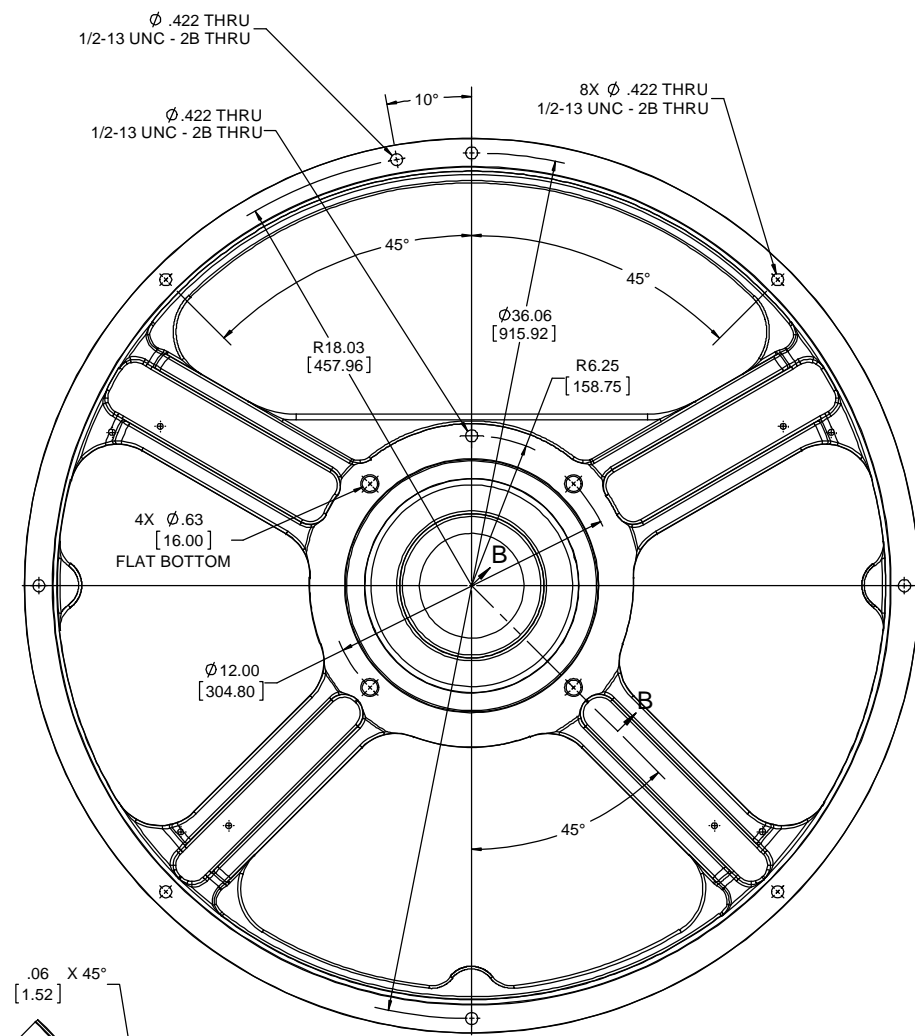

SECTION B-B

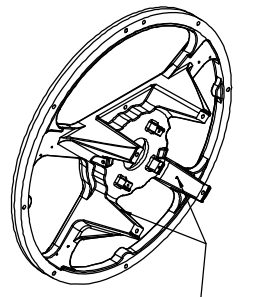

(2X 1/4-20 TAPPED HOLES - REFER TO SECTION L-L)

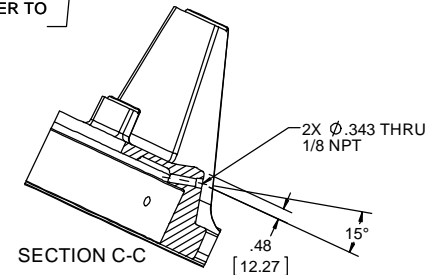

SECTION C-C

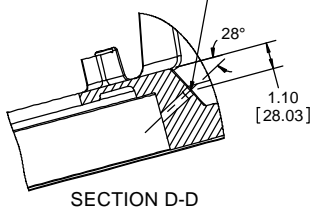

SECTION D-D

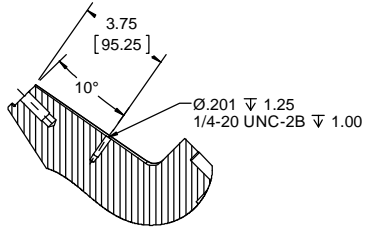

SECTION L-L
2PL (90° APART)

ANNOTATIONS IN INDICATE CRITICAL TO QUALITY (CTQ) DIMENSIONS

NOTE: MATERIAL MEETS ASTM MATERIAL HARDNESS

DRAWING REVISION E	REVISION BY TM	DATE 06-30-2017	TOLERANCES UNLESS OTHERWISE SPECIFIED: DEC. INCH mm ANGLE .X ±0.1 [2.5] 27 30° .XX ±0.02 [0.51] .XXX ±0.005 [0.127] XXX ±0.005 [0.0127]	DRAWN BY TJW	DATE 03-12-2012	APPROVED BY JER	DESCRIPTION END FRAME-MACHINED
ECO-0118329	APPROVED BY CDP	DATE 06-30-2017	REMOVE BURRS & BREAK SHARP EDGES: .003/.015 [0.076/.381] X 45° CORNER FILLETS: R.02 [51] MACHINED SURFACES: 200 INCR/1.0 mm SHOWN IN [BRACKETS]	DATE 03-12-2012	REFERENCE 529854B	MATERIAL CASTING 529854	PROCESS/FINISH
<small>PROPRIETARY AND CONFIDENTIAL INFORMATION - THIS DOCUMENT IS THE PROPERTY OF REGAL BELLOIT AMERICA, INC. CONSUMER AND CONTAINS OWNERS PROPRIETARY INFORMATION. ANY PERSON, CORPORATION OR OTHER FIRM RECEIVING IT IS DEEMED, BY RECEIVING IT, TO AGREE THAT IT, AND/OR ANY PART OF IT, SHALL NOT BE DISCLOSED TO ANY PERSON, CORPORATION OR OTHER ENTITY, DUPLICATED, AND/OR USED, EXCEPT AS EXPRESSLY APPROVED IN WRITING IN ADVANCE BY OWNER. THIS DOCUMENT SHALL BE RETURNED TO OWNER UPON REQUEST. IT MAY BE SUBJECT TO CERTAIN RESTRICTIONS UNDER APPLICABLE EXPORT CONTROL LAWS AND REGULATIONS.</small>			THIRD ANGLE PROJECTION	SIZE D	DRAWING NUMBER 529854C	SHEET 1 OF 1	